

ICD-08E35

POPULAR COMMUNICATIONS

DECEMBER 1982 \$1.75

Secrets of Radio Propaganda



**Stretch Cordless Phone Range • New Year's Eve
DX'ing • Full Details: The San Francisco PD Network
• Tune in on Spy Stations • POP'COMM Scans
Pinkerton • Crisis Monitoring • Fade Out Fading
With Diversity • Ten Ways To Get More Out of Scanning**



Let's get personal...

try out the in-stock selection of Heath/Zenith microcomputers, peripherals, accessories and software.

Now available at your nearby Heathkit Electronic Center, or through the Heathkit mail order catalog.

You get more with a Heath/Zenith personal microcomputer system! We offer:

1. Proven high-performance hardware: Thousands of our microcomputers prove themselves daily, in the field.

2. Vast software library: Three operating systems (including CP/M), languages, word processors, an electronic spreadsheet, versatile utilities and the 500-program Heath Users' Group software library.

3. Self-instruction courses: Evaluation and programming courses from Heathkit/Zenith Educational Systems.

4. Service support: Before and after the sale - consultation by phone, carry-in service by trained technicians.

Test run one of our microcomputers at any of the more than 60 convenient Heathkit Electronic Centers in the U.S.

Heathkit[®] ELECTRONIC CENTERS*

See the white pages of your telephone book for store locations and telephone numbers.

*Units of Veritechnology Electronics Corporation in the U.S.

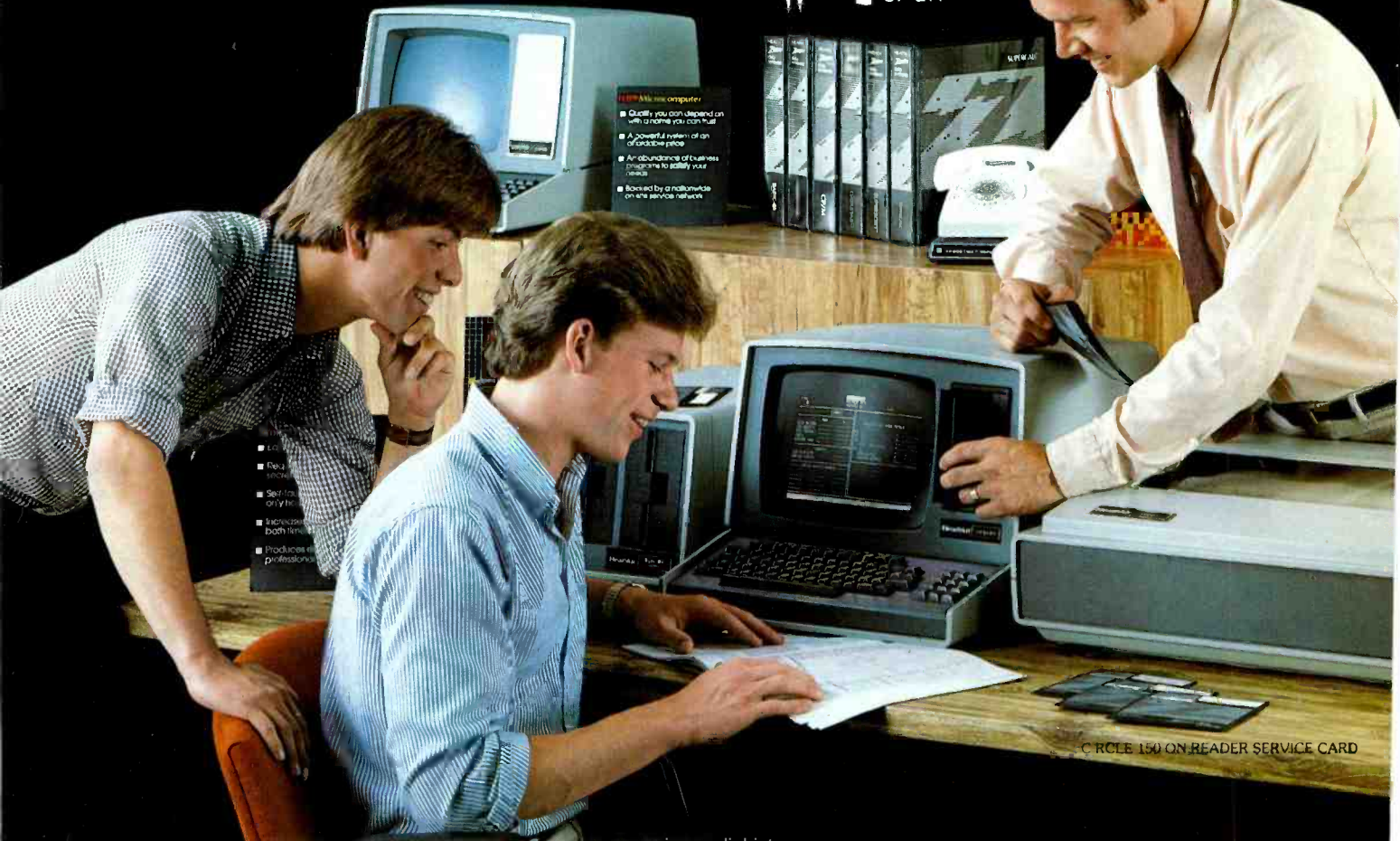

Circle 150 on Reader Service Card



INTRODUCING THE LATEST HEIR TO 59 YEARS OF GERMAN ENGINEERING.

While the fine lines and sculpted features of most sport bikes spring from the drawing tables of stylists, those of the BMW R65LS had a different birthplace.

The drafting tables of German engineers.

As a result, they are the recipients of the same pragmatic consideration and evolutionary refinement as the legendary engine that powers this 650cc machine.

The shapely sport fairing, for example, provides much more than cosmetic appeal. It helps reduce front-wheel lift by over 30%.

The LS handlebars are low, compact, and help to provide a seating position that "is sporting in a way that Japanese bikes, even with red paint, have not discovered" (Cycle World). (High bars are also available.)

The bike's slender tail,

artful as it too appears, was created in one of the most aesthetically indifferent environments known to man: the massive BMW wind tunnel in Ismaning, Germany.

Even the wheels of the LS possess a beauty that goes far deeper than their gleaming enamel. Each rim section is made of a highly rigid aluminum alloy; each hub and spoke assembly is separately cast from a far more elastic aluminum alloy to provide added flexibility. And then everything—hubs, spokes and rims—is cast as

a single unit. Culminating in an exceedingly resilient "composite" wheel that not only helps

increase handling prowess but decreases unsprung weight.

In the end, the BMW R65LS is one sports bike whose graceful lines do not serve as camouflage for weak engineering. For it is a machine as adept at slicing through the wind and rounding corners as it is at turning heads.

Its price? A lofty \$3,790*.

But as a motorcycle columnist of AutoWeek observed, "a bad motorcycle is worthless; a good motorcycle is worth whatever it costs... By that standard, the R65LS is a bargain."

*Manufacturer's suggested retail price. \$3,790. Actual price will depend upon dealer. Price excludes state and local taxes, dealer prep, destination and handling charges. © 1982 BMW of North America, Inc. The BMW trademark and logo are registered trademarks of Bayerische Motoren Werke, A.G.

THE LEGENDARY MOTORCYCLES OF GERMANY.



Moto-trak



Your key to ALL the satellites, ALL the programming, right from the comfort of your easy chair.

Satellite television offers so much to explore. Why settle for the one-satellite limitation of fixed dishes, or endless cranking at the dish in all kinds of weather? Enjoy all the convenience KLM's Moto-trak system has to offer . . .

- 12 automatic satellite selections at the twist of a dial
- Fully independent Azimuth and Elevation control, to search or optimize
- Spot LED "travel" indicators
- Constant LED Azimuth/Elevation readout
- Polarity Control, for all channels, horizontal and vertical
- 12' solid aluminum dish or 16' screened dish for a perfect picture

And, enjoy the reliability of a motorized mount that's precision engineered from the ground up. Not an afterthought or a flimsy add-on, KLM's Moto-trak uses industrial quality reduction motors, gear, and screw drives, state-of-the-art motor control electronics.

Best of all, the Moto-trak system is a perfect match for KLM's reliable SKY EYE II and new SR-3 Satellite Receivers. Complete systems are available NOW. Once again, more of the performance, features, convenience, and reliability you've come to expect from KLM.

KLM
P.O. Box 816, Morgan Hill, CA 95037
(408)779-7363

CIRCLE 27 ON READER SERVICE CARD

Send for KLM's
SITE SURVEY KIT
AZ-EL Tester, Manual,
Sat-Coordinates \$29.95

SR-3

(The one you've been waiting for!)



The SR-3 Satellite Receiver . . . once again, more of the performance, features, and convenience you've come to expect from KLM. Handsomely styled cabinet outside, state-of-the-art single conversion circuitry inside. Install the SR-3 up to 1000 feet from the dish; a single 50 ohm feedline makes it clean and easy. Select KLM's separate remote downconverter or the revolutionary "Ampliverter" that combines LNA and downconverter in one very compact package. And, enjoy these easy-to-look-at/easy-to-use features:

- Rapid "SCAN" for easy satellite tracking
- LED signal strength readout
- Positive detent channel tuning plus fine tune
- Full audio tuning/stereo version available
- Video inversion

The SR-3 with remote downconverter or Ampliverter is available NOW, just like KLM's new motorized dish systems with remote "Moto-Trak" control. More of the best from KLM.

KLM
P.O. Box 816, Morgan Hill, CA 95037
(408) 779-7363

CIRCLE 35 ON READER SERVICE CARD

Why use other computer media when you could be using MEMOREX high quality error free media?

Free Memorex Mini-Disc Offer - Get free discs!

You'll save money when you buy Memorex, because every carton of 10 Memorex 5 1/4 inch mini-discs sold by Communications Electronics has a coupon good for a free Memorex mini-disc. For every case of 100 Memorex mini-discs you buy from CE, you'll get 10 free Memorex mini-discs, directly from Memorex. The more you order, the more you save. Offer expires December 31, 1982. All Memorex flexible discs sold by CE are of the highest quality, certified 100% error free and backed by a full one year factory warranty.

Flexible Disc Quantity Discounts Available

Memorex Flexible Discs are packed 10 discs to a carton and 10 cartons to a case. Please order only in increments of 100 units for quantity 100 pricing. We are also willing to accommodate your smaller orders. Quantities less than 100 units are available in increments of 10 units at a 10% surcharge. **Quantity discounts** are also available. Order 500 or more discs at the same time and deduct 1%; 1,000 or more saves you 2%; 2,000 or more saves you 3%; 5,000 or more saves you 4%; 10,000 or more saves you 5%; 25,000 or more saves you 6%; 50,000 or more saves you 7% and 100,000 or more discs earns you an 8% discount off our super low quantity 100 price. Almost all Memorex Flexible Discs are immediately available from CE. Our warehouse facilities are equipped to help us get you the quality product you need, when you need it. If you need further assistance to find the flexible disc that's right for you, call the Memorex flexible disc compatibility hotline. Dial toll-free 800-538-8080 and ask for the *flexible disc hotline* extension 0997. In California dial 800-672-3525 extension 0997. Outside the U.S.A. dial 408-987-0997 between 9 AM to 4 PM Pacific Time.

SAVE ON MEMOREX FLEXIBLE DISCS

Product Description	Part #	CE quant. 100 price per disc (\$)
8" SSSD IBM Compatible (128 B/S, 26 Sectors)	3062	2.09
8" SSSD Shugart Compatible, 32 Hard Sector	3015	2.09
8" SSSD CPT 8000 Compatible, Soft Sector	3045	2.99
8" SSSD IBM Compatible (128 B/S, 26 Sectors)	3090	2.74
8" DSDD Soft Sector (Unformatted)	3102	3.34
8" DSDD Soft Sector (128 B/S, 26 Sectors)	3115	3.34
8" DSDD Soft Sector (256 B/S, 26 Sectors)	3103	3.34
8" DSDD Soft Sector (512 B/S, 15 Sectors)	3114	3.34
8" DSDD Soft Sector (1024 B/S, 8 Sectors)	3104	3.34
5 1/4" SSSD Soft Sector w/Hub Ring	3481	2.34
5 1/4" SSSD 10 Hard Sector w/Hub Ring	3483	2.34
5 1/4" SSSD 16 Hard Sector w/Hub Ring	3485	2.34
5 1/4" DSDD Soft Sector w/Hub Ring	3491	3.09
5 1/4" DSDD 10 Hard Sector w/Hub Ring	3493	3.09
5 1/4" DSDD 16 Hard Sector w/Hub Ring	3495	3.09
5 1/4" SSQD Soft Sector w/Hub Ring (96 TPI)	3504	2.99
5 1/4" DSQD Soft Sector w/Hub Ring (96 TPI)	3501	3.99

SSSD = Single Sided Single Density; SSSD = Single Sided Double Density; DSDD = Double Sided Double Density; SSQD = Single Sided Quad Density; DSQD = Double Sided Quad Density; TPI = Tracks per inch.

Special offer on Memorex computer tape.

If you mail your order to us and enclose prepayment, deduct \$1.00 per reel from our quantity 100 prices. This means Memorex 25JW can be as low as \$12.99 in 100 quantities. Memorex Computer Tapes are packed 10 tapes to a carton. Please order only in increments of 100 units for quantity 100 pricing. Quantities less than 100 units are available in increments of 10 units at a 10% surcharge. **Quantity discounts** are also available. Order 500 or more tapes at the same time and deduct 1%; 1,000 or more saves you 2%; 2,000 or more saves you 3%; 3,000 or more saves you 4%; 4,000 or more saves you 5% and 5,000 or more tapes earns you a 6% discount off our super low quantity 100 price. If you need further assistance or information to find the tape that's right for you, call the Memorex Computer Tape Technical Support Group at (408) 987-2937.

SAVE ON MEMOREX COMPUTER TAPE

Product Description	Part #	CE quant. 100 price per reel (\$)
Memorex IV 2400 feet Wrightline Seal	25JW	13.99
Memorex IV 2400 feet Easy Load II Cartridge	25JR	14.99
Memorex IV 1200 feet Wrightline Seal	25FW	10.65
Memorex Quantum 2400 feet Wrightline Seal	27JW	16.20
Memorex Quantum 2400 feet Easy Load II Cart.	27JR	16.99
Memorex Quantum 1200 feet Wrightline Seal	27FW	12.50
Memorex Cubic HD 2400 feet Wrightline Seal	39JW	18.99
Memorex Cubic HD 2400 feet Easy Load II	39JR	19.99
Memorex Cubic HD 1200 feet Wrightline Seal	39FW	13.99

New Memorex Lifetime Rigid Disc Pack Product Warranty

All Memorex disc packs sold by CE have a lifetime product warranty. This is your assurance that Memorex disc packs will give you a lifetime of performance and service. Only Memorex can offer you the superior reliability of their exclusive M Formula. In addition, Memorex will assist the original user in isolating and correcting any technical issues that relate to the Memorex product as well as, when appropriate, replace up to one set of read/write heads. If you need further information to find the rigid disc that's right for you, call the Memorex rigid disc compatibility hotline. Dial toll-free 800-538-8080 and ask for the *rigid disc hotline* extension 1642. In California dial 800-672-3525 extension 1642. Outside the U.S.A. dial 408-987-1642.

SAVE ON MEMOREX RIGID DISC PACKS

Product Description	Part #	CE quant. one price per pack (\$)
Mark III 5 MB. Cartridge Front Load (8 to 32 Sect.)	95-522XX-03	65.00
Top Load (1-to 24 sectors)	94-522XX-03	70.00
CMD-16 "Phoenix Type" CDC Cartridge	98-26600-31	160.00
NCR Cartridge	98-26600-32	160.00
Mark VIII 80 MB. Error Free	72-16600-03	330.00
Flag Free	72-26600-03	320.00
Mark XI 200 MB. Error Free	03-35041	720.00
Flag Free	03-35031-02	560.00
DEC Flag Free	03-35031-03	560.00
Mark XII 200 MB. NCR/CDC Flag Free	03-39001-01	515.00
Honeywell Flag Free	03-39000-01	515.00
Mark XIII 300 MB. Error Free	03-47021	795.00
Flag Free	03-47009	670.00
Mark XIV 80 MB. Unformatted Error Free	74-16600-03	365.00
Flag Free	74-26600-03	300.00
Honeywell Format Flag Free	74-26600-08	315.00
CDC Format Flag Free	74-26600-09	315.00
Mark XV 300 MB. Error Free	03-49011	825.00
Flag Free	03-49001-01	725.00

Smith-Corona TP-1 Letter Quality Printer Special Offer

Buy any Memorex product on this page, and get a Smith-Corona TP-1 letter quality printer for only \$585.00 plus \$20.00 shipping. Specify serial or parallel version.

Buy with Confidence

To get the fastest delivery from CE of your Memorex computer products, send or phone your order directly to our Computer Products Division. Be sure to calculate your price using the CE prices in this ad. Michigan residents please add 4% sales tax. Written purchase orders are accepted from approved government agencies and most well rated firms at a 30% surcharge for net 30 billing. All sales are subject to availability, acceptance and verification. All sales are final. Prices, terms and specifications are subject to change without notice. Out of stock items will be placed on backorder automatically unless CE is instructed differently. Minimum *prepaid* order \$50.00. Minimum *purchase order* \$200.00. International orders are invited with a \$20.00 surcharge for special handling in addition to shipping charges. All shipments are F.O.B. Ann Arbor, Michigan. No COD's please. Non-certified and foreign checks require bank clearance.

For **shipping charges** add \$8.00 per case or partial-case of 100 8-inch flexible discs or \$6.00 per case or partial case of 100 5 1/4-inch mini-discs. For tape shipping, add \$1.00 per reel. For Disc packs add \$10.00 per cartridge (Mark III or CMD-16) or \$15.00 per disc pack for U.P.S. *ground* shipping and handling in the continental U.S.A.

Mail orders to: Communications Electronics, Box 1002, Ann Arbor, Michigan 48106 U.S.A. If you have a Master Card or Visa card, you may call and place a credit card order. Order toll-free. Dial 800-521-4414. If you are outside the U.S. or in Michigan, dial 313-994-4444. Order your Memorex computer products from CE today.

Copyright ©1982 Communications Electronics™

Ad #090282



Order Toll-Free! **MEMOREX**
(800) 521-4414
In Michigan (313) 994-4444

COMPUTER TAPE
DISC CARTRIDGES - RIGID DISCS
FLEXIBLE DISCS

COMMUNICATIONS ELECTRONICS™

Computer Products Division

854 Phoenix □ Box 1002 □ Ann Arbor, Michigan 48106 U.S.A.
Call **TOLL-FREE (800) 521-4414** or outside U.S.A. (313) 994-4444

EDITORIAL STAFF

Tom Kneitel, K2AES
Editor

Anita Hippius
Associate Editor

CONTRIBUTING EDITORS

Gerry L. Dexter
Shortwave Broadcast

Joseph E. Jesson
RTTY Monitoring

R.L. Slattery
Survivalist Communications

Harry L. Helms, KR2H
Utility Communications

Al Muick
Alternative Radio

Bill Cheek
Rick Maslau, KNY2GL
Special Assignments

Janice Lee
Radar Detectors

Richard Barnett
Scanners

Mark Long, WA4LXC
Satellite TV

BUSINESS STAFF

Richard A. Ross, K2MGA
Publisher

James Reilly
Associate Publisher

Herb Pressman
Advertising Manager

Dorothy Kehrwieler
General Manager

Arlene Caggiano
Accounting

Cheryl Chomicki
Subscriber Services

PRODUCTION STAFF

Elizabeth Ryan
Art Director

Dorothy Kehrwieler
Production Manager

Gail M. Schieber
Production Assistant

Pat Le Blanc
Phototypographer

Hal Keith
Technical Illustrator

Cover photo courtesy of United Press International.

Offices: 76 North Broadway, Hicksville, NY 11801. Telephone 516 681-2922. Popular Communications (ISSN 0733-3315) is published monthly by Popular Communications, Inc. Corporate officers: Richard A. Ross, Pres.; Thomas S. Kneitel, Vice Pres.; Alan M. Dorhoffer, Secretary. Third class postage paid at Hicksville, NY and additional points. Subscription prices: Domestic—one year \$12.00, two years \$22.00, three years \$32.00. Canada/Mexico—one year \$14.00, two years \$26.00, three years \$38.00. Foreign—one year \$16.00, two years \$30.00, three years \$44.00. Foreign Air Mail—one year \$69.00, two years \$136.00, three years \$203.00. Entire contents copyright ©1982 by Popular Communications, Inc. Popular Communications assumes no responsibility for unsolicited manuscripts, photographs, or drawings. Allow six weeks for change of address or delivery of first issue. Printed in the United States of America. Postmaster: Please send change of address to Popular Communications, 76 North Broadway, Hicksville, NY 11801.

POPULAR COMMUNICATIONS

DECEMBER 1982

VOL. 1, NO. 4



8



34



42

FEATURES

Secrets Of Propaganda Broadcasting 8

Nations have found that it's cheaper to war with words than with missiles. Here's the inside story on this strange science; how it all began 50 years ago and where it's at today.

by Tom Kneitel, K2AES

Cordless Phone Range? Extend It! 21

Here's how to get more range from your cordless phone—it's easy!

A DX'ers New Year's Eve 22

Here's a better way to spend New Year's Eve than you've probably planned. Use POP'COMM's handy guide to special New Year's shortwave broadcasts to travel the world right from your living room!

by Gerry L. Dexter

San Francisco Police Dept. Communications 24

Here 'tis! The callsigns, frequencies, codes/signals, and even the vehicle radio ID's of this colorful and major agency!

The Continuing "Spy Numbers" Mystery 26

A DXpert examines the latest developments in monitoring these curious espionage stations, and speculates on their origins.

by Harry Helms, KR2H

POP'COMM Scans The Pinkertons 28

A national detective agency with a lively history dating back to the wild west, and you can tune them in on your scanner!

by Rick Maslau, KNY2GL

Cut Signal Fading: Use Diversity Monitoring 34

Here are some antenna tricks learned from the commercial stations. Use them to cut signal fading.

by R.L. Slattery, KA27JS

Monitoring During A Crisis 46

When the chips are down you'll want to have your scanner and communications receiver set to go. But where to listen, and what to listen for, that's the BIG question. Here's the answer.

by R.L. Slattery, KA27JS

POP'COMM Product Spotlight: Telephone Security 52

How many people are listening to your phone calls besides you? Here's a way to make your phone calls secure.

Tune In "The Rock" 74

Gibraltar offers some unique DX challenges. Here's how you can meet those challenges.

by Al Muick

DEPARTMENTS

Beaming In	6	POP'COMM Products	65
Free Radio Focus	42	Satellite View	67
RTTY Monitoring	44	Scanner Scene	70
Survival	46	Communications Confidential	72
POP'COMM Product Spotlight	52	Washington Pulse	75
Radar Reflections	54	Mailbag	78
On The Line	56	Communications Shop	79
Listening Post	60		

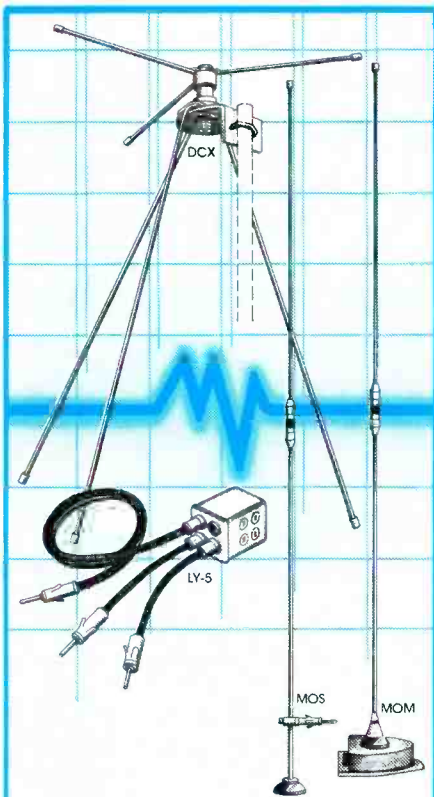

HUSTLER Monitor Antennas Bring In All Of The Action

If you aren't using a Hustler Monitor Antenna, you're missing the action!

With a Hustler Discone or Mobile Tri-Band monitor antenna, your scanner will bring in every band — clearly and quietly from greater distances. And every Hustler monitor antenna meets the highest standards of quality and engineering in the industry — our own.

Our vertically-polarized DCX Discone Model covers all public service frequencies from 40 - 700 MHz. And, its unique coilless design minimizes signal loss.

Hustler's popular Monitor Match™ utilizes your car's antenna for up to five different bands. And, Hustler Tri-Band mobile antennas offer you more mounting configurations, plus the reliability of top-grade components throughout every model.

Don't miss any of the excitement. Bring it all in with a Hustler — Still the standard of performance.



3275 North "B" Avenue
Kissimmee, Florida 32741

An **ARRL** Company

BEAMING IN

BY TOM KNEITEL, K2AES

AN EDITORIAL

Information Please!

Back in the early 1960s, I was doing a story on a county communications center in California. This was a huge mountaintop installation operating on several dozen frequencies in a whole slew of different radio services. The place was also the site of repeaters used by many federal agencies. The Assistant Communications Director of this radio paradise mentioned to me that communications monitoring was his hobby, and the more we spoke about our mutual interest in monitoring the more we realized that we had both spent many years collecting large amounts of frequency data on all manner of federal, public safety, industrial, and other stations.

After an hour of digging through one another's memory banks about the frequencies we had unearthed, we decided that we'd gather together our various frequency lists and valiantly attempt to coalesce them into something more complete than either of us had alone. Within a few weeks we had exchanged data and were both happy to learn that many information "holes" had been filled. There weren't any conditions attached to the eventual use of the data. We have kept in contact over the years, although he has long since retired and moved to a farm in the Pacific northwest.

We've both passed along the original information we had to others, added to and modified it, and I've used much of it in my writings. It made our work all the more worthwhile to think that other monitoring enthusiasts were able to tune in on some interesting fare because of our efforts. Also, it widened the scope of our efforts by causing lots of data input from others who had received the information.

Not that we had done anything particularly unique or spectacular. Many listeners, throughout the years, have pursued their own individual monitoring specialties—broadcast, utilities, federal, beacons, or whatever. For many of us, this has involved developing information relating to new stations, new callsigns, new frequencies, new schedules, etc. Actually, developing the information is, in itself, almost as much fun as actually tuning in the newly discovered stations. And part of the excitement of discovery has been the ability to share the information with those who have similar interests, exchanging it with those also seeking to expand their scope of information.

One person *here* has a contact who gave him a bits of new information, another listener *there* has dug up a scrap of data after a lengthy exchange of letters. When all of these bit and scraps are put together, through cooperation and team work, every-

body shares in it and comes out with far more information than it would have been possible for any one person to have assembled. It's the reason why radio clubs began to publish listings of the things that their members have heard; it's the fraternity of cooperation between monitors. All of this appears to be going through an interesting, curious, and *not* particularly pleasant change—and it's not a change for the better.

What I've been noticing is a trend away from this open exchange of information and, instead, a trend towards a type of *dog in the manger* attitude. Maybe it's a byproduct of the "Me Generation" that we've heard about. What's just as bad is a newly emerging breed of elitists who seem to have set up shop in order to advise others of what information they should or shouldn't have. Oh yes, monitors still develop lots of new information through various contacts and monitoring efforts, but some of those monitors aren't much interested in sharing it, except for perhaps their closest friends. In conversations and written communications with some of those who are into this bag, I've discovered several basic viewpoints.

For instance, one monitor told me flatly, "It took me a long time and a lot of work to assemble this data. Anybody else who wants it can go out and dig it up for himself." It's almost as if other persons having the information were going to somehow diminish this fellow's ability to listen. Did he assume that more than one person listening on a frequency would reduce the signal strength? I never did figure out his logic, but he wasn't alone with his point of view.

Another said that he had obtained the information from a very close friend who had, in turn, received it from another pal. In any event, he had to promise that he wouldn't pass the information on to any other listeners. When I finally coaxed the information out of the guy, I found, to my surprise, that it consisted of data that had been freely circulating in monitoring circles for many months! Half the listeners in North America undoubtedly had been given the same data "in the strictest confidence" by a friend who made them promise not to pass it along. It's the 1980s version of the old secret handshake and password nonsense.

One information-laden monitor claimed that the data he had was simply "too sensitive" to share with other listeners, although he did not explain by what mysterious process he had given himself an appropriate security clearance. Obviously it was okay for

(continued on page 79)

Entirely professional level!

You'll find the difference the more you use it.

ULTIMATE QUALITY, NRD-515



Receiver, NRD-515

SPECIFICATIONS

Receiving frequency range: 100kHz to 30MHz continuous (30 bands)
 Receiving modes: USB/LSB/CW/RTTY/AM
 Receiving system: Up conversion type
 Double superheterodyne
 First IF: 70.455MHz
 CW/SSB AM
 0.5µV 2µV
 1.6 to 30MHz
 100 to 1600kHz
 Selectivity: 6kHz/2.4kHz/0.6kHz/0.3kHz
 (*Option)
 Stability: Within 50Hz/one hour
 Power requirements: AC 100/117/220/240V, 50/60Hz, 50VA
 Dimensions and Weight: 340mm(W)×140mm(H)×300mm(D), Approx. 7.5kg
 Preset memory (Option): 24ch.
 Frequency stability: Less than 50Hz per hour after warming up.
 Image rejection ratio: 70dB or more
 IF rejection ratio: 70dB or more
 Input impedance: 50 to 75 ohms, unbalanced
 AF outputs:
 Speaker output: 1W or more (4 ohms)
 Record/line output: 1mW or more (600 ohms)

Highest grade all-wave receiver

NRD-515

Best for 59

Transmitter, NSD-515



SPECIFICATIONS

Rated output power: 100W NSD-515 (50W 28MHz band)
 1.8MHz 2.0MHz/3.5MHz 4.0MHz/
 7.0MHz 7.3MHz/14.0MHz-14.35MHz/
 21.0MHz 21.45MHz/28.0MHz-29.0MHz/
 29.0MHz-29.7MHz/Optional new bands
 approved by IARCC 79
 10.1MHz-10.15MHz 18.068MHz-
 18.168MHz/24.89MHz-24.99MHz/
 A3J (USB/LSB) A1 (CW) F1 (RTTY)

Mode of emission:

• For more information please contact to;



Since 1915

Japan Radio Co., Ltd.

AUSTRALIA: N.S.W.—EMONA ELECTRONICS PTY LTD Phone: 398-6378
 Victoria—VICOM IMPORTS PTY LTD Phone: (03) 62 6931
FINLAND: Kotka—VISI RADIO OY Telex: 53260 VISI SF
FRANCE: Paris—SOCIÉTÉ G.E.S. (GENERAL ELECTRONIC SERVICES) Phone: (1) 345 35 92
CANADA: Vancouver—GLENWOOD TRADING CO. LTD Phone: 604 984 0404
GERMANY: Hannover—RICHTER & CO. Phone: (0511) 352 1111
ITALY: Milanese—TECHNOVENT, ITALIA SRL Phone: 02 32 83 089

MAIN OFFICE: Mori Building Fifth, 17-1, Toranomon 1-chome, Minato-ku, Tokyo 105, Japan Cable Address: "JAPANRADIO TOKYO"
 Phone: (03) 591-3451 Telex: 0222-3068

U.S.A. LIAISON OFFICE: T. Hayashi,
 120 East 56th Street, New York, New York 10022
 Phone: 212-355-1180 Telex: 230-645636 JAPANRADIO NYK

SWITZERLAND: SEICOM AG Phone 064 515566
U.K.: Derbyshire—LOWE ELECTRONICS, LTD Phone 0629 2430
U.S.A.: Ohio—UNIVERSAL AMATEUR RADIO, INC. Phone: (614) 866-4267

CIRCLE 39 ON READER SERVICE CARD



Emerging nations all seem to feel a need to establish their position in the world community by explaining their philosophies and knocking whatever regime was in power prior to their arrival on the scene. This falls under the category of propaganda.

Nations Have Found That It's Cheaper To War With Words Than With Missiles – But It's Just As Much Of A Science!

Secrets Of Propaganda Broadcasting

BY TOM KNEITEL, K2AES, EDITOR

One of the primary weapons of the British/Argentine battle for the Falkland/Malvinas Islands was radio. This involved not only the communications systems aboard the ships and aircraft, and the radar, but your basic broadcasting transmitters as well.

No sooner had the Argentine forces commenced their military activities when shortwave transmitters in Argentina began firing massive barrages of words into the world's airwaves. From powerful shortwave and medium wave transmitters, Argentina felt the need to explain its actions to its neighbors and the rest of the world — try to show that it felt its position was just and right. It was the art and science of propaganda in action, the systematic, widespread promotion of certain ideas and doctrines to further their cause. Of course, there were those who decried some of Argentina's statements, claiming that they were either distorted or even barefaced lies.

The British were not about to just sit there at their receivers and casually shake their heads at such antics. Even before the British fleet arrived on the scene to do battle for the Falklands, the Defense Ministry in London

announced that it would broadcast two radio programs a day in Spanish to the Argentine military forces on the islands in order to present the British view of events.

To broadcast their programs, the British took over one of the BBC's four mid-Atlantic transmitters located on Ascension Island. They promptly named it Radio Atlantico del Sur (Radio South Atlantic).

The British explained their move by saying, "The program . . . will contain some popular music as well as news items. News reporting will be strictly factual; *the station will not indulge in propaganda.*" Oh yes, I forgot to mention that "propaganda" is somewhat of a dirty word and is what, in polite circles, best describes what the *other* side is doing.

Defense Ministry spokesman Ian McDonald said the broadcasts were intended to counter Argentine claims "which the next day are contradicted by events . . ." The hoped-for result of this is to insure insofar as we can that the Argentine garrison on the Falkland Islands appreciates the true position that they're in . . ." Broadcasts commenced in late May.

The BBC's programming over Radio Atlantico del Sur, which purported to present both sides of the situation with equal vigor, promptly came under attack from the British public and from government ministers, including Prime Minister Thatcher. They felt that such an approach would minimize the effectiveness of the broadcasts in pointing out the British position; even if the BBC wasn't interested in broadcasting propaganda, it seemed like everybody else was!

For propaganda, indeed, is a most powerful weapon and not to be left to idealistic news reporters! It is a highly sophisticated and subtle psychological technique which, when properly used by experts, is as effective as any military hardware. Some have pointed out that it may even be *more* effective—for you can bomb a city and destroy its citizens or you can attempt to use propaganda to change the minds of the people—and 50 people with changed ideologies are far more useful to a cause than several thousand charred corpses.

Of course, a raging war with bullets and missiles is always immediate cause for the commencement of broadcast propaganda.

More often than not, however, the use of broadcast propaganda to present various political ideologies exists when no war has been declared and no troops are engaged in battle. Radio propaganda is, nevertheless, a war of words, and when nations wish to present their political ideologies to outsiders, this is the first and preferred course of action. Even as this is being written, the United States is getting ready to step up the radio propaganda battle with Cuba.

Cuba recently added new and more potent transmitters to its propaganda arsenal and plans to double the number of AM broadcast stations within its borders. Castro's plan to build 96 new AM stations and to soup-up the power at many of the 90 existing transmitters would successfully interfere with night time broadcasts throughout North America. "The implications for American Radio stations are frightening," said a National Association of Broadcasters report. "The effect on the public is an enormous loss of news, information, and entertainment." Frankly, American broadcasters have been alternately angered and frightened by this proposed step-up in the hardware of the war of words.

The Dept. of Defense, the FCC, Congress, and even the White House have become a part of these developments. Washington has long squawked that Cuba has been illegally broadcasting omnidirectional radio signals that are being received throughout the hemisphere and are in blatant violation of international broadcasting agreements.

Although coming a month after Castro's announced plans, the American government's proposal for the establishment of a station to be called Radio Marti was supposedly not a direct result of any broadcasting activities in Cuba. Radio Marti, named after a Cuban hero of several generations past, will require \$17 million to construct for operation from its Florida location. A 50 kilowatt transmitter is part of the plan, which is intended to let our government "tell the Cuban people the truth about their country" with broadcasts of news, social, political commentary, and perhaps some entertainment.

Castro reacted to these developments by showing that he's able to use gigantic transmitters to jam American stations. In Castro's radio broadcast arsenal is some heavy artillery—half-million watt Czechoslovakian transmitters. Last August he demonstrated their potency.

Castro's reaction then brought a counter-reaction from our side which speculated about the use of FM or shortwave transmitters to bombard the island with transmissions from ships or aircraft. Or, it could always make use of the old Voice of America facility at Marathon, FL.

Meanwhile, the proposed Commission on Broadcasting to Cuba (which would operate Radio Marti) is eagerly awaiting the funds to get the project underway. And, perhaps recalling the previous radio propaganda war with Cuba some 20 years ago, William Krause (Chief Engineer at broadcast

RADIO ATLANTICO DEL SUR

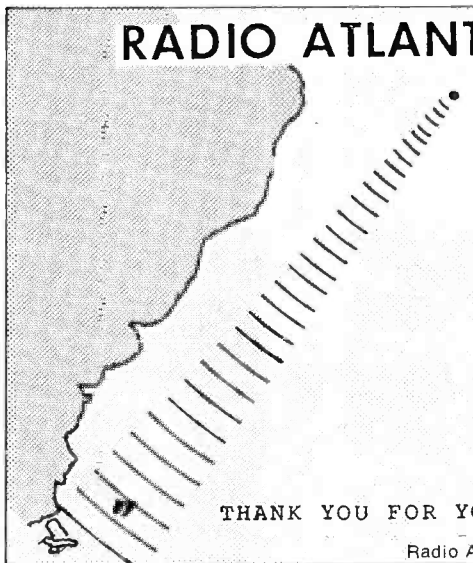

BRINGING TRUTH TO THE FRONT

SCHEDULE	
AM 9700 KHz	0830 – 0930 GMT
PM 9710 KHz	2300 – 0200 GMT

THANK YOU FOR YOUR LETTER.

Radio Atlantico del Sur, PO Box 408, London, UK.

Current world tensions produce interesting propaganda broadcasters, like the British station Radio Atlantico del Sur, established to bring "truth" to Argentine troops stationed in the Falklands. As with most such broadcasters, the term "propaganda" is shunned in connection with their own programming and is only applied to what "the other side" broadcasts. This card is in the collection of DXer Don Jensen.

station WNBC in New York) commented, "I don't know what the answer is . . . for commercial radio it would be a disaster."

Twenty years ago, the CIA had secretly financed an anti-Castro station called Radio Swan (also called Radio Americas). It poured out endless hours of propaganda and also did a pretty good job of irritating Castro, while causing havoc to two clear channel American broadcasters who happened to have the misfortune of being authorized by the FCC to operate on 1160 kHz, the frequency selected by the CIA for its operations.

There are few nations that aren't into radio propaganda on one level or another in its many forms and guises. Our own Voice of America, Radio Free Europe, and Radio Liberty are certainly strategic weapons in the international propaganda wars, although not to be outdone by Radio Berlin International, Radio Moscow, Radio Prague, Voice of Vietnam, Radio Havana, and scores of others from all positions along the many political lines that divide the nations of the world. The Middle East political situation has been the cause of enormous amounts of propaganda ranging from hysterical ranting and raving to in-depth "serious" explanations attempting to justify the actions and reactions of the nations there. If the participants have not been entirely successful in convincing the world of the sanity of their activities and their ideologies, then certainly it sounds as if they have convinced themselves that they're right.

Almost every newly formed nation is on the air telling its story to the world and seeking acceptance. Even nations which hope to exist at some time in the future are busy broadcasting propaganda from clandestine transmitters hidden in mobile radio vans and basements. Basically, when you're talking about international broadcasting, more often than not you're talking about radio prop-



The Voice of America is the propaganda arm of the United States. VOA officials bristle at the use of such a description, however, saying that they broadcast only the truth, information, and cultural programs — insisting that they never engage in propaganda. Listeners probably would consider the VOA basically a propaganda oriented operation. Actually, the word propaganda has a nasty connotation when it comes to broadcasting.

aganda; even if it's not called by that name, it's still a matter of trying to convince or persuade others to change their political ideas. Fact is that although propaganda is generally accepted as relating to only political matters, in truth it actually incorporates broadcasting which attempts to modify religious, social, economic, industrial, or other preferences and beliefs.

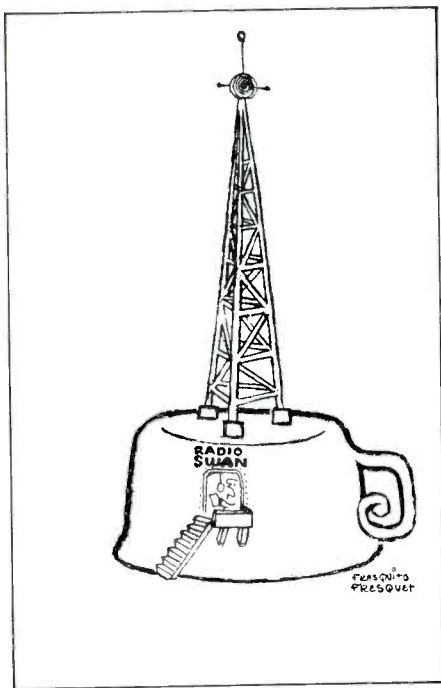

Radio Swan, a/k/a Radio Americas, was a CIA-run anti-Castro propaganda broadcaster of the 1960s, although our government not only denied any connection with its operation but sometimes pretended that it had no knowledge that it existed while it was running 50,000 watts from U.S. territory! Castro didn't think much of the station and this cartoon from a Cuban magazine likened the station's broadcasts as something coming from a chamber pot!

Where Did It All Begin?

Many will point to 1936 as the kickoff point. That year saw the Italian-Ethiopian conflict and the Spanish Civil War. Shortwave monitors heard Italian stations broadcasting doctored "news" from the front while simultaneously the station in Addis Ababa was giving its version. The Spanish Loyalist station at Madrid was also giving its side of that nation's problems, while the rebels in Seville and on the Canary Islands got in their 2¢ worth. This was very lightweight and primitive propaganda, however.

Actually, you'd have to look back to 1933 to find the real roots of what we today consider propaganda broadcasting on a grand scale. In 1930, there were only three shortwave broadcasting stations in all of Europe. But, by early 1941, there were at least 40 in full operation and many more under construction. Most of the growth in this area was initiated by Germany, commencing almost immediately after Adolf Hitler was named Chancellor in 1933. In retrospect, it would seem that Hitler's long range plans for world domination included the heavy reliance upon international broadcasting. He wasted no time.

Within only 60 days of taking power, on April 1, 1933, Hitler opened the German experimental shortwave station at Zeesen.

Its antenna was directional — aimed at the United States — and it used its 4 kilowatt transmitter to broadcast for two hours daily. The transmitting power was quietly increased to 7 kilowatts, and by February of 1934, directional antennas for Africa and South America had been erected and placed in operation. In 1935, antennas for South Asia and Central America were put into use and the station dropped the facade of being experimental.

In 1936, seven more transmitters were added and the station was running 40 kilowatts, announcing that the improvements were "to better serve the listening world with news of the Olympic Games." The Olympic Games, which were held in Berlin that year, provided a large boost in the German station's audience and Hitler seized the opportunity to make the most of the situation and assure that his worldwide listening audience would stay tuned even after Jesse Owens and the rest of the athletes went home with their medals. To do this, his station responded to each and every listener who wrote in. The listeners were showered with travel literature, Christmas cards, recordings, books on German history and folklore, program folios, picture postcards, photographs, and many other souvenirs and gifts.

By 1938 and '39, when Hitler moved in on Austria, Poland, Hungary, Czechoslovakia, etc., he not only had the broadcasting facilities to tell his story to the world, he also had a huge listening audience that had been freely pampered and bribed with very appealing gifts and who were more than likely going to be sympathetic to his explanations. Moreover, the station in Zeesen became the nucleus of a broadcasting network which was augmented with transmitters in each new nation that was conquered. The Germans were also successful in buying air time on many South American stations to rebroadcast their programs.

Before almost anybody knew what had happened, Hitler's propaganda machine

had a full head of steam. World powers were caught off guard. Reacting to the German propaganda assault, in the summer of 1940, conferences were held between the State Department, the FCC, and representatives of the handful of American shortwave broadcasting stations — all of which were privately owned and mostly operating with powers ranging from 10 to 35 kilowatts. Two stations were running high power: WLWO in Mason, OH, which ran 50 kilowatts, and WGEO in South Schenectady, NY, running 65 kilowatts (but authorized to run 100 kilowatts).

Plans were hastily drawn up to increase the power of almost all of the stations to 50 kilowatts and also to utilize more efficient beam antennas to make them sound like 500 kilowatts. Much of the cultural programming these stations had been carrying — operas, symphonies, concerts, dramas — was severely cut back in favor of increased news programs in Spanish, Portuguese, French, Italian, German, and English. While the cultural programs did intend to "show us in a better and fairer light" (as one broadcaster of the day stated), they just weren't enough to counter the massive amount of propaganda pouring out of Germany and stations connected into the German broadcast arsenal.

America wasn't alone in gearing up for the propaganda war. The BBC flew into the fray with fierce dedication. The Free French were on the air, as were the Norwegians and others, often using low powered makeshift portable transmitters. And when Radio Tokyo joined the propaganda war, they were countered by broadcasters in the Pacific area, such as Manila Calling. But, frankly, it was the Germans who had gotten the first shots off in the war of words, and it seemed that they had done their homework well. They had written the radio propaganda book, and they taught their friends the finer points of this unique weapon's use. Even today, 40 years later, we still remember some

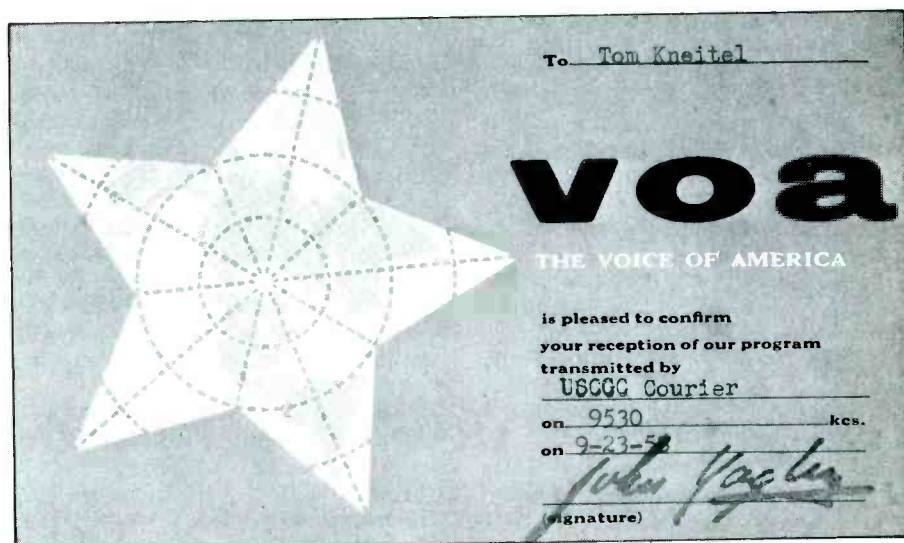

All the better to talk to you, my dear! In the 1950s, the VOA set up a powerful relay transmitter aboard the U.S. Coast Guard Cutter Courier and anchored it at the Island of Rhodes in order to get a better signal into Eastern Europe and the USSR.

of the air personalities of the Axis powers—Axis Sally, Lord Haw Haw, Tokyo Rose—so powerful was their impact on the times.

Actually, it took us a while to analyze and figure out that there was more to waging propoganda warfare than it seemed at first. Indeed, it was a sophisticated technique and Uncle Sam devoted an enormous amount of time and effort to grasping its nuances in attempting to meet its challenge.

Unlocking Propaganda's Secret Techniques

Under the direction of Harold N. Graves, Jr., and financed by the Rockefeller Foundation, a group called the Princeton Listening Center (at Princeton, NJ) was established in late 1939. It represented America's first serious attempt to understand the technique of radio propoganda warfare.

Similar listening posts were later (1941) being established in other areas of the nation by the FCC and the Defense Communications Board. Their operation was somewhat different than the Princeton station.

At Princeton, from mid-afternoon to almost midnight each day, monitors sat at two communications receivers connected to two recording machines which were making a permanent record of every word of propoganda uttered over Radio Berlin. By mid-1941, they had nearly 9,000 wax recording cylinders filled with 100,000 minutes of propoganda encompassing 8 million words. A staff of translators would arrive for work every day and find as many as 40 cylinders awaiting their efforts to type up English language translations.

On each typed sheet, in the right hand margin, a coding expert would jot down symbols to indicate the propoganda theme used by the speakers. Such symbols were intended to enable later research workers to trace the development of any given theme with a minimum of effort. After coding, the sheets were bound and filed in a research library according to language and transmitting station.

Researchers who specialized in various war fronts, aided by means of additional reports, graphs, summaries, and intelligence, would then attempt to reduce the propoganda to its most basic and simple elements. Once these elements were discerned, they came to the realization that propoganda warfare was no mere haphazard outpouring of words, but a carefully calculated and orchestrated psychological weapon that could be used by the Allies to wage the same type of warfare effectively in return, and even to anticipate Axis military activities.

Germany, they discovered, in its broadcast warfare against Britain and the United States, made use of a half dozen distinctive types of propoganda techniques. The Princeton Listening Center categorized each of these methods and noted that they fluctuated in comparison to one another along with the rise and fall of political and military events.

One technique was known at Princeton

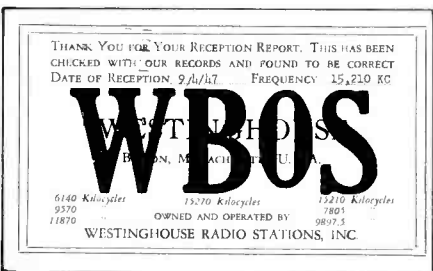
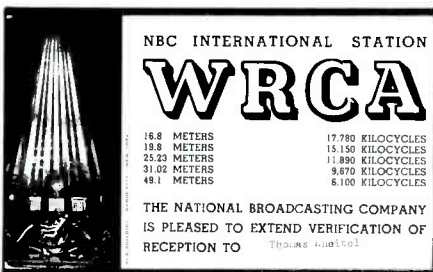
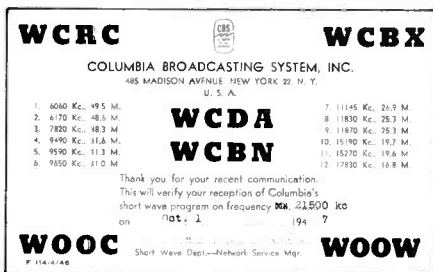
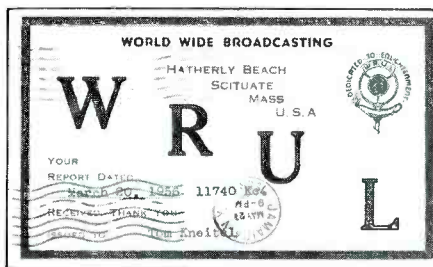

When World War II broke out, the Nazis had an established propoganda network going full blast. All we had were a few isolated low powered commercial shortwave broadcasters that were hastily pressed into service to fight back in the battle for the airwaves. These QSLs are from some of these stations in their post-WWII days.

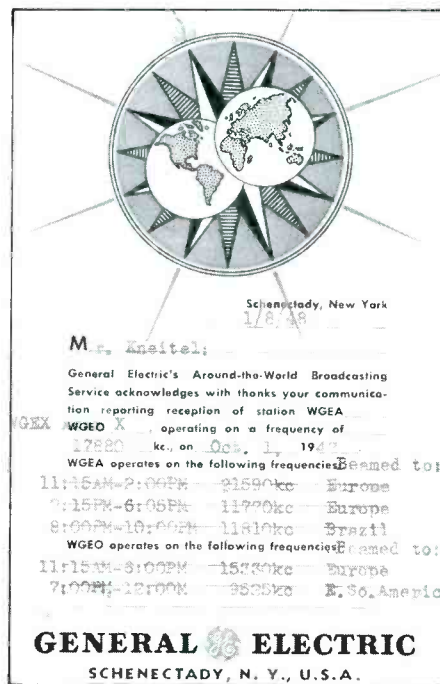
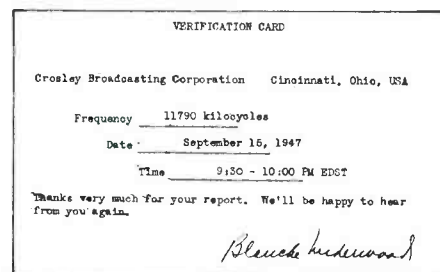

as *The Propaganda of Terrorism*. This always reached a peak just before a brutal all-out attack from the air. It was the simplest and least subtle of the weapons used in the war of words and nerves. Stressed were the devastation of Warsaw, the destruction of Rotterdam, the terrors which lay ahead for women and children of enemy cities. This theme was repeated over and over. As an adjunct of that theme, the Germans eventually started preceding their announcements of each torpedoed ship with the doleful tolling of a bell; this produced an especially depressing effect.

Such propoganda has the benefits of softening up the enemy, producing confidence in friendly nations and allies, and possibly convincing neutral nations that their best interests would not be served in siding with the enemy. *The Propaganda of Terrorism*, however, rarely changes the actual course of events, although it can accelerate or slow them down.

In the early days of the war, Germany made heavy use of *The Propaganda of Paralysis* in its American broadcasts. In an effort to further stall or slow down the natural

drift towards aiding Britain, it attempted to discredit the press and make the people suspicious of what was printed and what was released by the government. It emphasized defeatism, the certainty of Britain's fall, the distaste which would come of siding with a loser. It praised any American made statements opposing foreign entanglements and lauded America's decision to keep its ships out of European waters. Before each invasion of a neutral country, when Americans might be tempted to rush into action, the tempo of this category of propoganda was accelerated.

At the same time, an attempt to drive a wedge between Britain and the United States by *The Propaganda of Division* zoomed before each major move of the German Army. Berlin's broadcasters, under the direction of Hitler's Minister of Popular Enlightenment and Propaganda, Paul Josef Goebbels (one of the "fathers" of modern psychological warfare), played up such

Listen to your planet on a short-wave receiver!

Communications Electronics, the world's largest distributor of radio scanners, is pleased to introduce Panasonic Command Series shortwave receivers. Panasonic lets you listen to what the world has to say. Unlike a scanner, a Command Series radio lets you listen to shortwave broadcasts from countries around the world, as well as the U.S.A. It's the space age shortwave performance you've been waiting for...at a down to earth price you can afford.

All Panasonic shortwave receivers sold by Communications Electronics bring the real live excitement of international radio to your home or office. With your Command Series receiver, you can monitor exciting radio transmissions such as the BBC, Radio Moscow, Ham Radio and our own Armed Forces Radio Network. Thousands of broadcasts in hundreds of different languages are beamed into North America every day. If you do not own a shortwave receiver for yourself, now's the time to buy your new receiver from CE. Choose the receiver that's right for you, then call our toll-free number to place your order with your credit card.

We give you excellent service because CE distributes more scanners and shortwave receivers worldwide than anyone else. Our warehouse facilities are equipped to process thousands of orders every week. We also export receivers to over 300 countries and military installations. Almost all items are in stock for quick shipment, so if you're a person who needs to know what's really happening around you, order today from CE.

Panasonic® RF-6300

List price \$749.95/CE price \$529.00
Bands: LW 150-410 KHz., MW 520-1610 KHz., SW1-5 1.6-30 MHz., FM 87.5-108 MHz.

The new Panasonic RF-6300 Command Series PLL synthesized 8-band portable communications receiver, lets you hear the world. The RF-6300 has features such as microcomputer pre-set tuning and PLL quartz synthesized digital tuner. Microcomputer stores up to 12 different frequencies for push-button recall. FM/MW/LW/SW1-5 reception. Manual tuning knob. Wide/Narrow bandwidth selector. Double superheterodyne system. Fast/Slow manual tuning. Built-in quartz digital alarm clock. 5 inch dynamic PM speaker. 3 antennas. Multi-voltage. Detachable AC cord. Operates on 6 "D" batteries (not included). Made in Japan.



Panasonic RF-6300



RF-4900

Panasonic® RF-4900

List price \$549.95/CE price \$399.00
Bands: MW 525-1610 KHz., SW1-8 1.6-30 MHz., FM 88-108 MHz.

The Panasonic RF-4900 shortwave receiver features a 5-digit fluorescent display for all 8 SW bands, as well as for AM/FM. AC or battery operation. Full coverage from 1.6 to 30 MHz on SW. Covers SSB and CW. Premix Double Superheterodyne. Fast/slow 2 speed tuning. AFC Switch on FM, narrow/wide selectivity switch for AM and SW. Antenna trimmer. Calibration control. FET RF circuit. Mode switch for AM-CW/SSB. BFO Pitch control. ANL switch for AM. RF gain control. Tuning-Battery meter with meter function switch. Separate bass and treble tone control. Dial light switch. Digital display on/off switch. Separate power switch. Rack type handle. Made in Japan.

Panasonic® RF-3100

List price \$369.95/CE price \$269.00
Bands: MW 525-1610 KHz., SW1-29 1.6-30 MHz., FM 88-108 MHz.

The Panasonic RF-3100 portable 31-Band portable radio has PLL Quartz-Synthesizer tuning that "locks" onto SW stations. Operates on AC or battery. SW frequencies from 1.6 to 30 MHz. are in 29 bands. All-band 5-digit frequency readout. Horizontal design with front mounted controls for shoulder strap operation. Double superheterodyne for clean SW reception. BFO pitch and RF gain controls. Separate bass and treble controls. Wide/Narrow bandwidth selector. Meter for tuning and battery strength. LED operation indicator. Meter light switch. 3 1/2" PM dynamic speaker. Comes with detachable shoulder belt. Battery power (8 "D" batteries not included). Made in Japan.

Panasonic® RF-2900

List price \$349.95/CE price \$249.00
Bands: MW 525-1610 KHz., SW1-3 3.2-30 MHz., FM 88-108 MHz.

The Panasonic RF-2900 is a portable five-band shortwave radio with digital five digit fluorescent frequency display. Full coverage from 3.2 to 30 MHz. on SW. Covers SSB and CW. Double superheterodyne receiver. Fast/slow 2 speed tuning. AFC switch on FM, narrow/wide selectivity switch for AM and SW. FET RF circuit. BFO switch and pitch control. RF gain control. Tuning battery meter. Separate bass/treble tone control. SW calibration control. Dial light switch. Digital display on/off switch. Separate power switch. Detachable dial hood included. Rack type handle. Includes whip antenna and ferrite core antenna, speaker, earphone, recording output jacks, AC line and detachable adjustable shoulder belt. Made in Japan.



Command Series RF-2900

Panasonic Command Series

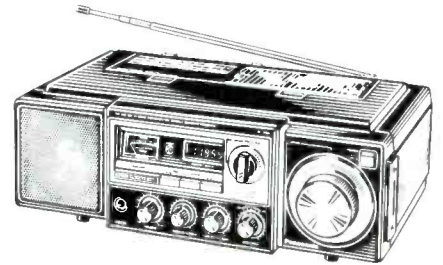

Panasonic RF-3100

TEST ANY RECEIVER

Test any receiver purchased from Communications Electronics for 31 days before you decide to keep it. If for any reason you are not completely satisfied, return it in original condition with all parts in 31 days, for a prompt refund (less shipping and handling charges).

NATIONAL WARRANTY SERVICE

All Panasonic receivers listed in this ad are backed by a two-year limited warranty on parts and labor. In addition, this warranty is backed by a broad network of Panasonic service centers. For two years after original purchase, Panasonic will repair or replace your receiver if purchased and retained in the U.S.A. Customer must take it to an authorized service center. Warranty does not cover damage from abuse, misuse, or commercial use. Proof of purchase is needed for in-warranty service.

BUY WITH CONFIDENCE

To get the fastest delivery from CE of any receiver send or phone your order directly to our Consumer Products Division. Be sure to calculate your price using the CE prices in this ad. Michigan residents please add 4% sales tax. Written purchase orders are accepted from approved government agencies and most well rated firms at a 10% surcharge for net 10 billing. All sales are subject to availability, acceptance and verification. Prices, terms and specifications are subject to change without notice. Out of stock items will be placed on backorder automatically unless CE is instructed differently. International orders are invited with a \$20.00 surcharge for special handling in addition to shipping charges. All shipments are F.O.B. Ann Arbor, Michigan. No COD's please. Non-certified and foreign checks require bank clearance.

Mail orders to: Communications Electronics, Box 1002, Ann Arbor, Michigan 48106 U.S.A. Add \$12.00 per receiver for U.P.S. ground shipping and handling. If you have a Master Card or Visa, you may call and place a credit card order. Order toll free in the U.S.A. Dial 800-521-4414. Outside the U.S. or in Michigan, dial 313-994-4444. Order your Panasonic Command Series receiver today at no obligation.

CE logos are trademarks of Communications Electronics. Panasonic is a registered trademark of Panasonic Company, a Division of Matsushita Electric Corporation of America.

Copyright © 1982 Communications Electronics Ad # 090182



Consumer Products Division

854 Phoenix □ Box 1002 □ Ann Arbor, Michigan 48106 U.S.A.
Call TOLL-FREE (800) 521-4414 or outside U.S.A. (313) 994-4444

Introducing incredible tuning accuracy at an incredibly affordable price: The Command Series RF-3100 31-band AM/FM/SW receiver.* No other shortwave receiver brings in PLL quartz synthesized tuning and all-band digital readout for as low a price.† The tuner tracks and "locks" onto your signal, and the 5-digit display shows exactly what frequency you're on.

There are other ways the RF-3100 commands the airways: It can travel the full length of the shortwave band (that's 1.6 to 30 MHz). It eliminates interference when stations overlap by narrowing the broadcast band. It improves reception in strong signal areas with RF Gain Control. And the RF-3100 catches Morse



RF-6300 8-band AM/FM/SW

communications accurately with BFO Pitch Control.

Want to bring in your favorite programs without lifting a finger? Then consider the Panasonic RF-6300 8-band AM/FM/SW receiver (1.6 to 30 MHz) has microcomputerized preset pushbutton tuning, for programming 12 different broadcasts, or the same broadcast 12 days in a row. Automatically. It even has a quartz alarm clock that turns the radio on and off to play your favorite broadcasts.

The Command Series RF-3100 and RF-6300. Two more ways to roam the

globe at the speed of sound. Only from Panasonic.

*Shortwave reception will vary with antenna, weather conditions, operator's geographic location and other factors. An outside antenna may be required for maximum shortwave reception.

†Based on a comparison of suggested retail prices.

This Panasonic Command Series™ shortwave receiver brings the state of the art closer to the state of your pocketbook.



With PLL Quartz Synthesized Tuning and Digital Frequency Readout.

Panasonic
just slightly ahead of our time.
CIRCLE 49 ON READER SERVICE CARD

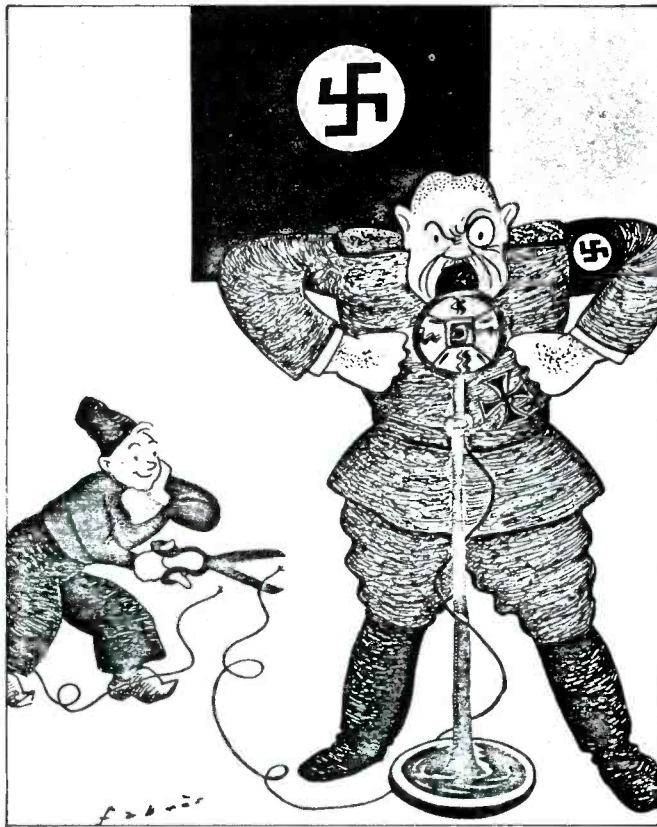

Harold N. Graves, Jr., Executive Director of the Princeton Listening Center, with J.R. Snedeker, radio technician (seated), at the two communications receivers used to monitor German propaganda broadcasts during the early 1940s.

This poster was circulated in Holland during WWII by the Allies in an effort to get Dutch partisans to sabotage the broadcasting station that the Nazis had taken over.

things as the seizure of American mail by the British and previous differences between the two nations going back as far as The War of 1812 and even the American Revolution. They trotted out every single major and minor "incident" they could dig up from the history books.

Ill feeling of another kind was the aim of *The Propaganda of Dissention*, as Princeton called it. By recalling dissatisfactions, grievances, and "class" hatreds within the United States itself, this approach sought to produce internal quarrels, disharmony, and suspicion. By slanting and distorting news items, it called attention to the differences between labor and management, between religious and racial groups, between people of different national origins, age groups, political affiliations and even persons living in different regions. The goal of that approach was to produce a continuing friction and prevent the nation from becoming an efficient and smooth running machine.

In the United States, at that time, there was a so-called "Fifth Column" scare. This was a suspicion that some within this country might be spying for Germany or at least be actively supporting the Nazi philosophies. That brought yet another propaganda tactic to the fore. It was *The Propaganda of Confusion*. In rapid succession, Radio Berlin would broadcast varying accounts of the fifth column. First, they maintained that it was all sheer imagination. Then they veered quickly to the idea that it was something concocted by the British. And, as quickly, they took a new tack. It was, they said, merely a bogeyman thought up by the

Administration to distract attention from its failures. By pointing up several directions simultaneously, the idea was to bewilder and confuse those who feel compelled to act.

Finally, Princeton noted *The Propaganda of Variety*. For each aggressive move Hitler's Germany made, the propagandists presented innumerable reasons, explanations, and arguments to support those actions in an effort to justify them. By giving a wide variety of arguments, the propagandist tries to suit every listener. If one explanation doesn't sit too well, yet another may well carry conviction. This tactic, like a verbal shotgun instead of a rifle, attempts to present events in the most favorable light.

Close study of these different types of broadcast propaganda enabled the Princeton monitors, on many occasions, to fortell coming events. *The Propaganda of Division*, for example, rose to a peak in the spring of 1940 as the German forces overran Belgium, Holland, and France. Later in the summer, it began to subside and the experts concluded that the expected invasion of Britain had been postponed.

By noting a sudden jump in terrorism propaganda, Princeton experts were able to predict, within a few days, the major air offensive against London. Different types of propaganda, they found, preceded attacks by air and by sea. Air attacks were heralded by terrorism broadcasts, while division type propaganda usually foretold of offensives from the sea — telling of the suffering in nations blockaded by Britain in order to justify fierce attacks upon shipping by Nazi U-boats and aircraft.

Even within the six major propaganda categories, there were strange telltale combinations of ingredients which went into their makeup. Some themes were predominantly anti-American, while at other times there was a pro-American approach, and this was mixed in with differing amounts of anti-British and pro-German sentiment. All of this very carefully measured out to suit the psychological effect which was desired to coordinate with a specific military event.

In Vivid Black & White

Radio propaganda sometimes is said to fall into categories of *black* and *white*. White category radio propaganda is really what you usually hear during peacetime from Radio Moscow, The Voice of America, and other major stations. There aren't many gross deceptions or blatant falsehoods. Essentially what listeners hear is the truth, but nevertheless presented in a manner so as to convince the listener that the nation doing the broadcasting is the "good guy" with the best approach and political viewpoint. The idea is to build credibility with the listeners, not even once forgetting the reputation for honesty may be of use at some point in the future. The proponents of this approach feel that today's listeners have too many other media available to convince most of the audience to accept a constant stream of hogwash, although this isn't to say that what is presented hasn't been carefully worded for the proper subtle effect sought. Of course, during periods of crisis and open hostilities, *the truth, the whole truth, and nothing but*



One of the interesting propaganda patterns noted was that the type and amount of propaganda broadcasting used by the Germans varied with their military activity. Eventually we figured out how to predict some attacks by analysis of the propaganda in use at a given time.

the truth usually gets a little more difficult to locate as the stations slip into a category of gray propaganda.

When the Bay of Pigs invasion took place in 1961, the Voice of America moved over into the gray area when it denied any American involvement in the CIA-backed caper. Obviously, the VOA was banking on its long-established listener credibility to get that tall tale to stick. The Russian invasion of Afghanistan was accompanied by Radio Moscow's use of shades of gray propaganda in an attempt to justify the action.

So was Israel's attack upon the *USS Liberty*, a U.S. Navy intelligence vessel, a few years ago. The attack left 34 dead and 71 wounded. However, the Israeli Broadcasting Authority explained this grayly as "an accident." It was nothing very original.

When aircraft of the Imperial Japanese Navy sank the *USS Panay*, an American gunboat, while lying at anchor in international waters on December 12th, 1937, they said that it was "an accident." It had been clearly demonstrated that, like the attack upon the *USS Liberty*, the *Panay* attack was quite deliberate. The world situation being

what it is, listeners hear gray propaganda very often.

Gray propaganda is also in use when nations attempt to get as much mileage as possible out of the embarrassing situations in which their enemies find themselves. The idea is to fan any sparks into flames by capitalizing upon the other nation's crisis. Radio Moscow went into high gear with the Falkland crisis, the Israelis in Lebanon, the assassination of Martin Luther King and the Kennedys. Watergate, the American hostages in Iran, and innumerable other events. They (VOA) didn't miss the opportunity to offer similar coverage on the Russian invasion of Afghanistan, the Polish imposition of martial law and the Solidarity situation, Cubans leaving Castro in boats.

Black propaganda, the cloak and dagger stuff, is the area where creativity, imagination, and sneaky activities are at their peak of perfection. It's the realm of "the big lie" and all manner of really fascinating deceptions. The Third Reich got the ball rolling in this department, too. Not only was Berlin pumping out massive doses of their standard propaganda onto the world's airwaves, but Herr

Goebbels had a few other clever gambits in his bag of tricks.

Almost simultaneously in early 1940, two new stations were noted. Just prior to the invasion of France, a station announcing that it was located in France and operated by patriots, turned up on 6040, 6270, and 7210 kHz. It was *La Voix de la Paix* (Voice of Peace). Programs in both English and French were attractively filled with popular French songs, but basically its message was to complain about the conduct of the French government. It said that it was leading the citizens into a war in which many innocent civilians would be killed.

The station outlined the awesome power of the German forces and itemized in very grizzly detail the "horrible death and destruction which the Third Reich has wrought throughout Europe." The Voice of Peace would sign off with emotional shouts of *Vive la France* and a rousing rendition of *La Marseilles*, the French national anthem.

British Intelligence determined that this station was located in Dusseldorf, Germany, and was a counterfeit — a clandestine operation of Goebbels' Ministry of Enlightenment and Propaganda. After the fall of France, The Voice of Peace was no longer needed and it was shut down—France had fallen in only six short weeks. Once in France, the Germans took over the main shortwave station, Paris Mondial, changed its name to Station Y, and incorporated it into its worldwide propaganda network.

Concurrently with the appearance of The Voice of Peace, and in anticipation of Hitler's planned invasion of Britain, a station known as The New English Broadcasting Station, supposedly run by "discontented British subjects," turned up on 7300, 9740, and 11960 kHz. Frequent half-hour length programs were presented throughout the day, opening with "Loch Lomond" and closing with "God Save The King." The station's primary programming consisted of "uncensored war news," and it was pointed out that should the station be "surpressed," others were ready to be placed in operation. This was another German undercover operation and it remained active throughout the Battle of Britain.

Black propaganda had been born! These stations became the inspiration for countless subsequent counterfeit stations supposedly operated by "patriots" and malcontents of one nation, but actually operated by intelligence agencies of other nations. One station that appeared more than ten years after WWII was Radio Free Hungary, which attracted world attention and sympathy in 1956 when the Russians sent their tanks into Budapest to put down a popular revolution that sought to overthrow the Communist regime. Radio Free Hungary's fervent pleas for help from the United States in the seemingly hopeless cause of the ragged Hungarian freedom fighters deeply touched the emotions of those in the free world. The terrors that the Russians were bringing to the Hungarian citizens were expounded in hideous detail and the Russians were cursed and denounced in every transmission.



NTS Free Russia was an underground propaganda broadcaster that knew the value of QSL cards to attract listeners. Despite the station's humble studios and transmitter facilities (located in a couple of trucks), NTS freely sent out cards to all who asked!

The station, it was later realized, was a totally brilliant fake operated by the Russian KGB with the intention of embarrassing the United States, since there was little chance that we would actually send troops to Hungary, even after our Radio Free Europe had spent many months suggesting that the United States would look with favor upon a popular uprising in Hungary. The Russians used Radio Free Hungary to play up the futility of trying to revolt against a Communist regime and the fact that America could not be relied upon for help in such a situation. It was so cleverly done that the nature of the station was not realized by our CIA until it had ceased operation and the revolution had been crushed. It was so effective that, to this very day, many Eastern Europeans remain suspicious of America's possible value in aiding popular revolts; it was even mentioned from the start of the current situation in Poland.

Radio Swan/Americas, as I mentioned earlier, was a covert CIA operation — one of the first to be cited as such by the media while it was still on the air. This doesn't mean that the 1960s station was the CIA's first experience in the area of black propaganda.

In 1954, the CIA had established two covert stations in the Middle East — The Voice of Justice and The Voice of Iraq. Supposedly, these were patriotic stations from within the Arab world which were decrying Nasser's rise to power in Egypt.

Also in 1954, the CIA's Radio Liberacion worked in cahoots with Colonel Carlos Castillo Armas to support his Honduran and Nicaraguan backed coup against the leftist regime of Jacobo Arbenz in Guatemala. Radio Liberacion openly incited officers in the

Guatemalan army to revolt against Arbenz; it gave exaggerated reports of anti-Arbenz military activities in Honduras, as well as fictionalized arms drops and border crossing data. The Armas coup was a military success—a propaganda triumph. Armas required only 450 men to topple the Arbenz government, and Radio Liberacion, which kept broadcasting during the nine day revolution, made the small invasion force appear as if it were a large, invincible war machine. The Guatemalans were duly impressed and intimidated—they barely fought back, keeping military casualties at a minimum.

As pointed out by author Harry Rositzke in his book *The CIA's Secret Operations* (Reader's Digest Press, 1977), "Propaganda operations are the easiest and least dangerous of all covert operations." Indeed, this is true; counterfeit broadcasters continually prove this. These days most clandestine stations that seem to be operated by "patriots" are immediately suspect as being hoaxes set up by the intelligence services of other nations. The lessons Goebbels taught were well learned.

The Legacy

Modern technology has permitted many refinements in the broadcasting of propaganda, while research into the workings of the human mind has enabled psychological warfare ("psywar") to be waged with far more subtlety, polish, finesse, and sneakiness than it was done 40 or more years ago. Essentially, however, modern day propaganda broadcasting's basic techniques and approaches have not substantially changed over the years. As distasteful as it seems, it does appear that it was Goebbels who first established guidelines and rules of the road for all of this, and it remains as his legacy.

Propaganda broadcasts, in their many guises and forms, still permeate the airwaves as nations of all sizes, ages, and political persuasions. They claw and elbow their way onto the crowded international broadcasting bands to peddle and hawk their beliefs, dogmas, likes, dislikes, annoyances, quarrels, aspirations, to brag about their successes and point out the failures of unfriendly nations.

Listeners are now plied with goodies,

DIPLOMA

Do you want to have this beautiful diploma to hang on the wall above your radioreceiver ?
 We are pleased to announce that Radio Bucharest will be awarding 1,000 diplomas, numbered from 1 - 1,000, to the first thousand of our listeners who will send us 12 reception reports, within 3 months. These reports should be numbered from 1 to 12 and marked "for the diploma". At the same time, we should like to let you know that our special broadcast for radioamateurs is on the air every Wednesday and Friday during our transmission at 1,30 GMT, that is 20.30 EST and 3 GMT that is 22 EST for North America and at 19.30 GMT and 22.30 GMT for Europe .

Radio Bucharest once offered this "beautiful diploma" to the first 1,000 loyal listeners who could prove that they had heard at least one of the station's Communist propaganda broadcasts per week for three months straight. A blatant enticement to get listeners into the habit of staying tuned.

If you like to make things work...and then find out why they work—

you could be getting paid for doing something you really enjoy!

Learn electronics...right on up to an Associate Degree...in your own home without giving up your present job or income.

People who really like their work get ahead faster. And, when your natural abilities match the job requirements, you have an extra advantage. When you use practical training to sharpen your skills, your odds are better for keeping your job even if others are losing theirs. So, if you find satisfaction and interest in making things work, a career in electronics may be for you.

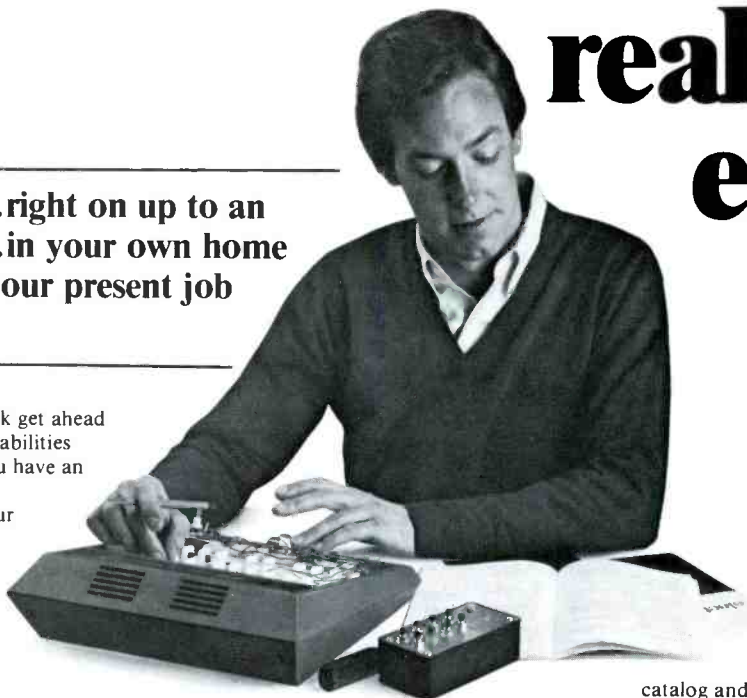

START MAKING THINGS WORK FOR YOU

Send today for the CIE school catalog and complete package of career information. It's all FREE, and it will help you decide where you want to start and how far you want to go. For your convenience, we'll try to have a school representative contact you to review the various educational programs and assist in course selection. Just mail the postage-paid card or write, mentioning the name and date of this magazine. We want to help you make things work, so send for your FREE school catalog today!

WHY ELECTRONICS IN THE 80's

Opportunity.

The field of electronics simply offers more career opportunities — and more job security — than most other fields today. Take digital technology, for example. Much of the new telecommunications, data processing, and production equipment depends upon sophisticated microprocessors to receive, sort, and send digital signals in micro-seconds. Two of CIE's newest home study courses combine digital electronics theory with actual experience on digital equipment. Successful completion of either one of those courses is creditable toward CIE's Associate Degree program. That's right... you can earn an Associate Degree without attending a single class session.

MAKING THINGS WORK

Many of CIE's Career Courses stress "hands-on" training. We believe textbook knowledge is important — but it's just as important to know to apply your book learning in practical situations. From basic circuitry in CIE's Personal Training Laboratory in several Career Courses, through the Microprocessor Training Laboratory, CIE helps channel your desire to "make things work" into skills you can sell.

IN A CLASS BY YOURSELF

One of the great benefits of home study is the independence it gives you. You study where and when you want to. You move as fast as you can handle it. There's no classroom to go to because with CIE, the classroom comes to you! But, you're never alone. When you request help, the CIE electronics expert best qualified will personally respond in writing.

SET YOUR OWN GOALS

CIE's wide selection of courses gives you many options. You start with a Career Course that suits your talents. Then, since more than half of CIE's courses include a series of optional lessons to prepare you to pass the government-administered FCC License exam, you can get an FCC License... a requirement for *some* electronics jobs and a credential for *all* electronics jobs. You may then go on and earn an Associate in Applied Science Degree in Electronics Engineering Technology. It's all up to you!

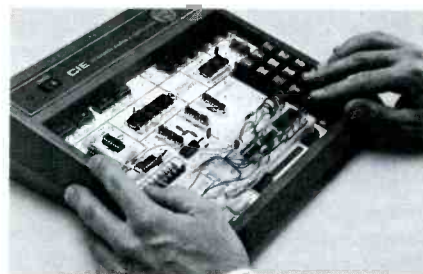

CIE's Microprocessor Training Laboratory, an integral part of the Associate Degree program, lets the advanced student apply digital technology in many of the same ways electronics professionals do.

CIE **Cleveland Institute of Electronics, Inc.**

1776 East 17th Street, Cleveland, Ohio 44114

Accredited School National Home Study Council



RADIO PRAHA MONITOR KLUB

splnil podmínky členství v celosvětovém krátkovlnném klubu Radia Prahy
 This is to certify that the holder of this certificate has qualified for membership in the RADIO PRAGUE WORLD WIDE SHORT WAVE CLUB

za současný výbor
 For the Award Committee
 Členské číslo
 Membership No.

W

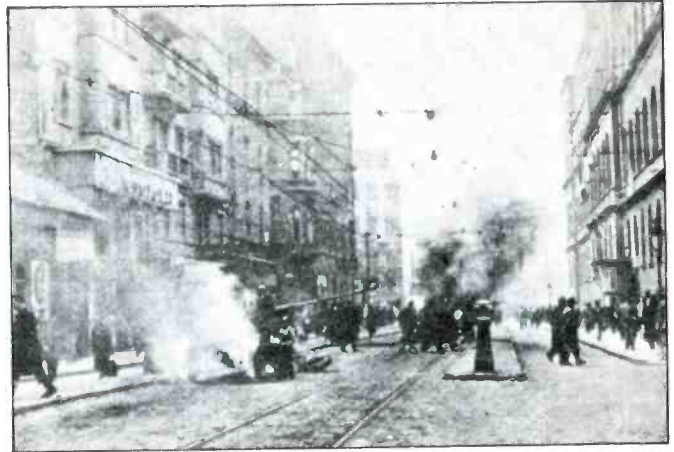
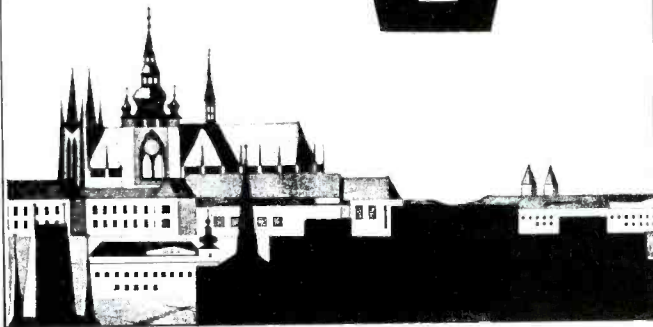

The ill-fated Hungarian Revolution is remembered graphically for scenes of vicious street fights and, later, Russian tanks. In this photo of October 28, 1956, when the freedom-fighters were succeeding, a Russian cannon is burning at left and another Red vehicle is affire in background. The scene is in Budapest. Less well known is radio propaganda war waged by the Russians, who identified themselves as Radio Free Hungary near the end of the revolt.

Radio Prague rewarded listeners tuned to its propaganda broadcasts with this handsome membership certificate in the station's World Wide Short Wave Club. Such enticements as this, or T-shirts, posters, and other souvenirs, are part of the standard trappings of propaganda broadcasters to build up good will and listener loyalty and credibility.

such as banners, decals, contests, awards, memberships, records, bumper stickers, T-shirts, program folios, photos, greeting cards, picture postcards, posters, and a myriad of other gifts to cultivate and retain their goodwill and listening allegiance in the hope that they will continue to accept what the station says as being truthful and worthwhile. Hopefully, they feel, listeners will concur with what the station says — out of philosophical agreement, dissatisfaction, confusion, fear, or even by the simple expediency of having the same message or theme (truthful or otherwise) repeatedly and relentlessly pounded into their consciousness.

Towards these ends, most major nations are armed with government-financed propaganda agencies and powerful broadcast transmitters operating around the clock. Some of these stations utilize nearly 100 different frequencies via 200,000 to 500,000 watt transmitters from primary and relay sites throughout the globe and it would be difficult for even the most casual listener to avoid hearing their messages.

While some major shortwave broadcasters still seem to disdain participating in hard-sell propaganda to any significant extent, in most instances the programming listeners encounter in shortwave from major world powers (and their close allies) is carefully

prepared by experts to produce a desired psychological reaction in listeners. That long or short term effect is to tip the delicately balanced scales of public opinion towards the originating nation — be it to incite the overthrow of an unfriendly government, to affect the outcome of an election, to cause discouragement in enemies and confidence in its own citizens and its allies, to promote or put down a political philosophy, to justify or complain about military action, etc.

Keep these things in mind as you tune across a shortwave band. Listen to the content of the programming with an ear towards picking out and understanding some of the tried-and-proven old propaganda tricks and stunts in use. You may then come to realize that you — yes, you, there at your receiver with your ability to form opinions based upon what you hear — are highly prized and esteemed by world broadcasters. And while you may have always felt that you've zeroed in on a particular station, you may now realize that it is you who has been zeroed in upon and you're directly in the line of fire.

The idea is to realize this, see it for what it is, know how it works, and never cease to react with wonderment that you're sitting right in the midst of a very real battlefield in which a fierce and unending war of words and ideas is being waged.

The 6 Kinds of Propaganda

- 1. Propaganda Of Terrorism.** Its aim is to break down the morale of those in enemy countries by threats and vivid descriptions of the consequences of enemy attack. Recent victories against other enemies are itemized to further soften the target audience. It gives confidence to nations that are allied with the propagandist, and frightening those in neutral nations in order to keep them neutral.
- 2. Propaganda Of Paralysis.** Its goal is to keep the enemy inactive by dividing sentiment and preventing the people from reaching any united decisions or acting in a cooperative manner with one another.
- 3. Propaganda Of Division.** Seeks to drive a wedge between the enemy nation and its allies and friends by emphasizing frictions and divisions of the past.
- 4. Propaganda Of Dissention.** The aim is to cause ill feeling in the enemy country by pitting its citizens against one another based upon their race, religion, national origin, politics, economic status, job, etc.
- 5. Propaganda Of Confusion.** Attempts to prevent prompt action by public officials by bewildering them with various hints pointing in different directions.
- 6. Propaganda Of Variety.** By giving a large number of explanations and arguments for the actions of the nation presenting the propaganda, it seeks to convince everyone. Those who reject one explanation may accept another.

Cordless Phones: How Far Can You Talk?

Increased Cordless Phone Range – Yes, But!



This is the Model 636 Cordless Phone Antenna (new for 1983).

The cordless phones have captured the interest of the American public, second only to video games in 1982. This new electronic marvel allows you to roam over the house, yard, and with an external antenna system, over the whole neighborhood and still maintain phone contact through your own phone service. The new cordless phones are coming through with many features, such as: memory radials, intercoms, and hold positions. Their size and weight have been reduced to a minimum.

Now that we have covered what the cordless phone will do for you, let's explain some of the problems that you may or may not encounter with using and increasing the range of a cordless phone system. The basic range of cordless phones is from 100 feet to 700 feet. They generally fall into two range categories: 100 to 200 feet and 500 to 700 feet.

Increasing the range of a cordless phone system is quite feasible with an external antenna system. This antenna system, however, is quite complex. The reason for the complexity is due to the frequency assignments. The base unit transmits on a frequency of 1.7 MHz (just above the AM broadcast band). The portable phone transmits on 49

MHz (just below TV channel 2 and the 6 meter Ham band. The power level of both units are quite low, thereby reducing range.

The attempt at controlling the range is quite necessary since there are at present only five channels assigned for cordless phones. If you think CB was bad with 23 or even 40 channels, you haven't seen anything yet. Can you imagine a 100 unit apartment project with only five telephone lines? Some of the more deluxe units use guard tones to reduce the interference from other units. Even so, you still have only five channels to talk on.

Even with these limitations, there are many applications for range enhancement with an external antenna system. Examples: the small farm, construction sites, large estates, lumber yards, auto dealerships, lake houses, beach houses, etc.

The cordless phone antennas presently come primarily from three leading companies: Winn-Tenna, Inc., Firestick, and Valor. Winn-Tenna offers three different models. Firestick and Valor each offer a single model for domestic use. All three firms offer several export models at special export frequencies. Foreign users have a major advantage over U.S. citizens in that they are allowed higher power and better frequencies. Their systems give up to 20 miles or more.

The antenna systems for cordless phones are actually two separate antennas. The simplest is the 49 MHz antenna, which usually comes with 40 or 50 feet of coax cable. This antenna is usually a simple dipole or ground plane construction and is about nine feet tall. Winn-Tenna offers an additional horizontal polarized dipole in one of its models. The installation of the 49 MHz antenna is usually as simple as installing a TV, scanner, or small CB antenna. TV telescopic mast is quite suitable for mounting. The usual precautions should be observed in keeping the antenna away from other metal objects. The higher the better!

Remember. Caution should be observed when working near power lines with any antenna system.

The coax cable can be attached internally at the appropriate point; technical work will be needed here. Winn-Tenna and Valor offer an adapter system that eliminates the need for soldering and wiring-in the cordless phone antenna connection. These adapters come with the proper fittings for connecting the antennas without technical assistance and are well worth the cost.

The more difficult antenna installation will be the long wire antenna. The long wire antenna is the one that transmits from the base unit to the portable unit, so you know its not working when you can be heard but you can't hear.

The long wire antenna should be installed as vertical as possible and must be free from close proximity to other metal objects, such as towers, wires, mast, metal buildings, roofs, and power lines. Avoid long parallel runs to any metal objects. Observing these precautions, additional range can be achieved on the order of two-to-three times the original range.



A DX'ers New Year's

BY GERRY L. DEXTER

What are you doing New Year's Eve? The usual parties and football games? Why not try something really different during the changeover from 1982 to 1983? Celebrate the New Year with your shortwave receiver! You'll enjoy a multi New Year's Eve celebration instead of just one, and have an excuse to lift more than one glass of the bubbly! It'll also be a good test of your stamina!

If you're game to try, it's a good idea to start planning for this special shortwave event now. In the summary that follows, we've tried to project what stations and frequencies will provide you with your best chance for reception hour by hour. But, as we continually stress, the shortwave picture is a constantly changing one—so you may want to spend some time off and on for a week or so in double checking and spotting your targets ahead of time.

Another possibility would be sending reception reports on all your New Year's Eve loggings. QSLs showing date and time might make a unique display.

So, get a good night's sleep the night before. Make sure you have plenty of coffee on hand and get ready.

1200 GMT: December 31st on the East Coast, and the first New Year celebration to occur is in New Zealand. At this writing, there's still doubt as to whether Radio New Zealand will be in operation at all. To make things even chancier, 1200 is past normal sign off time. We're hoping the station will still be operational and perhaps stay on til at least 1200. Try 9.540, 11.945, 15.485, or 17.705. If you draw a blank, another possibility is FR4, Noumea, New Caledonia on 7.170 in French.

1300 GMT: About your only chance is a Russian transmitter site at Petropavlovsk. Try 4.485, though it may not be on at that time, or audible if it is.

1400 GMT: This brings the New Year to Eastern Australia, so tune one of Radio Australia's Overseas Service frequencies, such as 9.580, 5.995, or 11.770.

1500 GMT: Be ready for Radio Japan (NHK) on one of their many overseas service frequencies, including 9.505, 9.645, or 11.815.

1600 GMT: You can go back to Australia, this time to the other side of the continent and VLW9 at Perth on 9.610. Or, do

your celebrating in Manila with the Voice of the Philippines on 9.580.

1630 GMT: Some of the countries located half-way between two time zone borders make a compromise by half an hour. Indeed, there are even a few which are 15 or 45 minutes ahead or behind! But anyway, at 1630 it's midnight in Malaysia and perhaps Radio Malaysia will be making it through on 9.750 or 15.295.

1700 GMT: This brings the New Year to Peking. Reception of this one may be rather difficult except on the West Coast. But, check one of Radio Peking's frequencies such as 11.600, 11.655, 15.100, or 17.800, among many others.

1800 GMT: This is a virtual impossibility. They are raising glasses of yak's milk in Lhasa. But, take a stab at Tibet on 9.490.

1830 GMT: Equals midnight in India, so try one of all India radio's frequencies including 15.185, 11.620, or 9.912.

1900 GMT: They should be carousing in Karachi now. This one will be difficult to catch. Try 9.425, 11.670, or 15.500.

1930 GMT: Means it's time to try Afghanistan on 15.077 or 9.665.

2000 GMT: You've earned yourself a break. Besides, there are no targets available at this hour.

2030 GMT: It's 1983 in Iran and the Voice of the Islamic Republic of Iran should be an easy catch on 15.084.

2100 GMT: And it's midnight in Moscow. The North American service isn't on the air yet, but the World Service is going strong on a great number of frequencies. This is a good example of a case where pre-tuning can help.

2200 GMT: You can try Cairo, Egypt on 15.375, which is supposed to have English at this hour. If not, try the French service on 15.335. You might have better luck with South Africa and Radio RSA, scheduled to 2157 with a three minute break before resuming programming; try 9.585, 11.900, or 17.795.

2300 GMT: And it's off to Europe. Check for Vienna on 9.770 or Rome on 9.575, 9.710, 11.905, or 15.245. Or, go after Swiss Radio International in Portuguese on 11.950 or German on 15.305. There are a lot of countries to choose from at this hour.

0000 GMT: Where else but London? The BBC World Service can be found on many frequencies, probably including 9.410, 9.510, 9.580, 9.825, 11.750, 15.070, and others.

0100 GMT: Not much hope at this hour. Cape Verde Islands are about your only chance and normally they aren't on now. But, it's possible they could be on an extended schedule for the occasion, so give 3.930 a try—although you can expect reception to be extremely difficult.

0200 GMT: It's break time again. Make a fresh pot of coffee and do a few sit-ups!

0300 GMT: Radiobras in Brazil should be "samba-ing" its way into 1983. Try 11.780, 15.245, 15.280, or 15.290.

0330 GMT: Another half-way country is Surinam. It should be fairly easy to pick up Radio Apinte from Paramaribo on either 4.996 or 5.005—they seem to bounce back and forth from one to the other.

0400 GMT: And back to Brazil we go for Radio Bare on 4.895 from Manaus on the Amazon River.

0500 GMT: The first New Year's celebration in America. But no fair cheating by tuning your local broadcast band stations now that the home folks are finally getting around to celebrating. Try HCJB in Quito, Ecuador on 9.745 or 11.915; or Havana on 11.760.

0600 GMT: Try XEWW, La Voz de l'America Latina from Mexico City on 9.515. Or perhaps Radio Mexico may run late. Check 9.705 or 11.770 just in case.

0700 GMT: There are no possibilities at this hour. Yawn!

0800 GMT: The best you can do is KGEI from California. They should be on in Spanish on 9.615.

0900 GMT: Another empty hour. But take heart—you've almost made it!

1000 GMT: The best you can do is try to hear the National Bureau of Standards station WWVH in Hawaii. It's often audible be-

hind its' sister station, WWV. Unfortunately, you won't hear local time announced. 5.000, 10.000, 15.000.

1100 GMT: The day ends with something of a whimper. In fact, total silence since there are no possibilities at this hour.

New Year's on shortwave has other possibilities, too. Many stations feature special programming during their regular schedules (not necessarily at local midnight) and others, especially the commercial Latin American stations, will run late or even all night.

Make it a point to catch the North American Service of Radio Peking. In past years, they've put aside their normal, straightlaced programming and run a very loose, informal program. Try from 0000 on 15.120, 17.680, or 17.855.

Radio RSA from South Africa has, in past years, featured a worldwide call-in program, taking live telephone calls from listeners in all parts of the world, making for very interesting listening. Try 0200-0400 on 5.980, 9.580, 11.900, or 15.325.

Radio Moscow's North American Service from 2300 to 0500 often features greetings to listeners who have written to the station in the past year. It's interesting listening.

But, whether you spend that 24 hours at the receiver or just do some casual listening before you head out for the big New Year's Eve bash, it's very likely you'll find at least one station that'll catch your ear as the world bids goodbye to 1982 and welcomes 1983. Happy New Year!

SCANNER CRYSTALS!

America's leading mail-order supplier!

Let Z-Tech Enterprises be your prime source of precision scanner crystals. We are specialists in crystals for federal frequencies, public safety, aero band, business/industrial, maritime. Shipped to you factory fresh and ready to zero in on the stations you want to hear. Low prices, too! We'll be pleased to send you our special order form offering the best prices you've ever seen for precision custom-cut scanner crystals. Just ask us for it!

Z-TECH ENTERPRISES
P.O. Box 70 Hauppauge, NY 11788

WT



CORDLESS PHONE

"RANGE EXTENDO" ANTENNA

MODEL 636

Now increased range can be had with your cordless phone. Super "Range Extendo" antenna with plug and clip adapter for easy installation.

No soldering or cover removal on your cordless phone required. Will not void warranty.

Horizontal polarized antenna increases range over 300% while reducing man made noise. Allows for natural position of hand held phone unit.

Write or call for our complete catalog of CB, Scanner, Ham, Mobile T.V. Antennas and Accessories.

WINN-TENNA, INC.

911 AMITY ROAD
ANDERSON, S.C. 29621
803-261-3965
800-845-9724

POP'COMM Intelligence Report:

San Francisco Police Department

Here's Their Communications System & Radio Codes!

The San Francisco Police Department seems to get itself into our daily news media with an uncanny regularity—a factor of being a leading metropolitan area and having a particularly colorful and efficient police department. This month, we thought that we would offer you a breakdown of this interesting city's police communications system.

Our information this month was submitted by Carl Silva, Registered Monitor KCA6KE, who hails from (you guessed it, didn't you?) that city by the Golden Gate. Carl's information shows the identifications used by the individual radio units, the currently authorized operating frequencies and callsigns, the radio codes, 10-codes, and even the commonly encountered abbreviations used by the SFPD.

We are interested in receiving additional information from our readers relating to various state agencies, major city agencies, agencies in larger counties, etc. If you prefer that we not mention your name when we run the information, please let us know.



San Francisco Police Department

Callsign: KMA438 (Additional callsigns: KNL512, KCC838, KLG596, KLV960, KMJ408, KMJ409, KMJ410, KMJ412, KMJ413, KMJ414, KMJ415, KMJ417).

Authorized Frequencies: 45.10, 45.14, 45.30, 45.46, 45.58, 155.55, 155.67, 460.075, 460.225, 460.35, 460.50, 462.95, 462.975, 488.8125. Note: 45.30 is for mobile units only; 155.55 is for Narcotics, Vice, Juvenile, and Intelligence; 155.67 is for inter-system use.

Radio Unit Identifications

Division 1 Headquarters

1-Adam 1 to 20	Chief's Office
1-Adam 75 to 80	Public Affairs Office
1-Boy 1 to 10	Commissioner's Office
1-Charles 1 and 2	Mayor's Office
1-Charles 25 to 35	Chaplains
1-Charles 36	Ambulance Chaplain
1-Charles 37	Chief Admin. Officer
1-Charles 80 to 89	Coroner's Office
1-David 1 and 2	District Attorney's Office
1-Edward 60	Emergency Services Van
1-Edward 61 and 62	Director/Asst. Dir. Emerg. Svcs.
1-Edward 63 to 69	Emerg. Services Staff Units
1-Frank 1	Internal Affairs, Commanding Officer
1-Frank 2 to 99	Internal Affairs Units
1-George 1	Staff Inspection Officer
1-George 2 to 49	Staff Inspection Units
1-Henry 1 to 49	PD Legal Office Units
1-John 1 to 99	Juvenile Bureau
1-Lincoln 1 to 99	Community Relations Bureau
1-Nora 1 to 99	Narcotics Bureau
1-Paul 1 to 99	Intelligence Unit
1-Sam 1 to 99	Bureau of Special Services

Division 1 Staff & Services

2-Adam 1	Admin. Bureau (Secretary)
2-Adam 2	General Office
2-Adam 5	Cab Detail
2-Adam 10	Permit Bureau
2-Boy 1	Director of Personnel
2-Boy 5	Project Diversion
2-Boy 10 to 19	Personnel Bureau Staff

2-Boy 27
2-Boy 30
2-Boy 40 to 69
2-Boy 70 to 79
2-Boy 80
2-Charles 1 to 99
2-David 1 to 49
2-Edward 1
2-Edward 2
2-Edward 22 to 49
2-Frank 1 to 19
2-Frank 20 to 29
2-Frank 30 to 39
2-Frank 40 to 49
2-Frank 50 to 79

Division 3 Patrol

3-Adam 1 to 316
3-Adam 1 to 29
3-Adam 30 to 32
3-Adam 35 to 38
3-Adam 41 to 59
3-Adam 60
3-Adam 61 to 63
3-Adam 65 and 66
3-Adam 70
3-Adam 80 to 89
3-Adam 90 to 99
3-Adam 301 and 303
3-Adam 315 and 316
3-Boy 1 to 316
3-Charles 1 to 316
3-David 1 to 316

AA Officer
Visiting Sick Sergeant
Police Academy Units
Range Units
Psych. Officer
Planning & Research Units
Property Clerk
Insp. Motor Vehicles
Garage Pick-up Truck
Tow Truck & Misc. Garage Units
Bureau Crim. Info. Director's Staff
BCI—Communications Units
BCI—Identification Units
BCI—Records Bureau
BCI—Wants & Warrants

Central District Units
Basic Patrol Units
Wagons
Burglary/Robbery Detail
Foot Patrol Beats
Radio Car Sergeant
Section Sergeants
Sta. or Dist. Lieutenants
C.O. District Capt.
Patrol Special Officers
Squads of Tactical Duty
Sworn Personnel
Civilian Personnel
Southern District Units
Southeast District Units
Mission District Units

3-Edward 1 to 316 Northern District Units
 3-Frank 1 to 316 Park District Units
 3-George 1 to 316 Richmond District Units
 3-Henry 1 to 316 Ingleside District Units
 3-Ida 1 to 316 Taraval District Units
 (3-Boy to 3-Ida stations would have the same specific unit assignments as shown for 3-Adam stations.)
 3-Paul 1 to 10 Patrol Bureau
 3-Queen 1 City Prison
 3-Tom 1 to 99 Crime Prevention Units
 3-Victor 1 to 40 Helicopters
 3-Xray 1 to 49 Harbor Police
 3-Zebra 1 to 49 Housing Police

Division 4 Traffic

4-Adam 1 and 2 Dir. & Capt. of Traffic
 4-Adam 3 and 4 Traffic Education Unit
 4-Adam 5 Court Officer YGC
 4-Adam 6 Traffic Survey Unit
 4-Adam 7 to 11 School Safety Patrols
 4-Adam 12 Out-of-State Unit
 4-Adam 13 Parking Meters
 4-Adam 14 Impounds
 4-Adam 15 and 16 Safety Officers
 4-Adam 17 Maintenance Officer
 4-Boy 1 to 79 Solo Motorcycle Patrols
 4-Boy 80 Motorcycle Platoon Cmdr.
 4-Boy 81 to 89 Motorcycle Sergeants
 4-Boy 90 to 99 Motorcycle Training Units

4-Charles 11 to 22 Accident Investig. Units
 4-Charles 30 Accident Investig. Sgt.
 4-Charles 50 E & I Division
 4-David 10 Hit & Run Civ., C.O.
 4-David 41 to 45 Hit & Run Units
 4-Edward 1 to 10 Congest. & Pkg. Sgts.
 4-Edward 11 to 30 C & P Area Units
 4-Edward 40 C & P, Crndg. Officer
 4-Frank 1 to 150 Civ. Parking Cntrl. Units
 4-George 200 to 250 Civ. Traffic Cntrl. Units
 4-Henry 80 to 89 Ambulances

Division 5 Inspectors' Bureau

5-Adam 1 and 2 Chief/Capt. if Inspectors
 5-Adam 3 to 99 Inspectors' Night Crew
 5-Boy 1 Criminalist/Crime Lab
 5-Boy 2 to 49 Crime Lab Units
 5-Boy 50 to 99 Photo Lab Units
 5-Charles 1 to 99 Auto Detail
 5-David 1 to 99 Burglary Detail
 5-Edward 1 to 99 Pawn Shop Detail
 5-Frank 1 to 99 Fraud Detail
 5-George 1 to 99 General Works Detail
 5-Henry 1 to 99 Homicide Detail
 5-Ida 1 to 99 Missing Pers./Sex Detail
 5-John 1 to 99 Robbery Detail

An "S" at the end of any unit means a solo (1 officer) unit. For instance, a unit identifying as 4-Charles 11 Sam is a single-officer Accident Investigation field unit.

San Francisco Police Department Radio Codes

Complaints

100 Burglar Alarm
 100S Silent Burglar Alarm
 102 Drunk Driver
 187 Murder
 211 Robbery (Holdup)
 212 Strongarm
 213 Pursesnatch
 217 Shooting
 219 Cutting
 221 Man With Gun
 240 Assault
 245 Assault/Deadly Weapon
 261 Rape
 288 Crimes Against Children
 311 Indecent Exposure
 400 Evacuation/Mobilization
 404 Riot
 405 Citizen Holding Prisoner
 406 Officer Needs Assistance
 407 Send Wagon
 408 Send Ambulance
 409 Send Tow
 410 Requested Assist. Responding
 415 Noise Complaint
 417 Man Ringing Doorbells/Begging
 419 Serious Disturbance (Felony)
 420 Juvenile Disturbance
 459 Burglary
 487 Grand Theft
 488 Petty Theft
 518 Auto Accident (Prop. Damage)
 (H&R = Hit/Run)
 519 Auto Accident (Pers. Injury)
 (H&R = Hit/Run)
 520 Accident (No Auto)
 527 Bonfire
 528 Fire
 529 Explosion
 530 Bomb Threat
 585 Traffic Stop
 586 Traffic Congestion
 587 Tag Improperly Parked Auto
 596 Abandoned Auto
 600 Roadblock
 602 Breaking & Entering

603 Prowler
 800 Alleged Insane Person
 801 Attempted Suicide
 802 Coroner's Case
 805 Juvenile Complaint (Minor)
 811 Drunk Case
 819 Drunk Rolling
 851 Stolen Auto
 852 Tampering With Auto
 901 Call _____
 902 Return To Station
 903 Close Signal Box
 904 Meet An Officer
 905 Meet A Civilian
 909 Interview A Citizen
 911 Broken Window
 912 Person Dumping Rubbish
 913 Complaint Unknown
 914 Person Down
 916 Investigate Men In Auto
 917 Investigate Suspicious Men
 918 Person Screaming For Help
 1000 Plane Crash
 2000 Prison Break
 3000 Blockade
 (An "X" on any call means a woman is involved)

Codes

CODE 1 Handle At Your Convenience
 CODE 2 URGENT Respond Immediately
 CODE 3 EMERGENCY Use Red Light & Siren
 CODE 4 No Further Assistance Required, Situation Under Control
 CODE 33 Clear All Channels for EMERGENCY Call From A Mobile Unit

Ten Codes

10-1 Receiving Poorly
 10-2 Receiving Well
 10-4 OK/Message Received
 10-7 Out Of Service
 10-7G Out of Service/Garage
 10-7M Out of Service/Meals
 10-8 In Service
 10-8F In Service, On Foot

10-9 Repeat Last Message
 10-13 Advise Conditions at Scene
 10-22 Cancel Last Assignment
 10-23 Standby For A Few Moments
 10-25 Respond & Act as Backup Unit
 10-28 File Check For Auto Registration Info
 10-29 File Check For Wanted Person/Auto
 10-30 Person/Auto is Wanted/Stolen
 10-31 Person Has Record. Not Wanted Now
 10-32 Person/Auto Clear At This Time
 10-35 Person On Parole Under Following Conditions:
 10-96 Leaving Vehicle To Investigate Suspicious Situation; If Not Heard From In 5 Min. Send Another Unit
 10-97 Arrived At Scene
 10-98 Continuing To Another Location

The Code word RED used with a 10-30 or 10-31 Indicates A Felony Want Or Felony Record.

Abbreviations

CABLE Computer Assisted Bay Area Law Enforcement
 CEH Central Emergency Hospital
 CLETS Calif. Law Enforcement Teletype System
 CWB Central Warrants Bureau
 HANDCHECK Checking Files By Hand
 MEH Mission Emergency Hospital
 NCIC National Criminal Info Center
 PIC Walkie Talkie
 PIN Police Information Network
 ROLLER A Moving Vehicle Being Following By PD
 SFGH San Francisco General Hospital
 SF NUMBER A Number Assigned To Anyone With A San Francisco Criminal Record
 VIN Vehicle ID Number (Serial #)
 X A Female

The Continuing "Numbers" Stations Mystery

BY HARRY L. HELMS, KR2H

If you've done much tuning on the short-wave bands late at night, you've probably run across a woman's voice, in Spanish, mechanically reciting a stream of numbers like this . . . "uno, cinco, siete, cero, cinco . . . tres, ocho, cinco, cinco, cero . . ." until she abruptly ends the message with "final, final." Just what are these messages?

Listeners have been debating (and arguing) that question since the early 1960s. Some people feel they are actually coded messages to spies in the field. Others have speculated they are on-the-air "training classes" for prospective agents. Another theory is that they are part of various schemes to divert the attention of casual listeners away from other, more important types of communications activity.

What we do know is that such "numbers" stations are still with us after 20 years. And they are perhaps the most baffling activity upon which listeners with average equipment and skill can eavesdrop.

Hearing "numbers" stations is actually quite easy. In fact, if you tune the 3000 to 12000 kHz range any night from 0200 to 1000 GMT, you'll probably hear several. The most common type transmits five digit groups in Spanish using a female announcer. But, you'll also hear English and German used, along with a smattering of other languages. Sometimes, the transmissions use four digit groups. Most transmissions are AM, but some are in SSB or even CW.

More is known about the five digit Spanish stations largely because they are the most commonly heard. Transmissions from these stations follow a well-established pattern. Each transmission opens with an identifier consisting of the word "atencion" (attention), followed by a pair of two- or three-digit numbers, as in "atencion 010 86." The first number group following "atencion" is believed to be the "addressee" the message is intended for. (However, some believe it to be the identifier for the key used to decode the message.) The second number group following "atencion" is the number of five digit groups in the message. In our example, the message itself would consist of 86 five-digit number groups. The identifier is repeated for several minutes before the start of the actual message.

The message itself is the five digit groups read by a woman in a very "mechanical," emotionless voice. If you listen carefully, you'd notice that the digits sound alike throughout the message. That's because each message is made up from a pre-recorded set of digits, much like those recordings used by the telephone company to give out changed telephone numbers. After the end of the five digit groups, the message abruptly ends with "final, final," which is idiomatic Spanish for "that's all."

As previously stated, you're likely to hear "numbers" stations of the five digit variety almost anywhere late at night from 3000 through 12000 kHz. However, certain ranges are "hotter" than others for this type

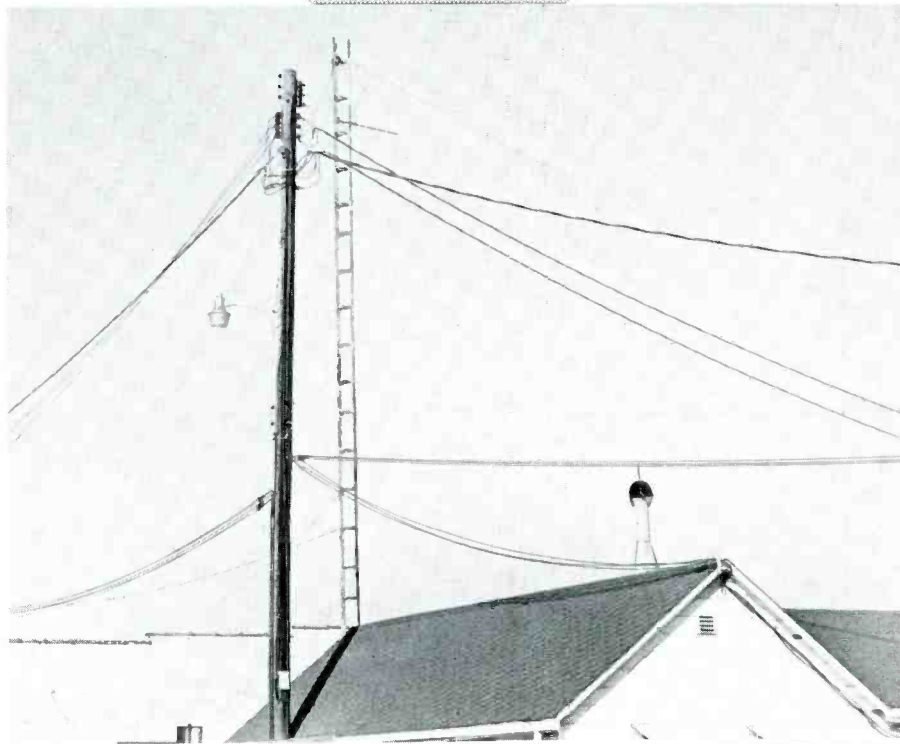

of activity. Here's a guide to the frequencies and times (in GMT) to particularly check:

Frequencies	Times
3200-3400	0200-0500
3800-3900	0300-0430
4300-4700	0300-0730
6700-6900	0600-0900
7300-7500	0230-0700
7800-8150	0300-0600

In addition, the frequencies of 3060 and 3090 kHz have been used for five digit transmissions for several years during the early evening hours.

Much more elusive are Spanish "numbers" stations using four digit number groups. You may find yourself catching one four-digit station for every ten five-digit stations you hear—the four digit stations are that rare.

You'll also hear "numbers" stations in English and German from time to time. These pop up in the same frequency ranges where Spanish stations are heard, but they are usually heard in the 2000-0300 time period. The five digit stations predominate in English and German, although you may catch an occasional four digit transmission.

There are some clear differences between the Spanish "numbers" stations and their English and German counterparts. The signals from the English and German stations are usually weaker than those from the Spanish stations. The English and German stations are more likely to use SSB. And German stations are prone to begin transmissions with various sounds, such as guitar music or electronic tones.

"Numbers" stations have also been heard in French, Arabic, Czech, and Serbo-Croatian. However, these are relatively rare.

"Numbers" transmissions are also made in Morse code. These messages stand out because they are in AM with the Morse code produced by a keyed audio oscillator! Most messages consist of groups of five letters and digits. Each transmission opens and closes with a series of three "dahs" (TTT TTT TTT). Signal strength, frequency ranges, and times of operation are the same for the Spanish stations.

A major question—where are the "numbers" stations located? From the signal strength and propagational patterns, it seems clear the English, German, and other non-Spanish language stations transmit from somewhere in Europe. The Spanish and Morse code stations transmit much closer to North America—perhaps from the United States itself!

For many years, Cuba was considered the most likely source for these transmissions. The "numbers" stations began in the early 1960s shortly after Fidel Castro aligned Cuba with the Soviet Union. There were scattered reports that some Spanish "numbers" transmissions were heard opening with the interval signal of Radio Havana Cuba. In 1975, several listeners reported hearing audio from Radio Havana Cuba in the background of the Spanish "numbers" stations, indicating both shared a common

transmitter site and audio from the two were getting mixed together. And, in 1978, a listener wrote the FCC and asked about the location of a five digit station he'd heard on 3090 kHz. The FCC said direction-finding efforts had placed the station in Cuba.

However, there is much evidence pointing to locations in the United States. Sometimes English and German "numbers" messages have been heard in the dead air following the end of a Spanish "numbers" transmission. This could mean that all "numbers" transmissions originate from a single "studio," and Cuba would be unlikely to be transmitting messages in Czech from a European location. Spanish stations are often extremely powerful. Listeners in such diverse areas as southern Florida, Washington, D.C., Ohio, and Oregon have noted solid, fade-free reception of numbers stations, which would be impossible if the stations were in Cuba.

One listener in southern Florida drove around in his car with a portable receiver tuned to a "numbers" station. In several locations, the receiver overloaded. This meant the transmitter had to be quite close—perhaps a few thousand feet or less. Finally, several listeners equipped with directional receiving antennas cooperated in making direction-finding measurements. Their evidence places the locations of these stations on the Gulf Coast of Florida, near Portland, Oregon, in Puerto Rico, and near the Guantanamo Naval Base in Cuba.

So who is responsible for these transmissions? It is very tempting to conclude that some agency of the United States government is, but that does not automatically exclude the possibility that some of the transmissions could be originating from Cuba. It could well be that both the United States and Cuba are the sources for these messages, perhaps even engaged in an on-the-air game of double-cross as they try to mislead each other's agents!

But are these transmissions really related to espionage? It has been discovered that some of the five digit transmissions are repeated—word for word and number for number—several days, weeks, and even months apart from their first transmission! Moreover, such repetition occurs within the same general time period, frequency range, and even day of the week.

The five digit transmissions are less technically sophisticated than the four digit transmissions. (Often, there is a distinctive "hum" in the background of the five digit station audio.) The clues linking the "numbers" stations to Cuba (such as the Radio Havana Cuba audio) are found only on the five digit stations. And the five digit transmissions are much more numerous—almost as if they were trying to call attention to themselves! One theory has it that the five digit messages are for training, or as a "smoke screen," while the four digit transmissions are the actual messages to spies in the field.

Whatever they are and wherever they're from, few listening experiences beat keeping track of "numbers" activity.

Don't Be Left Out in the Cold with the Russian Woodpecker

GET A MOSCOW MUFFLER™

Another first from AEA. The Woodpecker Blanker, WB-1 really works. This unit effectively blanks the pulsing interference of the Russian Woodpecker. Two versions are available, the WB-1 for use with communication receivers and WB-1C for use with all popular transceivers.



This extremely useful accessory is designed for direct insertion between your receiver (or transceiver) and the antenna. It is both MORE EFFECTIVE than I.F. type blankers and requires NO MODIFICATIONS to your receiver! The unit operates from a 13 VDC \pm 2 VDC power source at less than 575 mA. (AEA AC wall unit AC-1 will operate the blanker.)

The blanker works well on both CW and SSB modes that are being interfered with by a woodpecker. Controls on the front panel include; four push button switches, a synchronize control and a width control. The WB-1 also features a low-noise untuned broadbanded 6 db gain pre-amp which can be selected with or without the blanker enabled. The WB-1C uses the same circuitry but includes a carrier operated relay (COR). This provides protection to the receiver section during transmissions from the attached transceiver.

For more details, write for our latest catalog or visit your favorite dealer.

Prices and Specifications subject to change without notice or obligation.

ADVANCED ELECTRONIC APPLICATIONS, INC.

P.O. Box C-2160,
Lynnwood, WA 98036
(206) 775-7373

Telex: 152571 AEA INTL

AEA Brings you the Breakthrough!

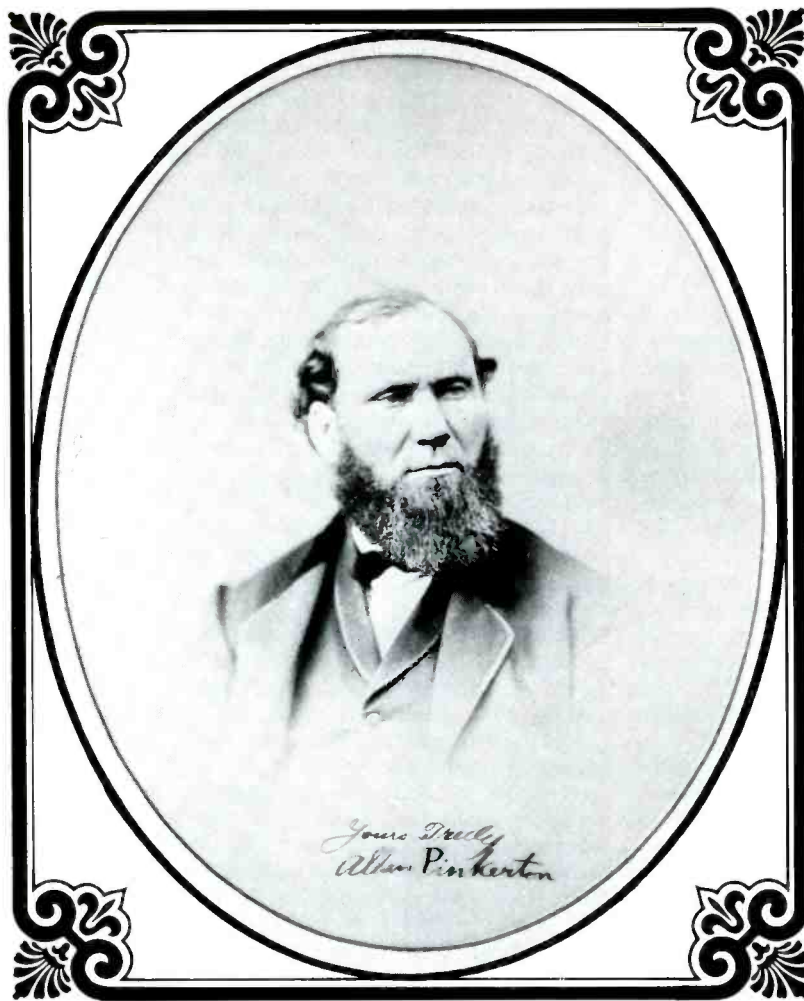

Tune In The Pinkerton Men

The Original "Private Eyes" BY RICK MASLAU, KNY2GL

Bewhiskered Allan Pinkerton, in 1850 (when he was 31 years old), established one of the very earliest detective agencies in the United States. Not long after his agency was formed, he cracked a large counterfeiting ring; from that time on, his name appeared regularly in the newspapers of the day. By 1861, his agency was hired by the federal government to guard Abraham Lincoln as he journeyed from Illinois to the nation's capital to be inaugurated.

Not long after the Civil War began, the government again called upon Allan Pinkerton—this time to help organize the Secret Service and even become the agency's chief. Simultaneously, he continued to operate his own Chicago-based detective bureau, which had started to open offices in other cities. The reputation of Pinkerton's agents continued to increase and by the end of the Civil War, "Pinkerton Men" were regularly hired out to many companies—most of their duties at that time being connected with breaking the many labor strikes that broke out during the Reconstruction years. In fact, since the Pinkerton men were employed by management, and had proven so effective, union members grew to dislike them with a passion.

Pinkerton's men were active in many fields, and starting with the capture, in 1868, of the notorious Reno Brothers' gang, the agency became the scourge of bank and train robbers. Certainly, the Pinkerton Men earned their place in the history books on the Old West; there's hardly a six-gun saga ever to emerge from Hollywood that doesn't mention them.

Allan Pinkerton not only later became deputy sheriff of Kane and Cook Counties in Illinois, his Pinkerton Men belong to an organization that still continues to this very day as one of the largest and most important private detective agencies in the entire world. Pinkerton died in 1884 at the age of 65.

Amongst the duties carried out by modern day Pinkerton security officers are those of guarding and patrolling many energy-related industrial installations (nukes and other power plants), coal mines, oil refineries, etc. Pinkerton offers complete security services to these and other installations. Here is the Pinkerton's communications system:

The Pinkerton's Network

AK	(portable)	WZJ619	464.55
AZ	Litchfield	KSS639	461.95
	Phoenix	WDC906	461.95
		KH8890	461.95
AR	Little Rock	KSV224	151.745
CA	Dulzura	AAA8223	462.55
	San Diego	AAA8224	462.55
		AAA8225	462.55
	San Francisco	KNP524	484.0875
		WBL700	484.0875
		KW8171	484.0875
	San Mateo	KZG382	484.0875

SWL HEADQUARTERS

ELECTRONIC EQUIPMENT BANK THE NAME IN SHORTWAVE LISTENING

INFO-TECH

ONLY \$378 ZENITH MONITOR
Reg. \$478 (LIST \$179)

The Perfect Pair for Those That Want RTTY at its Finest. Here's Your System. Audio From Your Receiver Direct Into the M75 and Out Comes Teletype on Your Zenith Monitor.

SAVE \$100



List \$610.00

SAVE \$121.00
EEB Special Discount
Plus \$60
Factory Rebate
\$549.00 Discount
- \$60.00 Rebate

Your Cost \$489.00
After EEB Discount
and Factory Rebate

OTHER INFO TECH SPECIALS:

- M500A5R, Multi-mode Comm. Terminal NOW \$1199.50 with rebate (Reg. \$1475.00)
- M300C, Tri-mode, Terminal only keyboard NOW \$354.00 with rebate (Reg. \$450.00)
- REBATES GOOD THRU DEC. 31, 1982



CWR-6700 TELEREADER
RECEIVE-ONLY
RTTY/CW TERMINAL
LIST \$499.00

Now you can also enjoy shortwave listening to RTTY and Morse code transmissions with a unit designed for that purpose. The CWR-6700 offers many advanced features, previously available only in more expensive transmit-receive terminals. Some of these features are:

- Receive ASCII, Baudot, or Morse code transmissions and see the decoded characters on the TV monitor screen
- RTTY speeds from 45 to 300 baud (60, 66, 75, 100 and 300 wpm)
- CW speeds from 4 to 99 WPM
- Instant Speed Tracking for Morse Code Over Wide Speed Range From 2 to 99 WPM
- Operates From 12 V.D.C.

THE NEW MBA-RO



FEATURES:

- 32 Characters for Easy High Speed Copy of Morse
- ASCII and Baudot RTTY
- No Receiver Modification Necessary
- Instant Speed Tracking for Morse Code Over Wide Speed Range From 2 to 99 WPM
- Operates From 12 V.D.C.

ONLY \$269.95 Reg. \$299.95

Optional AC-1 600 MA 12V Adapter \$14.95

Kantronics Code Reader



Buy the Kantronics Mini-Reader and put RTTY and CW readout in the palm of your hand. Decodes Morse (CW) and all common speeds of teletype (RTTY) BAUDOT-ASCII. Complete with 9 volt adapter and display stand. Plus into your audio output. **SALE \$249.95**

B & W MODEL ASW711-49

Only 40 feet long
NEW PATENTED HIGH EFFICIENCY TRAPS
Automatically tunes the popular 11, 12, 16, 19, 25, 31 and 49 short wave bands.
Can be installed as a flat top.
PRICE \$37.50 plus \$2.00 shipping

CABLES: RG-58 With PL-259
20 ft. \$ 8.99 50 ft. \$12.99 100 ft. \$19.99

The McKay Dymek DA 100D All Wave Receiving Antenna

Frequency Coverage 50 kHz to 30 MHz, continuous
Antenna Height 4 feet 8" (142 cm)
Output Impedance: Switch selectable 50, 100, 500 ohms
Amplifier Compression Point: 3.0 Vpp (+13.5 dBm) delivered to a 50 ohm load
Power Required: 110-120 or 220-240 VAC switch selectable, 50-60 Hz, 4 watts or 12 VDC 0.4 Amp

Active antenna — works better than 100 ft. long wire; easy to install; low noise pre amp at antenna base. The answer for apartment dwellers & travellers.

LIST \$159 SALE \$139

ICOM The World System

IC-R70

A WORLD CLASS RECEIVER FOR THE SERIOUS LISTENER



Frequency Coverage — 100KHz to 30MHz
Receiving Modes — AM - SSB - CW - RTTY (FM optional)
I.F. Frequency — 1st 70MHz, 2nd 9MHz, 3rd 455KHz
Dynamic Range — 100 db at 500Hz BW
Audio Output — 3 watts 8 ohms 10% distortion
Power Supply — AC 117-220V 50/60Hz 25 watts
DC 13.8V ± 15% 10 watts
Size — 11.25" w, 4.33" h, 10.86" d, 16.25 lb. wt.

- Pass Band Tuning
- Notch Filter
- CW-RTTY Wide/Narrow
- Computer Compatible
- Fully Synthesized
- Noise Blanker Wide/Narrow

Sensitivity — SSB-CW-RTTY — .16uV for 10 db S/N
AM — .5uV
Optional FM — .32uV (12 db sinad)
Selectivity — SSB-CW-RTTY — 2.3KHz
CW-N RTTY N — 500Hz
AM — 6KHz - 3KHz PBT
FM (optional) — 15KHz

ICOM, a world leader in amateur radio, now introduces a revolutionary receiver not previously available for under \$1500. Priced at only \$749.

As Advertised on WRNO New Orleans

Special Introductory SALE \$695

YAESU FRG-7700

EEB'S BIGGEST SELLER
LIST \$549 SALE \$479
SAVE \$70.00

	List	SALE
MU-7700 Memory Unit	149.00	135.00
FRV-7700A VHF Converter	149.00	135.00
FRV-7700F VHF Converter	149.00	135.00
FRT-7700 Antenna Tuner	59.00	
FRA-7700 Active Antenna	59.00	
FF-5 Low Pass Filter	20.00	
DC-7700 DC for FRA-7700	8.00	

10% Off List Prices on Accessories
With Radio Purchase



- Coverage of 150 kHz through 29.99 MHz on AM, SSB, CW and FM.
- Digital frequency display using bright yellow LED digits for maximum visibility.
- Built-in quartz digital clock with timer for control of station accessories.
- Three AM bandwidths for changing interference conditions on crowded shortwave broadcast bands.
- Tape recorder output jack on front panel.

As Advertised on WRNO New Orleans

Record while you're away using the built-in on/off timer.

- Noise blanker, AGC selection, and RF attenuation level controlled from front panel.
- Optional memory unit allows storage and recall of up to twelve frequencies — no more frantic dial twisting at I.D. time! A backup feature holds memory channels while the FRG-7700 is turned off.
- Optional accessories: FRV-7700 VHF Converter, FRT-7700 Antenna Tuner, FRA-7700 Active Antenna, FF-5 500 kHz Low-Pass Filter, DC-7700 DC Kit, YH-77 Headphones.

KENWOOD R-1000



SALE \$449.95
LIST \$499.95

COMMUNICATIONS RECEIVER

Frequency range 200 kHz-30.0 MHz. AM, SSB, and CW modes. Built-in noise blanker. PLL synthesizer covers 30 bands between 200 kHz to 30 MHz. Ideal 3-stage IF filters for receive mode. Built-in quartz digital clock with timer. Power requirements 100, 120, 220, 240 VAC, 50/60 Hz, 12 VDC option.

KENWOOD R-600



SALE \$359.95
LIST \$399.95

KENWOOD R-600 General Communications Receiver. — 150 kHz to 30 MHz continuous coverage of the AM, SSB and CW bands. Features 30 band coverage, PLL tuning, tone control and selectable AC power, 100/120/220/240 V, 12 VDC option.

PORTABLES

SONY

ICR 4800	\$ 79.95
ICF 7600A	\$139.95
ICF 6500W	\$169.95
ICF 2001	\$269.95
ICF 6800W	\$549.95

PANASONIC

RF 085	\$ 84.95
RF 2200	\$159.95
RF 2600*	\$179.95
RF 2900	\$249.95
RF 3100	\$269.95

*Close Out

G.E. WORLD MONITOR II \$169.50

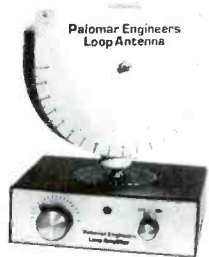

Palomar Loop Antenna

A low-noise receiving antenna for the low frequency bands. Rotates and tilts for deep nulls, self-contained amplifier boosts signal and matches loop to your receiver.

Loop Amplifier Matches loop to Rcvr	77.00
1.6-5 MHz plug-in loop (160m, 80m)	59.95
1.6-5 MHz plug-in loop (AM broadcast)	59.95
150-550 KHz loop (VLF, 1750m)	59.95
40-150 KHz loop (WWVB, Loran)	59.95
10-40 KHz plug-in loop (10mega)	59.95
5-15 MHz plug-in loop (HF-1)	59.95

- We ship world-wide
- SASE for FREE Catalog
- Foreign 3IRC's Air Mail
- Shipping charges not included
- Prices & specifications subject to change without notice
- SORRY—NO COD's

10-5 TWF
10-9 TH
10-4 Sat



Electronic Equipment Bank

516 Mill Street, N.E.
Vienna, Virginia 22180

Order Toll Free 800-368-3270

Virginia 703-938-3350

Closed Sunday and Monday



10 Miles West of Washington, D.C.

CIRCLE 66 ON READER SERVICE CARD

www.americanradiohistory.com

ALAN PINKERTON
PRINCIPAL

GEO. H. BANGS, Gen'l Supt.

Robert A. Pinkerton, Supt., 66 EXCHANGE PLACE, NEW YORK

Benj. Franklin, Supt., 45 SOUTH THIRD STREET, PHILADELPHIA

E. Wanner, Supt., 191 & 193 FIFTH AVENUE, CHICAGO

W.A. Pinkerton, " " " " " "

Clarence A. Seward, Attorney and Counsel for the Agency, 29 NASSAU ST. NEW YORK.

PINKERTON'S NATIONAL DETECTIVE AGENCY

We never sleep.

Pinkerton's was one of the earliest private detective agencies in the United States.

CT	Northford	KAI855	463.75
	Vernon	KVW637	463.575
DC	West Hartford	WAB258	463.575
	Washington	KTD740	31.20
		KD5562	154.57
		KB6574	495.7625
FL	Jacksonville	KZB907	464.35
		WCV993	464.35
	Miami	WAW782	475.1625
GA	(hand-helds)	KA66551	151.715
	Atlanta	WLF21	464.725
HI	(portable)	WZJ619	464.55
IL	Chicago (hand-helds)	KJ3405	151.625
	Cordova	KZU773	154.515
	Rockford	KSL773	154.515
IN	Indianapolis	KKY419	463.275
		WFN841	463.275

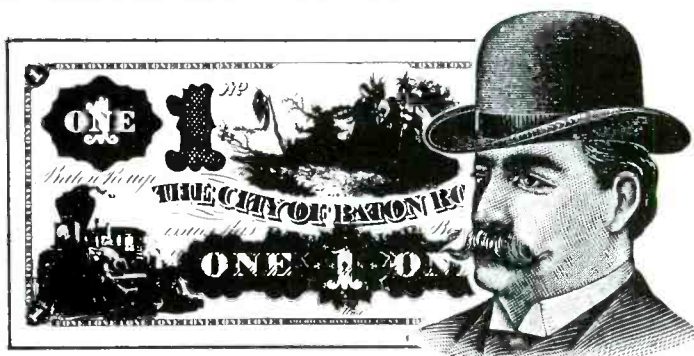

The agency cracked a large counterfeiting ring; after that, its reputation grew.

YOU'RE MISSING HALF THE EXCITEMENT!

More than half the long-range non-commercial communications are in code or RTTY. Now you can hear what you've been missing with the Kenwood / Kantronics package. Tune in the world of action and excitement that has been unreadable.

MADISON
Electronics Supply

1508 McKINNEY
HOUSTON, TEXAS 77010
713-658-0268



Kenwood R600 \$399.00

Freq. coverage 150 kHz-30 mHz
 Selectivity - AM wide 6 kHz ± 6dB
 AM narrow > 27 kHz ± 6dB
 SSB/CW
 Sensitivity - .150 kHz-2mHz
 AM - < 50mV
 SSB/CW - < 5 mV
 2 mHz-30 mHz
 AM - < 5 mV
 SSB/CW < 5 mV
 Reception Modes - AM/SSB/CW

Kantronics Hamsoft Interfaces 189.00

Interface cable & kit 39.95

Home Computer 99.95*

\$727.90

*Sinclair ZX81 kit as of 8/82

CIRCLE 71 ON READER SERVICE CARD

IA	Davenport (hand-helds) Des Moines	KJ3405 KSR333 WCN477	151.625 461.25 461.25	New York City	KAB4050 WGH704 WCF822	462.625 807.8375 807.8375	
KS	Burlington	KFK774	151.775	(hand-helds)	KY9869 KEW986	807.8375 852.8375	
KY	Fairdale Louisville (hand-helds)	KSP553 WEF34 KP2273	463.375 463.375 463.375	Plainview Saratoga Springs (paging)	KST385 KEH618 KTQ431	462.075 151.865 157.74	
LA	Baton Rouge Bridge City New Orleans	WQJ394 KEI962 KSX750 KEI966 WCF741 KZ8261	461.725 463.925 151.745 463.925 463.925 463.925	Yonkers NC ND OH	(hand-helds) Beulah Cincinnati Cleveland (hand-helds) Columbus Dayton Independence Parma Toledo	KAB4069 KA46732 WXA480 KSX749 WSF529 KA65042 KSU930 KTJ332 WGF429 KTK349 KSP326 WRI618	462.625 465.90 151.775 151.745 463.425 463.425 151.685 151.745 463.425 151.955 151.925 463.20
MD	(hand-helds) Baltimore (hand-helds) Towson	KTL725 KP9180 WIY71	464.95 464.95 464.95	OK PA	Oklahoma City Philadelphia (hand-helds) Pittsburgh (hand-helds) Columbia	KST934 KUS792 WPI53 KQ5412 KTB604 KO7985 KLP457	151.775 461.325 461.325 461.325 151.895 467.15 35.72
MA	Boston Woburn	KJG396 KTC772	151.715 151.715	RI SC	Memphis Dallas Houston	KAB5178 KCF560 KUH452 WLW32 KO9563 WSR627 KST544	462.55 151.655 461.70 461.70 461.70 462.875 464.30
MI	Detroit (hand-helds) Grand Rapids Lansing St. Joseph Southfield	KST605 KP3363 KTN598 KMB319 KMB616 WGL79	461.075 461.075 151.925 151.925 151.925 461.075	TN TX	(hand-helds) (hand-helds)	KAB5178 KCF560 KUH452 WLW32 KO9563 WSR627 KST544	462.55 151.655 461.70 461.70 461.70 462.875 464.30
MN	Edina	KRH312	151.775	US	Renner (portable) (portable)	KTL235 WZJ619	151.625 464.55
MO	Clayton Independence St. Louis Omaha (hand-helds)	WBJ668 WOK79 KYG988 KZB895 KKW868 KE8445 KSW524 WGZ42 KP3539	461.025 461.35 151.775 461.025 461.125 461.125 461.275 461.275 461.275	VA WI	Falls Church Milwaukee (hand-helds) (hand-helds)	KNT220 KTA800 KP5918 KP5918 WHH37 WHH37 KA75149	495.7625 461.75 461.75 468.95 461.75 468.95 154.57
NJ	Maplewood	WBY420	474.7375	(hand-helds)			
NY	Albany (hand-helds) Brooklyn (hand-helds) Brunswick Floral Park (paging) Jamaica (hand-helds) (paging)	WHQ93 KP6195 KLH539 KY7901 KTC594 KEH616 KTQ431 KEH617 KD8087 KTQ431	463.65 463.65 471.7375 471.7375 463.65 151.865 157.74 151.865 151.865 157.74	(hand-helds)			

Pinkerton's certainly earned its' place in the history books on the Old West.

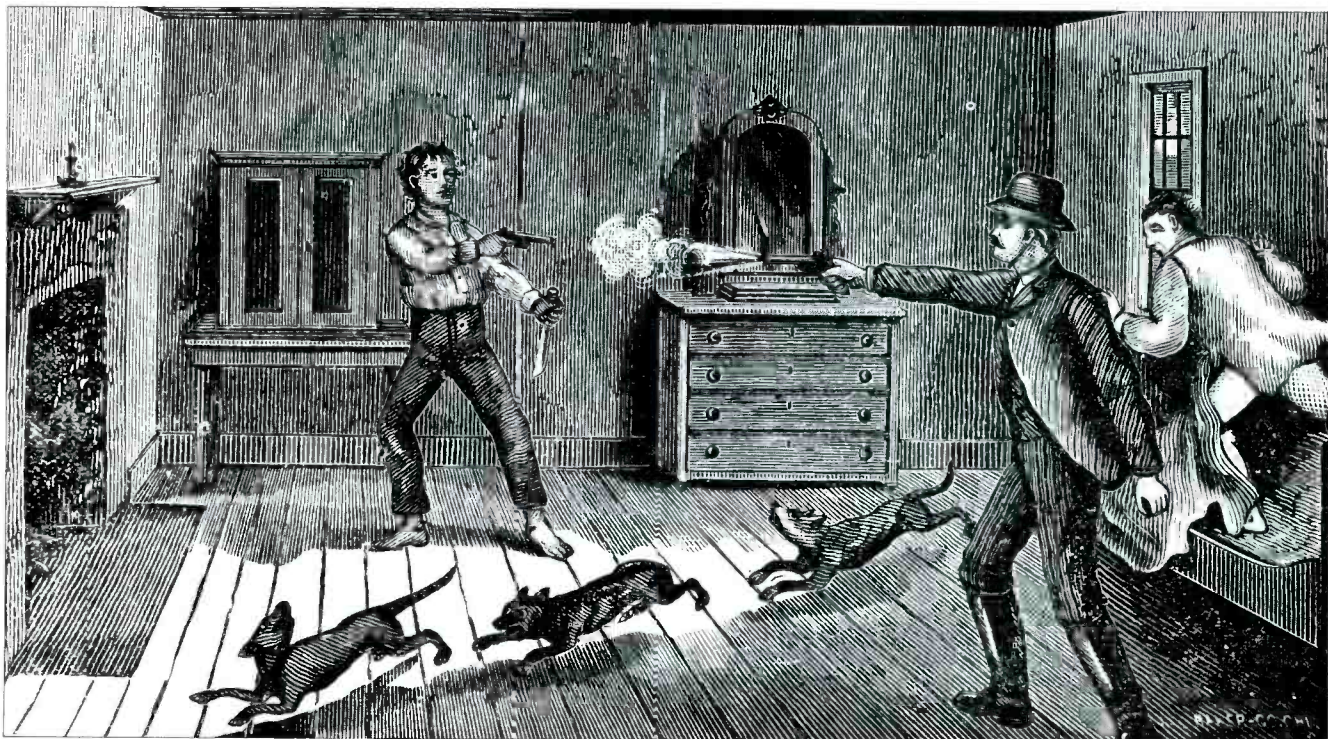



Borrow This Clever Trick From The Commercial Stations – It'll Soup Up Your Shortwave Reception In A Snap!

Diversity Monitoring

BY R. SLATTERY, KAZ7JS

“Thank you for listening to our broadcasts. We are now at the end of our transmission. You have been listening to station . . . in . . . Good night until next time.”

Is there anybody out there with a communications receiver who hasn't had something like that happen to them? You stuck with that weak and fading signal for what seemed like hours just waiting for a station break. You suffered through monologues of what was apparently some form of English and dialogues from persons speaking in some language which didn't bear any nodding acquaintance to other tongues spoken on Earth—even though you knew you weren't hearing Saturn.

You had sort of hoped that you were listening to that elusive clandestine broadcaster which only seems to appear on the airwaves whenever the shooting in that small nation stops long enough for the rebels to string up their antenna and fire up their 100 watt portable transmitter. Or, on the other hand, maybe the station you heard was the one in that fabled Asian kingdom whose station goes on the air only when its temperamental prince feels the nation should be heard from—and he hasn't felt that way in three years. That's the station that offers the QSL certificate in gold leaf on parchment

and signed personally by His Highness (the stamp is a collector's item, too).

You'll never know. The fading, already bad, got even worse at station-break time.

Or maybe you've got a really good RTTY station tuned in, except that the signal fading is causing every fifth word to garble. Or perhaps you're tuned into one of the frequencies used to coordinate a daring air/sea rescue mission half-way around the world. If it weren't for the severe signal fading causing signals to fluctuate between S-6 and nil, you could even follow the action.

Don't hit your receiver with a rock or kick your dog. It won't help.

A Way Of Life

Fading (some call it QSB), unfortunately, is a natural phenomenon associated with long distance radio communications at certain frequencies—especially those lying between the standard AM broadcasting band and about 30 MHz. It's caused by shifts in the ionosphere, those high-flying reflecting layers responsible for bouncing many signals around the globe. These days, satellites have permitted many long range communications services to circumvent the problems of fading. But all DX signals aren't on the

birds—fading simply makes many of them for the birds. Nobody knows what to do about it—or do they?

Fact is, there is a method of attack and it isn't even new. Commercial receiving stations have had occasion to use it for six decades! More than 40 years ago, one manufacturer even brought out a special anti-fading receiver for this technique, which is called “diversity monitoring” or “diversity reception.” DM in its usual form requires two receivers. If you've got two receivers, you're almost in business. Even if you don't, we'll show you techniques that can prove helpful to the harried listener attempting to fight back at the cruel whims of the mischievous gods who control the vagarious atmosphere.

Two receivers are normally used for DM in order to take fullest advantage of two antennas that are not connected or coupled to one another. Fig. 1 tells the story. Ideally, the two antennas should be at right angles (90°) to each other. The best bet is for one receiver to be connected to a horizontal and the other hooked up to a vertical antenna—unless you have room for two separate horizontal antennas spaced from 2 to 10 wavelengths apart. If you have room for two horizontal antennas but can't put lots of space between them, then position the horizontal

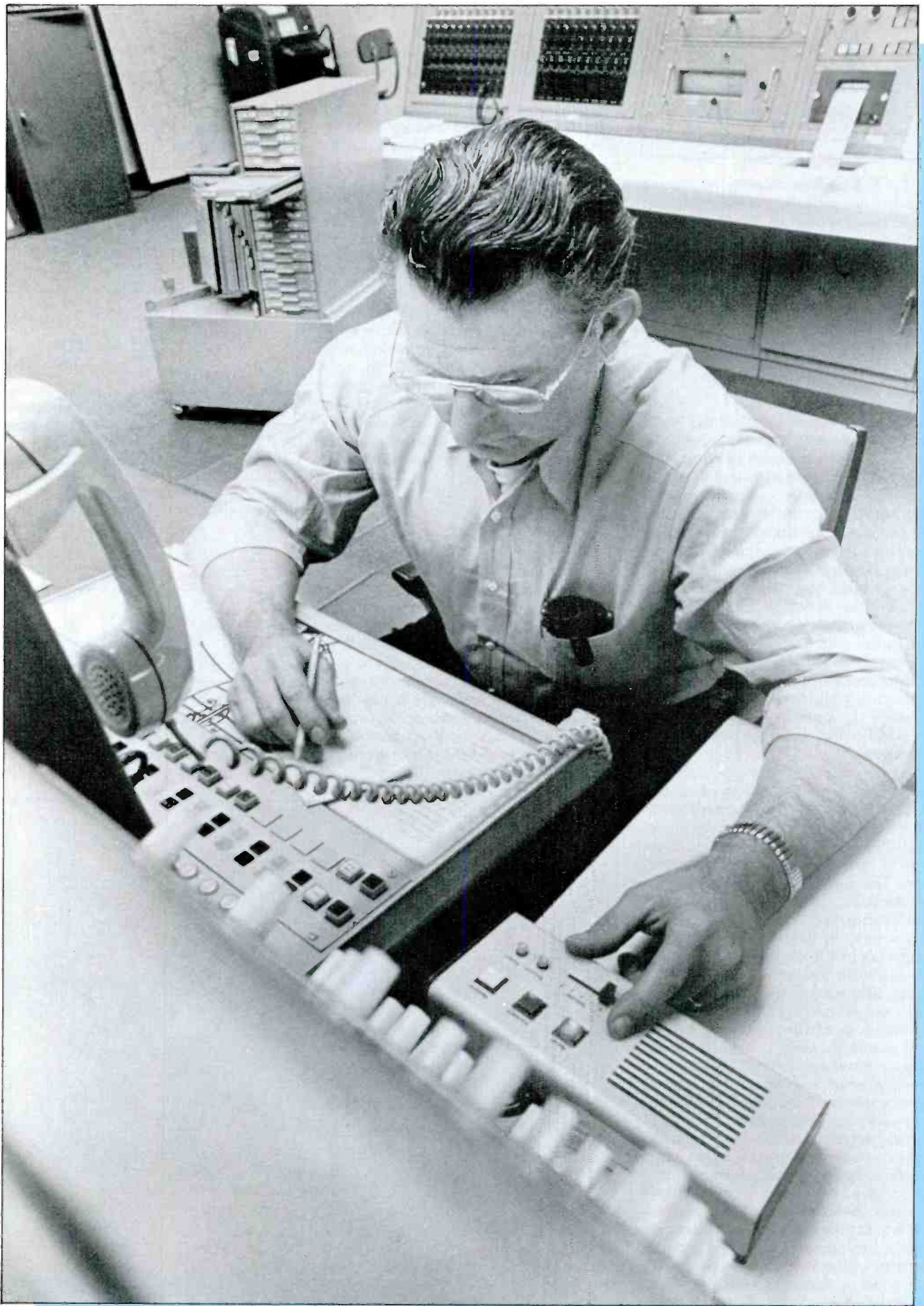

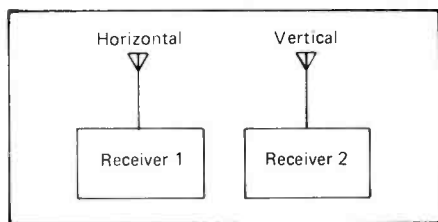

Fig. 1- The simplest diversity monitoring setup uses two receivers, each connected to its own separate antenna. One is mounted vertically, the other in a horizontal plane.

antennas at right angles to one another since running them parallel or stringing them at a 45° angle won't offer any benefits.

The Problem

Why two antennas? Consider that signal fading problems are not simultaneously uniform across either the radio spectrum or at different points on the surface of the earth, or even at the same frequency and location using vertical or horizontal polarization.

Sometimes signal fading is caused by the ionosphere failing to sustain its reflecting qualities at certain frequencies. If you listen above 14 MHz, you note that as the day wears on, the signals start to deteriorate, and by evening you can't get much DX from these frequencies. The period when the deterioration begins to fade is especially severe as the ionosphere begins its higher frequency nosedive. While this is taking place, lower frequency signals may not be affected by fading and, in fact, may even be substantially improving!

Another reason for fading is multi-path transmission. Some of the DX signal reaches the receiver, say, via one reflection from the ionosphere. But other bits of signal energy arrive after having bounced from the ionosphere to earth to the ionosphere and back again. This makes one signal path longer than the other. Crazy, no?

With two sets of waves coming in, everything is okay as long as their crests and troughs happen to match up in unison. If there is a slight mismatch, the signal will be weaker, although still readable. But let the ornery ionosphere get especially restless (as it so often does) and the wave crests may begin to overlap the wave troughs. When this happens, the signal starts to fade appreciably and fall apart, and may even drop out altogether at times. It's a case where the station's own signal cancels itself!

Multi-path fading can be dodged to some extent by two well separated antennas, or sometimes by two adjacent antennas run at right angles. While two incoming wave trains may be overlapping the wrong way (that is to say, be out of phase) and canceling one another at the receiving antenna, they may well be arriving in fine fettle at the other antenna. Comes the next ionospheric shift and the waves might start to add on the first antenna and cancel one another at the second antenna. In this case, it's a matter of

getting the right antenna under the right signal at the proper time! Presto!

Polarization shifts also cause their own fading problems. You perhaps know that a signal is polarized as it leaves the transmitting site, the direct result of whether the transmitting antenna is mounted in a vertical or horizontal plane (and yes, I have heard of some applications which call for right or left "handed" circular polarization). For relatively short hauls, best reception will be obtained when the receiving antenna picking up a signal is mounted in the identical polarity as the transmitting antenna. But after the signal has propagated some distance and taken at least one bounce off the ionosphere, its polarization gets a little mixed-up. In fact, the signal arrives at the receiving point with some of its energy vertical, some horizontal, but not necessarily in equal doses. There appear to be extended periods of time (I'm talking about several days) when vertical components of a particular signal will fade less than the same signal's horizontal parts; then, just the opposite situation will occur a few days later!

Hearing It All

Commercial receiving installations attempt to fake out all of this by establishing as many as three different receiving antennas for the best possible reception of DX signals. They run the antennas into three receivers, as shown in Fig. 2. The outputs of the three receivers are fed into a mixer and finally go through one audio amplifier and one speaker. The result is a composite signal that is made up of the best possible elements of the various inputs. But you don't have to get that carried away with the project in order to put DM to work for yourself.

Matter of fact, if you don't own two (or even three) receivers, you can try the hook-up shown in Fig. 3. Simply erect the additional antenna or antennas and rig a low-loss switch so that you can change antennas in a jiffy. If your lead-in is a simple wire, you can get away very inexpensively by using an SPDT knife switch—although if you're using

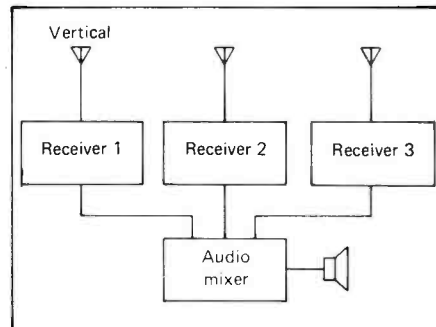

Fig. 2- Commercial and military receiving stations have a more sophisticated setup. Three antennas feed one speaker.

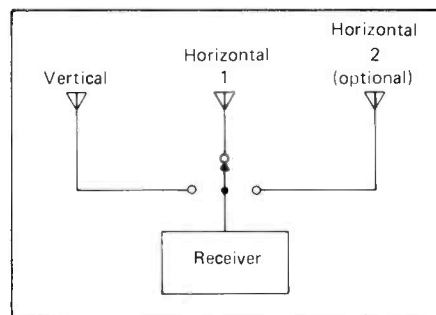
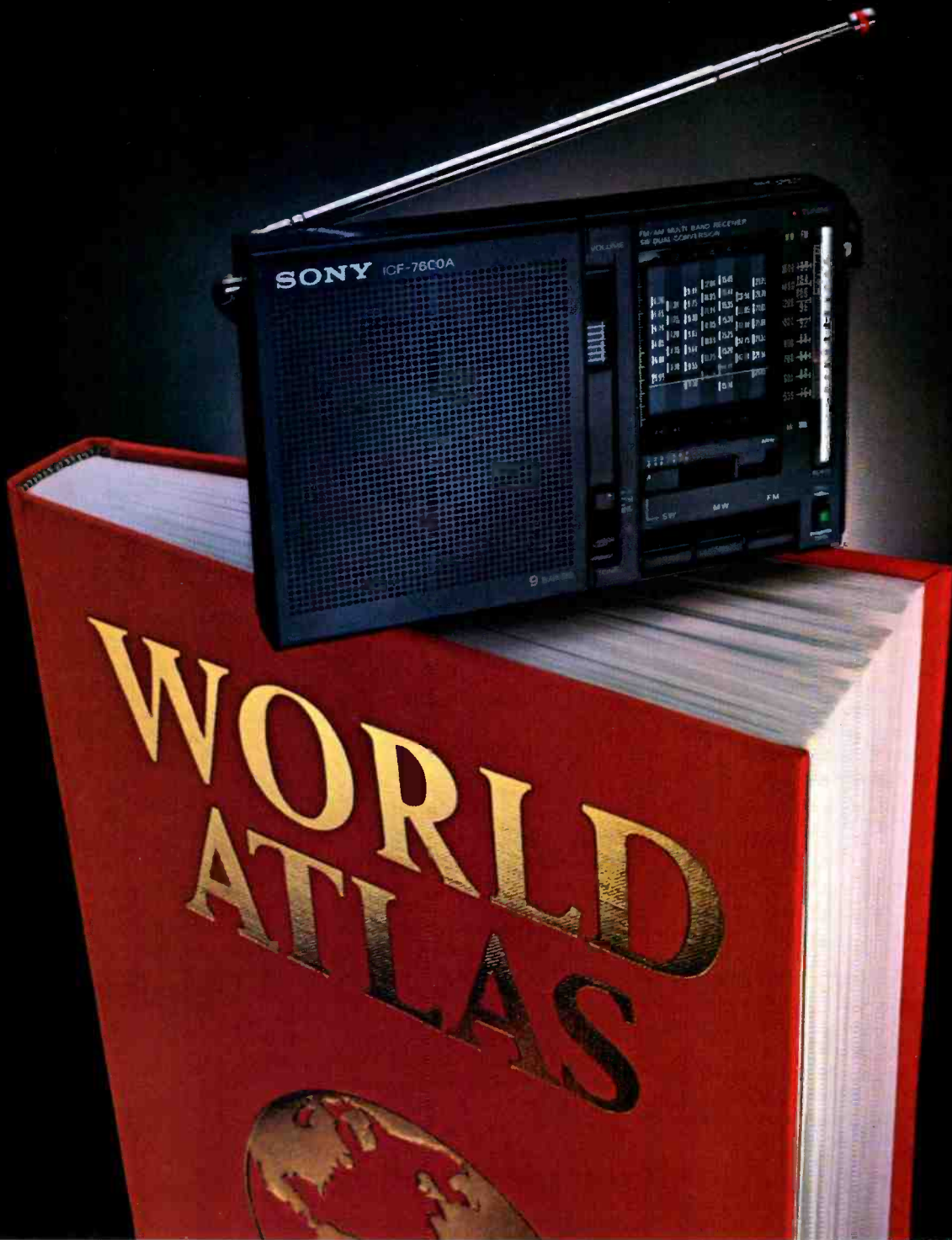

Fig. 3- Two or three antennas and one receiver can be set up for diversity monitoring at your own station. It's simple and inexpensive, and does a good job of minimizing the effects of signal fading.



The Heathkit SA-1480 Remote Coax Switch allows the user to choose any one of up to five antennas from a remote location.



It's a small world.

Your eyes aren't deceiving you. You're looking at a Worldband radio that's very, very small.

Almost as small as a paperback book.

Gone are the days of a room filled with monstrous radio equipment and all its knobs and dials. The easy-to-use Sony ICF-7600A stands neatly on a desk if you're looking to bring the world into your home. And fits neatly into a briefcase should you travel and like to take the world with you.

It's a wonderful thing to own.

It has seven shortwave bands,



plus AM and the full 76 to 108 MHz FM band.

Its special circuitry (including dual conversion) pulls in the signal while filtering out the interference.

The RF amplifier brings in clear, interference-free reception. And separate crystal oscillators keep that reception stable.

So even though you're listening to a station thousands of miles away, this Sony will make it sound like it's coming from around the corner.



SONY
THE ONE AND ONLY

© 1982 Sony Corporation of America. Sony is a trademark of Sony Corporation. Model shown: ICF-7600A.

Buy a Sony Worldband radio and you're eligible to win a free trip for two to the faraway place of your dreams. See your participating Sony dealer for details.

CIRCLE 74 ON READER SERVICE CARD
www.americanradiohistory.com



Radio Shack's Archer brand offers this low cost switch for antennas.

coaxial cable, you'll want to obtain a low-loss ceramic switch made to accept coaxial type connectors.

An even better approach is to obtain a preselector which will accept two antenna inputs (such as the MFJ-1040, reviewed in our September issue) and boost whatever signal levels arrive at the antennas (Fig. 4). Since fades often last several seconds—especially the deeper ones—and it only takes a fraction of a second to switch antennas by hand, you'll be able to change to another antenna quickly enough so as to get all or most of what you're trying to monitor. Besides, having this antenna switching capability will enable you to determine which is the best antenna for a given signal during any partic-

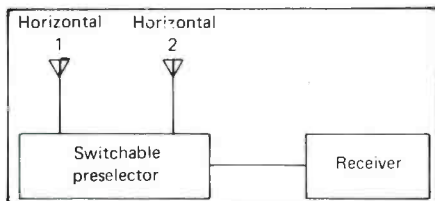

Fig. 4- Another variation of Fig. 3 (as used at the author's own station) feeds both antennas into a preselector containing the switches. This permits him to rapidly select the one offering optimum reception during deep fading periods, while the signal amplification provided by the preselector also helps to minimize the low points (troughs) of the fluctuating signals.

ular time while propagation conditions are relatively stable.

If you build a three-antenna setup and have another receiver handy, why not try the hookup in Fig. 5? This enables you to try the two horizontals and then each horizontal with the vertical to see which is the best combination. While you can easily get used to hearing the signals emerging from two speakers by just "mixing" them "in your head," I suppose that it would not take much effort to feed the signals from two receivers into a pair of stereo headphones—one receiver into each earpiece.

Two receivers allow you to attempt to monitor one shortwave broadcast station on two different frequencies that it is using simultaneously. For instance, tune one re-



MFJ's Model 1040 lets the listener select antennas and also boosts signal strength.

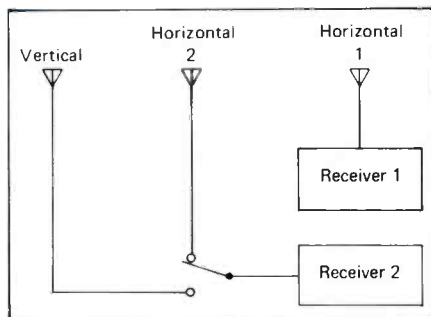
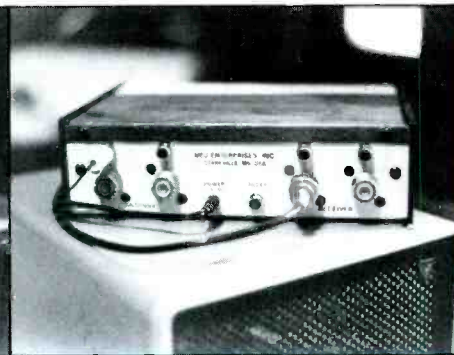
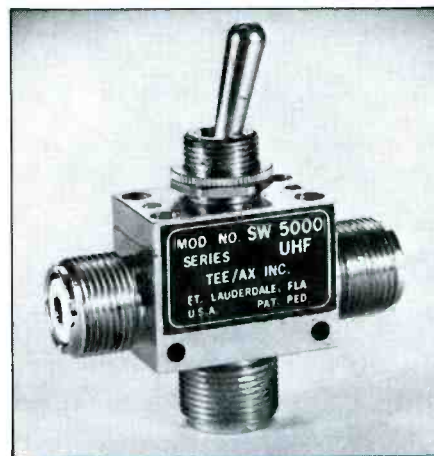

Fig. 5- Adding a second receiver to the installation shown in Fig. 3 brings in better all-around reception.

ceiver to the station's 9 MHz channel, the other receiver to an 11 MHz outlet of the same station. Between the two you should be able to beat the fading demons at their own game. For this stunt, you'll probably only be able to use one antenna with a T-connector. In most cases, there should be minimal harmful interference resulting from interaction of the two receivers on the same antenna. See Fig. 6 for a depiction of this idea.

Two heads are better than one, or so the old saying goes. Two or three antennas or receivers are better than one, especially if you know the trick of using them for DM. Having an additional antenna or receiver on tap also gives you a spare should something put one antenna out of business.



A two position toggle type antenna switch.

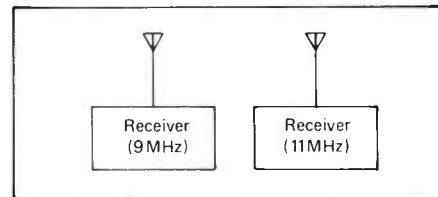

Fig. 6- By using two receivers to independently monitor two simultaneously broadcast signals of the same station, you can usually come out ahead. You might try this trick with one antenna feeding both receivers.

A Historical Note

The principal of DM was evolved as early as 1923 by H.H. Beverage (inventor of the "Beverage wave antenna"), and H.O. Peterson of RCA's research and development labs. They had created the theory that if the outputs of several spaced antennas were combined, the average value of the several would be more constant than the value obtained from a single antenna.

After they figured this out, experiments were performed that proved spaced antennas had different fading characteristics. The experiments also indicated that not only did the signals from the spaced antennas vary in different manners with respect to intensity, but also with respect to phase. Attempts to combine the radio or intermediate frequency of the signals showed that there were instances when the signals from the two antennas were of the right phase to aid one another, but that there were also instances when the phase was such that phase opposition occurred. Such a phase variability precluded the possibility of combining the antennas directly in the manner that long wave antennas had been combined.

Many means were devised to combine the signals, irrespective of phase, but the one showing the most promise proved to be the process of rectifying the alternating current energy of the various signals from the spaced antennas and adding the resulting direct currents. The alternating voltages, as received from the individual receivers, were merely passed through vacuum tube rectifiers so that their voltage was no longer an alternating voltage requiring proper synchronization or phasing, but a direct current with constant polarity that could be added to any other direct current by the mere process of securing the proper initial polarities for combination. The process was thus converted from a problem analogous to synchronizing several alternators that varied in phase to one of connecting several batteries in series or parallel. (Quoted from *Radio News Magazine*, August, 1933.)

INFO-TECH M200-F TRI-MODE CONVERTER

The Best in
Code
Converters



Converts Morse & RTTY (Baudot & ASCII) to video,
and serial Baudot or ASCII for hard copy

Morse reception: 6-55 wpm standard (simple user adjustment for higher speeds). Automatic speed tracking & word space adjustment. RTTY/ASCII Operation: Decodes RTTY (45, 50, 57, 74, 100 Baud) and ASCII (110 & 300 Baud). Auto CR/LF, automatic threshold control, selectable unshift on space, limiter is switch selectable, solid state tuning "meter." Demodulator has 3 fixed shifts and 1 tunable shift, user selectable printer outputs in ASCII or Baudot for all modes with crystal controlled baud rate generator. RS232, TTL & isolated loop outputs. User adjustable autostart.

- Video Display Formats: up to 25 lines of 72 characters
- Built-in 115/230v power supply

Contact Us for Further Information and
Name of Your Nearest Dealer

INFO-TECH ELECTRONIC
EQUIPMENT

Manufactured by:

DIGITAL ELECTRONIC SYSTEMS, INC.
1833 Wisteria Court • Englewood, Florida 33533
813-474-9518

MADE IN U.S.A.

CIRCLE 70 ON READER SERVICE CARD

COMMUNICATIONS DIVISION

We treat amateurs professionally.

Fifty-four years of experience has taught Harvey a lot more about communications equipment than makes and model numbers. We have learned that the communications enthusiast needs special, highly professional treatment and that's why Harvey has an entire division devoted exclusively to this area.

Fifty-four years of experience has also taught us the value of the old-fashioned ways of doing business. We believe more in expertise than in salesmanship. We want to be of service both before and *after* the sale. If we don't have what you want, we'll either get it for you or tell you where you can get it yourself. But, we think your chances of finding exactly what you're looking for and receiving the help you need are better at Harvey than anywhere else in the country. Let us prove it to you today.

Yaesu
R.L. Drake
McKay Dymek
President
Cobra

Sony
Panasonic
Bearcat
Grundig

CALL TOLL FREE:

1-800-223-2642

Ask for Dou "Joe" Chin - KB2MU

HARVEY

25 W. 45th St., N.Y., N.Y. 10036 (212) 921-5920

\$1²⁵

That's all it takes to get a copy of the USA-CA Record Book delivered to your door. Order one or two today and start collecting counties for one of amateur radio's most prized awards, USA-CA.

CQ Magazine
76 North Broadway
Hicksville, New York 11801

KAE51

UNITED STATES WEATHER BUREAU
NANTUCKET ISLAND, MASS.

THIS WILL CONFIRM YOUR RECEPTION OF

RADIO STATION KAE51 ON 2776 KCS. AT

0851 GMT ON 26 August 1958

POWER: 350 WATTS, ANTENNA Doublet-coax fed

REMARKS:— also operate on 6977.5 Kcs as
K1D-75 Suggest you secure list of other
WB- Stations from U.S. WEATHER BUREAU
Instrumental Engineering Division Washington, D.C.
Station Electronic Specialist

Several DXers have managed to obtain QSLs from some of these stations over the years, although neither of the stations shown in these QSLs are currently active in the network.

KGD72

UNITED STATES WEATHER BUREAU
WASHINGTON, D.C.

THIS WILL CONFIRM YOUR RECEPTION OF

RADIO STATION KGD72 ON 6977.5 KCS. AT

0531 GMT ON 9/29/58 19

POWER: 1000+ WATTS, ANTENNA DIPOLE

REMARKS:— ANTENNA DIRECTED TOWARD
CAPE HATTERAS

Signed: [Signature]

This SR-116/120 SSB transmitter runs a full kilowatt on 12 channels. It's the type of transmitter now in use in the NWS network.

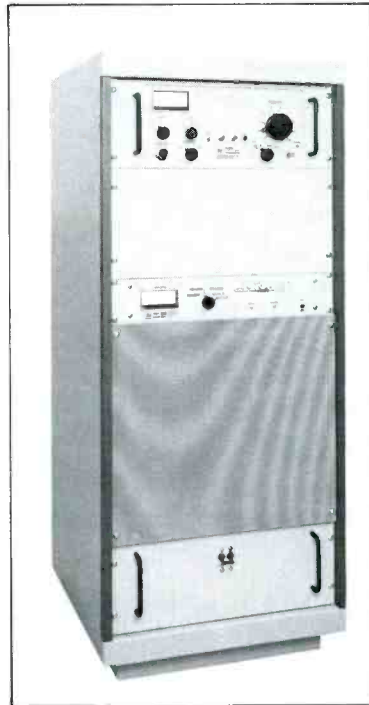

Monitor The National Weather Service's HF-SSB / Emergency Backup Network

BY RAYMOND CARRINGTON, KCA6JL

I'm not quite certain, but the National Weather Service's Single Sideband Emergency Backup Communications may be falling victim to either budget cuts or improved landline facilities. One way or the other, there's a possibility that it may be going the way of the dodo bird and the dinosaurs.

For many years, listeners have monitored this interesting HF communications network, which performs internal NWS functions. It's used for the acquisition of data by National Weather Service offices when their primary communications links (such as landline and Telex) have been disrupted.

These stations are located at NWS offices and operate with 1 kW transmitters. Use of both upper sideband (USB) and lower sideband (LSB) modes has been noted.

At one time, the network had stations along both coasts and even in interior areas such as Goodland, Kansas; Pocatello,



Changing weather patterns sometimes show severe weather which can knock out the National Weather Service's regular communications. When that happens, they press their HF backup system into service.

Idaho; Reno, Nevada; etc. There was a total of 36 stations in all—but that was in the past. At the present time, the network has dwindled down to 21 stations, all located in the Gulf Coast area. In the past, the network operated on 7 different HF frequencies; now it utilizes only 4 channels (although the SR-116/20 transmitters are capable of operation on twelve channels).

While the public-at-large hears both from and about the NWS on a daily basis via the agency's NOAA VHF weather stations, the NOAA Weatherwire Service, and the new AFOS program—this SSB communications network (since it is for internal communications rather than for direct reception by the public) is little known. Not that it's any less exciting to monitor, especially since it is most often heard in operation during severe weather conditions. What makes it all the more appealing is that several monitors have been able to obtain QSLs from these stations, confirming reception. This has been by means of monitor prepared return

type QSLs since (of course) these stations don't have actual QSLs of their own.

The NWS reports that the frequencies currently in use for this network are 2.776 MHz, 3.363 MHz, 6.9775 MHz, and 9.9475 MHz. In earlier days, these stations were also noted operating on 4.9775 MHz, 5.925 MHz, and 14.792 MHz, although NWS no longer reports these as being in active use.

According to the latest information at the National Weather Service, the following stations are presently active in this emergency network:

- | | |
|-------------------|-------------|
| Apalachicola FL | KKE79 |
| Brownsville TX | KHB62 |
| Corpus Christi TX | KGD69 |
| Daytona Beach FL | KHA84 |
| Galveston TX | KGD74 |
| Hatteras NC | KEB86/KEB87 |
| Hondo TX | KGD97 |
| Jackson MS | KED38 |
| Jacksonville FL | KSC41 |
| Key West FL | KOE28 |
| Lake Charles LA | KHA85 |

- | | |
|----------------|-------|
| Miami FL | KGD63 |
| Mobile AL | KCB45 |
| Pensacola FL | KHA60 |
| San Antonio TX | KHB51 |
| San Juan PR | KGD64 |
| Savannah GA | WXK21 |
| Slidell LA | WXN95 |
| Tallahassee FL | KEB81 |
| Tampa FL | KSC48 |
| Victoria TX | KHA54 |
| Waycross GA | KQC42 |

Note that the station in Hatteras (NC) is not presently in this network (as it had been in the past), but there is some possibility that it could be placed back in operation at a future time.

With these stations all running 1,000 watts SSB, they're easily heard throughout North America. Next time there's some severe weather in the Gulf of Mexico (and isn't there always?), you might check out these frequencies and add some new stations to your log while hearing what goes on behind the scenes during a weather emergency.

FREE RADIO FOCUS

BY AL MUICK

ACTIVITIES OF UNDERGROUND BROADCASTERS

Well, here we are again! Last month I reported to you that the Voice of the Voyager had been busted by the FCC again. Now I have the complete story.

The Voice of the Voyager was busted on May 9, 1982, at 0603 hours GMT, at the end of their broadcast on 6840 kHz. Apparently during one of their broadcasts, someone in the northwest (presumably) called the Ferndale, WA, FCC monitoring station, who passed the information to the Chicago Field Office, who passed the information to the St. Paul, MN office. As the Voyager was not located that far from the St. Paul office, once the agents were notified from Chicago and set out to track down the VoV, it took only about 10 minutes. They parked near the VoV and proceeded to monitor and tape the last half hour of the transmission.

Scott, of the Voyager's crew, reports that the Washington, DC office definitely wanted to go for an indictment, but was convinced not to by the St. Paul office since the VoV did not at all resist the bust. As it is, he got off with a \$1000 fine, while Mike, one of the other VoV operators, was hit for \$2000 because he was present when the Voyager was last busted. Appeals for fine reductions have been filed, but no word yet on any results. Scott was surprised at the amount of information the Feds had regarding the Voyager operation, past and present. The local agents were quite well informed and had a lot of well-researched knowledge.

One of the agents told the VoV that their maildrop was as illegal as operating a station, though that "wasn't their department." Several knowledgeable sources say that this allegation is erroneous. We believe an exaggerated claim of the FCC is "that for every listener you've got out there, a few people are calling the FCC." Thanks to Gregg of the Society for Hearing Illegal Transmissions (P.O. Box 345, Watertown, CT 06795) for helping me out with this information!

According to an article in the *Indianapolis Star*, Jolly Roger Radio, a pirate station that was busted in the summer of '80 but had operated for almost ten years straight, wants to get back on the air. After their raid, in which FCC agents promised heavy fines and possible imprisonment, they only received an application for a broadcasting license. They had also considered operating from Ireland and from an ocean vessel, but now Bruce says he is going to try to go *strictly* legal. We wish him lotsa luck.

And from *The New York Times*, an unlicensed radio station called WBUZ is currently in operation over the New York airwaves. It reportedly uses 18 watts output power and is one of more than a dozen pirate radio stations operating in New York City and its sur-



E.M.R.'s studio.

rounding areas. According to the article, the FCC claims that pirate stations on the FM band pose public safety hazards because they may interfere with the commercial aircraft band. The DJ is "Steven Roach," and his programming is anything but predictable. The operating frequency of WBUZ is 103.1 FM and was chosen because "Steve" felt he would reach more listeners here than on some obscure frequency. So, if you find yourself in Long Island, why not give a listen to WBUZ! Thanks to Dave Beauvais, KB1F, who sent this to me.

KQSB is a pirate station from the west coast that has been operating sporadically on 7426 kHz around 0300 GMT. They play Top 40 style music and use Box 4948, Arcata, CA 95521 as a mail drop.

KCFR is a pirate station that is looking for programming input from its listeners! If you would like to record a program (multiples of 30 minutes, please) and have it broadcast over a pirate station, KCFR is the station to do it on! The only requirement is that you keep it clean, but KCFR reserves the right to edit and/or refuse to broadcast the program. Their address is c/o Box 4948, Arcata, CA 95521.

Surfside Radio has started transmissions again after being inactive for almost eight months. They use 6576 or 6276 kHz from their programs around 0100 GMT. WHFO was heard on 6275 kHz around 0510 GMT playing Beatles music and taking quite a few hits from jamming. Radio Free Radio was noted on 7425 kHz SSB at around 0330 testing and telling listeners that they were going to "QSY up frequency." Sounds like a VFO operation to me. Free Radio North America also appeared on 7430 kHz at around 0130 GMT. The Voice of Syncom, an old favorite from the past, showed up

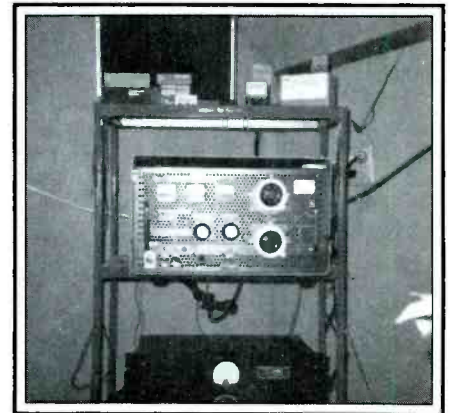

KFWC transmitter — 570 kHz.

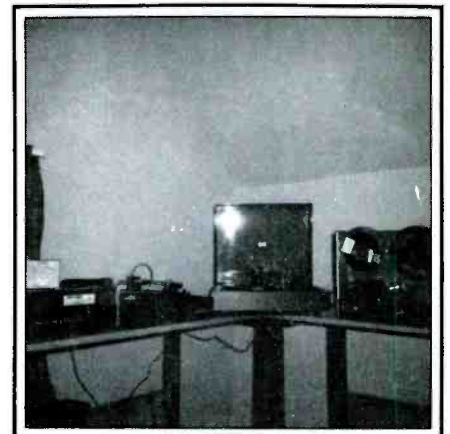

KFWC — AM studio being set up.



Guido, with WRFI ball-peen hammer, poised for action.

again on 14750 kHz at 1900 GMT, but reception was very weak.

During the Falkland Islands crisis, another type of station popped up. Radio Free Falkland Islands, which appeared on 7425 kHz, said that they were part of the front for the independence of the Falkland Islands. They also claimed that they were trying to mobilize the spirit of youth on the Falklands. Considering that the broadcast originated from the USA and that the frequency was not the

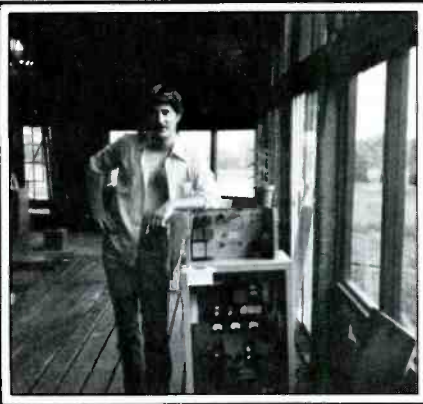

Q, the Night Doktor with transmitter and some assorted vegetable compounds.

best, I seriously doubt as to whether any Argentine youth heard it.

On the sour side of the grape, the FRC-USA has ceased publication of *The Wavelength* as the printing costs here in Germany are just too darn high. But for the lighter side of the news . . . for those of you who are not technically minded but would like to find out about a top grade, AM, FM, or shortwave transmitter, well, have we got a connection for you! Chris Matthews and Bev Anderson specialize in providing high quality broadcast transmitters at very reasonable prices. They can be reached at P.O. Box 35, Wellington, Telford, Shropshire, in England. This is Al Muick saying 73s and Fight For Free Radio!

Your own satellite TV system for \$2,586.⁰⁰ 10 FT. PARABOLIC

What the system will do:

You can receive up to 60 channels of T.V. direct from satellites to your home receiver. Movies, sporting events, religious programs, other T.V. stations, and much more.

What the system includes:

1. 10 ft. fiberglass dish made of reflective metal bond with fiberglass. Weather-resistant and virtually maintenance-free. Dish comes in 4 sections.
2. Single pedestal heavy duty polar mount for extra strength and installation simplicity; easy satellite to satellite adjustment.
3. Four pole rotator mount for more stability, square tube legs and rotator included.
4. All aluminum LNA mount and horn holder for accurate aiming of LNA. All aluminum, weather-proof LNA cover.
5. Drake ESR-24 Receiver or Auto-Tech Receiver. Your choice. Down converter located at the dish.
6. Amplica or AvanteK LNA 120°.
7. Chapparel Feed Horn for unsurpassed quality.
8. All accessories included.

Complete Systems, Receivers,
Antennas, LNA's & Accessories
CALL US TODAY! 901-795-4504

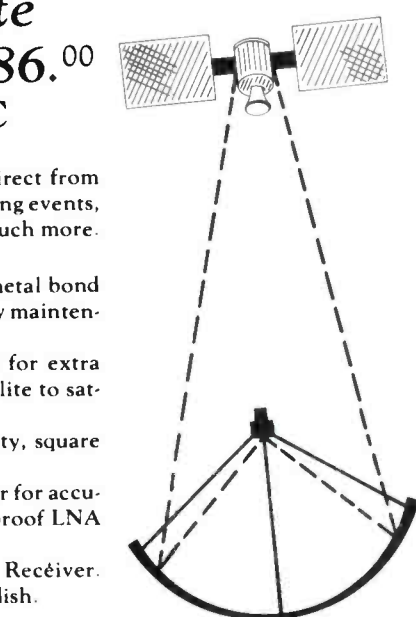

ALSO 13 FT. PARABOLIC DISHES

TENNESSEE ELECTRONICS
— P.O. BOX 181108 —
MEMPHIS, TENNESSEE 38118

CIRCLE 23 ON READER SERVICE CARD

Twelve times each year 64,128 active Amateurs get a taste of a different kind of Amateur Radio magazine . . . one that they read cover to cover . . . and they enjoy. It's more than just a magazine. It's an institution.



The Radio Amateur's Journal
76 North Broadway
Hicksville, NY 11801



SUBSCRIBE TODAY!

Please send me CQ for Life 3 Years 2 Years 1 Year
This is a Renewal New Subscription Starting With _____ Issue.

Name _____ Call _____
Street _____
City _____ State _____ Zip _____

Paid by: Check Money Order

Master Charge VISA



Account Number

Rates (check one)

	USA	VE/XE	Foreign
<input type="checkbox"/> Life Sub	\$280	—	—
<input type="checkbox"/> 3 Years	\$ 36	\$42	\$48
<input type="checkbox"/> 2 Years	\$ 25	\$29	\$33
<input type="checkbox"/> 1 Year	\$ 14	\$16	\$18

Account Number: _____

THE EXCITING WORLD OF RADIOTELETYPE MONITORING

The selection of a proper receiver for RTTY monitoring should be done carefully, while noting that all the required features and certain specifications, such as stability parameters, play an important role in successful reception of FSK signals and tend to be very apparent when monitoring over a long period of time. Let's look at the individual specifications and determine what is important to commercial RTTY reception.

We have seen an abrupt change in the design of new shortwave receivers. Pre-1970 communication receivers tended to be a double or triple conversion superheterodyne, using a mechanically-tuned variable frequency oscillator (VFO). This VFO often used a permeability-tuned oscillator. Since the VFO is one of the largest causes of drift in the radio receiver, some effort was usually made to control this drift by forms of temperature compensation of the VFO. In spite of this effort to stabilize the VFO, frequency drift is usually excessive for RTTY commercial monitoring with older receivers. Otherwise, pre-1970 receivers may be used if one "rides" the fine-tuning control to compensate for the drifting center frequency.

Most new receivers use a synthesizer to create a digital VFO system. Since the fundamental frequency source is crystal controlled, the exceptional stability is inherent with new designs. Also, mechanical backlash and calibration errors are greatly reduced with the synthesized approach.

When using a terminal unit with sharp mark and space filters, maximal drift should be less than 50 Hz per hour. Tolerable drift would be less than 150 Hz per hour. Remember, 450 Hz shift determines whether a 1 (one) or 0 (zero) binary signal is to be output. This is obviously much less frequency that would be allowed for upper or lower sideband signals.

Selectivity is of major concern when receiving RTTY. Selectivity is a measure of the ability of a receiver to reject unwanted or interfering adjacent signals. The ideal bandwidth for RTTY reception is actually narrower than SSB voice transmissions, but broader than CW. Selectivity measurements are usually given as 6 dB and 60 dB down bandwidth response points.

The qualitative difference between receivers can be seen in the shape factor or skirt of the receiver. The skirt factor is the ratio of the bandwidth at -60 dB to the bandwidth at -6 dB. An excellent filter would have a skirt factor around 2 (two), and a theoretically perfect bandpass filter would be 1 (one) with perpendicular slopes. Typically, a 2.4 kHz bandwidth at -6 dB and 6 kHz at -60 dB would yield a good skirt factor of 2.5.



This is the R7A Receiver made by Drake.

It is important to note that for selectivity improvements, insertion of a quality, multiple pole IF filter does more to improve commercial RTTY copy than to try to gain selectivity by available audio filters. Although audio filters have their place, chiefly for reduction and nulling of interfering audio heterodynes, strong adjacent signals allowed through the IF passband will cause the AGC to change the overall receiver gain. As the overall receiver gain is reduced due to an adjacent interfering signal, the desired FSK signal drops below the detection level of the TU, causing errors. No amount of audio filtering can eliminate this problem—only quality IF filtering can reduce these errors. A good bandpass selection commercial 425 Hz shift would be a 1 kHz or 1.8 kHz bandpass with a skirt factor of 2 to 3.

Sensitivity is the measure of the ability of a receiver to detect weak signals. This is especially important for commercial FSK reception due to the typical point-to-point directional transmissions used and low power transmitted. This signal will then tend to be quite weak if you are not directly in the transmission path.

Receiver specifications are usually given in microvolts per 10 dB of quieting. Be careful here, though. Some receiver specs use 20 dB of quieting which is nowhere near as

sensitive as 10 dB quieting. A suitable receiver for commercial monitoring should be between .2 μv and .5 μv for 10 dB

$$\frac{S + N}{N}$$

with .2 μv being optimum.

AGC characteristics are very different for FSK than voice or SSB, and when selecting a receiver for RTTY reception, AGC response time ideally will be very fast, with an attack time between .5 and 1 milliseconds, and a release time faster than 75 milliseconds. Many times with a very weak fading FSK signal, it will be necessary to turn off the AGC entirely, operating the receiver "wide open" or maximum gain. Also, the terminal unit should be in limit, allowing fading signals to be successfully copied.

Lastly, we should be aware of spurious response generated by a superheterodyne system. One of these spurious responses is known as image signals. Since the IF will respond equally to difference signals above or below the local oscillator (one correct RF signal and one incorrect), we would like to minimize signal conversions. Newer receivers use a high initial IF stage to get around the image problem, usually 48 MHz or 70 MHz.

Well, these are the key specifications to look for when selecting a receiver for commercial FSK reception. Price, however, can be the most important specification!

Keep in mind that even if some or many of the above optimum specifications cannot be met, any receiver can still be used for news reception with some patience. In listing signals this month, I have included some adjacent FSK signals to fully test your receiver under trying conditions. Successful reception will indicate excellent receiver selectivity and sensitivity.

AFP - Agence France Presse:

Frequency	Location	Time	Language	Shift	Baudot Rate	Normal/Reverse Phase
16183.2 MHz	Fort de France, Martinique	2215 GMT	Portuguese	425 Hz	50 baud	Normal
16184.6 MHz	Fort de France, Martinique	2218 GMT	Spanish	425 Hz	50 baud	Normal

More adjacent Agence France Presse frequencies:

20311.7 MHz	Paris, France	1400 GMT	English	425 Hz	50 baud	Normal
20313.3 MHz	Paris, France	1410 GMT	French	425 Hz	50 baud	Normal

Does anyone recognize this transmission in Spanish? Please write to me at *Popular Communications* if you know what news press this is. Also, send in any unique or rare "catch" information to be published only with your consent.

11013.3 MHz	?	0123 GMT	Spanish	850 Hz	50 baud	Reverse
-------------	---	----------	---------	--------	---------	---------

PRINT THE WORLD



See What You've Been Missing!

Stay in touch with world events, monitor weather, ship traffic, and radio amateurs. Connect to your receiver and display shortwave radio teletypewriter and Morse code transmissions with the new receive-only **HAL CWR-6700 Telereader**.

- Receive ASCII or Baudot RTTY
- Six standard RTTY speeds: 45, 50, 57, 74, 110 and 300 baud
- 3 RTTY shifts for low or high tones: 170, 425 and 850 Hz
1275 or 2125 Hz mark tone
- Adjustable space for fine tuning
- Receive Morse code — 4 to 50 wpm
- 36 or 72 characters per display line
- 20 lines of 36 characters or
- 16 lines of 72 characters on screen
- Two pages of video display
- Parallel ASCII printer output
- Requires +12 VDC and external TV monitor
- One year limited warranty
- Small size (8" × 3" × 12.75")

Write or call for more details. See the CWR-6700 at your favorite HAL dealer.



HAL COMMUNICATIONS CORP.

BOX 365

URBANA, ILLINOIS 61801

217-367-7373

ESTABLISHING SURVIVALIST COMMUNICATIONS SYSTEMS

Ears To Ya!

Every person concerned with surviving a local, regional, or national crisis or disaster—whether it be short-term or prolonged—will want to have access to as much information as possible during the period of turmoil. Severe weather, civil insurrection, breakdown of law and order, floods, earthquakes, prison breaks, nuclear facility accidents, forest fires, and any of a dozen similar spectres seem to come into our lives (or threaten to do so) with ever-increasing regularity and ferocity. These things cause massive reactions from public safety agencies and the public itself. Some communications may be partially disrupted, others wiped out entirely, and still others may operate with increased activity on a wide spectrum of frequencies ranging from low frequencies right on up into the UHF bands.

It seems that the public is always the last to know what's really going on. All too often, a smattering of information is all that is released to the public—and frequently that is disorganized, misleading, and reports from differing sources seem to conflict with one another. Well, that's what happens when panic hits the news media; they run around like a bunch of headless chickens and sometimes create more confusion and problems than is necessary or desirable. Okay, so they

mean well. But that doesn't help you any if you're sitting there trying to decide how to approach the situation yourself. Frankly, they can get you a little crazy with some of the things they say at times.

The best bet is to go directly to the source of the action and put yourself right on the inside of things. Just make sure you do this safely, so you get in anybody's way. This is an art, aided and abetted by the use of a communications receiver and/or a scanner. With such devices, you can effectively go right to the "front lines" to hear what those who are grappling with solutions to the problems are saying to one another. That not only gives you the full and unadulterated story, it provides you with information often hours ahead of the news media.

This is why it is vitally important for every concerned citizen to be armed with communications gear. It's as vital as any other provisions or techniques you may have established to let you cope with emergencies—a cache of food and water, medical supplies, perhaps weapons. Without the ability to listen in on what's going on around you, you're existing in (and, what's worse, operating in) what is essentially a vacuum. This is definitely not a good way to approach your safety and survival, or that of your family.

Look to the military for a role model. Do you think a modern military force marches, sails, or jets off into battle without paying attention to what's being said over numerous communications frequencies? It's called COMINT in the trade—*communications intelligence*—and it's one of the most effective ways the military has of finding out what's really going on behind the scenes, above and beyond the official dispatches. All you need to do this is the equipment and some savvy on what to listen for and where to tune.

For instance, right now the in-vogue approach to national civil defense calls for massive evacuations of various portions of the populace. Without making any value judgments on the possibilities of moving the population of San Francisco into the mountains, or 8 million New Yorkers (together with their 8 million stories) to the wilds of New Jersey, Connecticut, or Long Island—let's just say that things come to the point where such a scheme is set into motion. State police are going to have every one of their frequencies going full tilt, auto emergency channels are going to be wall-to-wall with stations, highway maintenance frequencies will have activity as never before, and so on. Now if you were about to embark upon a trek as part of this national program (and you may not





Civil insurrection or breakdown of law and order activates medical, National Guard, civil defense, and many other channels.

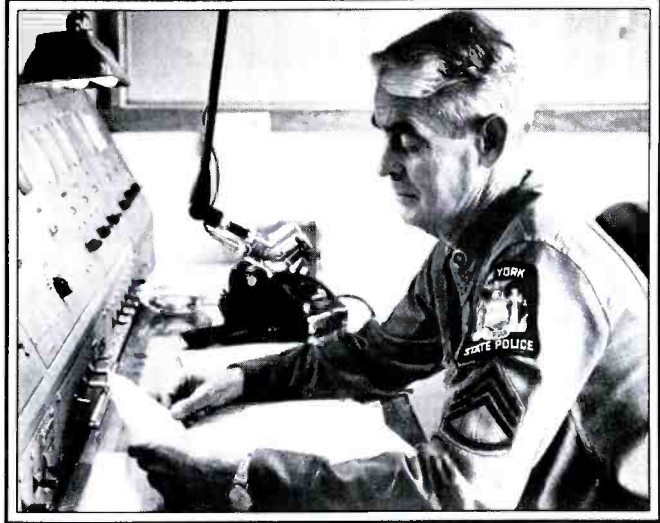

If the current plans for mass evacuations ever get put into effect, you'll want to monitor state police and highway maintenance frequencies, as well as those used on parkways, turnpikes, bridges, and other vehicular facilities.

have the option of *not* going), think of how much information you could get in a hurry on road and traffic conditions at various locations if you could tune in on the conversations of those attempting to keep the caravans rolling towards their destinations.

Let's say that a tornado has sliced a swath through your county; it has knocked out your local broadcasting station as well as crumpled in the NOAA VHF weather station on 162.55 MHz that you've been depending upon. What do you then do for weather and other necessary information? One approach is to tune your communications receiver to a clear-channel broadcasting station in another community. There are more than 100 such stations in the United States and Canada and you can hear them 'round the clock. You can get your up-to-the-minute weather information by zeroing in on one of the 96 low frequency weather broadcast stations operating below the broadcast band between 194 and 400 kHz. These stations can be picked up on most communications receivers and their signals are available in most parts of the nation. Most people don't even know about them!

Flood coming your way every Spring? *Bingo!* You can tune in on the U.S. Army Engineers, as well as your state Civil Defense, the Red Cross, flood control networks, and the highway maintenance stations. *That* puts you in the know far better than anything else you can try.

Surviving in the backwoods? How about enhancing your chances of doing it successfully by monitoring state and federal forest fire towers, fish and game wardens, and the frequencies used by logging companies and even area ranchers?

Civil unrest? Urban riots? The streets are seething with hordes of looters and cut-throats; the National Guard has been called in to help make the streets safe. But where are they? Are they in your neighborhood? Are they having any luck? Are they getting reinforcements? Are they pulling back to re-

group? Being tuned in on their operations is a definite plus in your efforts to survive.

Major national crisis? Military alert? All local broadcasters are put under orders to cease transmitting. Are you in a news vacuum? No way! You have the equipment on hand to tune military communications frequencies to get status reports, and you can monitor numerous shortwave broadcasters around the world transmitting English Language news.

Without leaving the confines of your home, apartment, or hideaway in the backwoods, you are plugged into your community and even the world! You are able to place your fingers on the pulse of the situation and make a diagnosis far more accurately and rapidly than by any other means. Your ability to monitor even outweighs your need to have reliable two-way communications.

Getting It All Together

First, you'll need a scanner. You can select from any number of different models now available from several manufacturers. These days there are models to suit any wallet and operating requirements. You'll want a decent communications receiver too, one that tunes down to 200 kHz or lower. And make certain that it can receive single sideband, since that's the mode used for most non-broadcast voice transmissions between 1600 kHz and 30 MHz. Digital frequency readout is a handy feature since it makes zeroing in on a desired frequency a cinch.

You'll also want to consider the possibilities of obtaining portable communications equipment since you may want to monitor things while you're on the go—either by foot, boat, or vehicle. Scanners and communications receivers are available in portable form and they should be seriously considered for use by those who view monitoring as having more of a potential than listening for fun and relaxation (not that I have anything against that during "quiet" times).

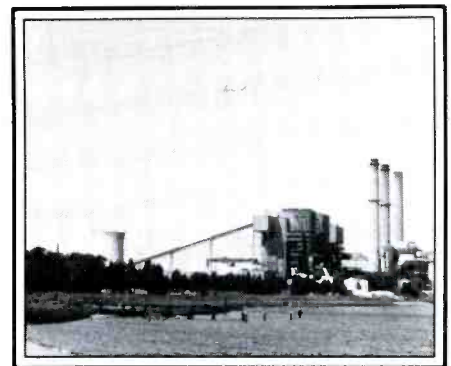

Nukes seem especially prone to accidents, which cause inconvenience to all who happen to live within range of their radioactive pollution. Other radiations, however, are of vital interest to scanner owners—and these are transmissions from Nuclear Regulatory Agency personnel, civil defense, state police, and a myriad of others. You'll certainly want to hear what they have to say.

Next, the matter of where to listen for what you want to hear. You can assemble frequencies from many different sources, keeping a registry of the vital and important ones for your use.

I'd say that the handiest and most concise way of gathering this data and having it available at your fingertips for instant use is by obtaining a copy of a book called *The National Directory of Survival Radio Frequencies*. Here, between the book's covers, are 5,000 of the most vital frequencies you'll want, including (to name only a few): national disaster frequencies; search and rescue; English Language shortwave broadcasts beamed to North America; U.S. Fish and Wildlife Service channels; National Park Service frequencies; military and NORAD; frequencies that can be used for auto emergency, ranchers/farmers, hospitals/EMS, Army Engineers, the Nuclear



Major disaster? Explosion? Nearby aircraft crash? Your life could easily depend upon the decisions made by emergency crews! That's why it is important for you to monitor them while those decisions are being made.



Floods? Hurricanes? Twisters? Ho boy, do the communications channels buzz with high activity. Anybody living in areas where natural disasters take place with any regularity would be wise to keep an ear peeled for what's taking place behind the scenes with those who spot these things coming, and who clean up after they've gone.

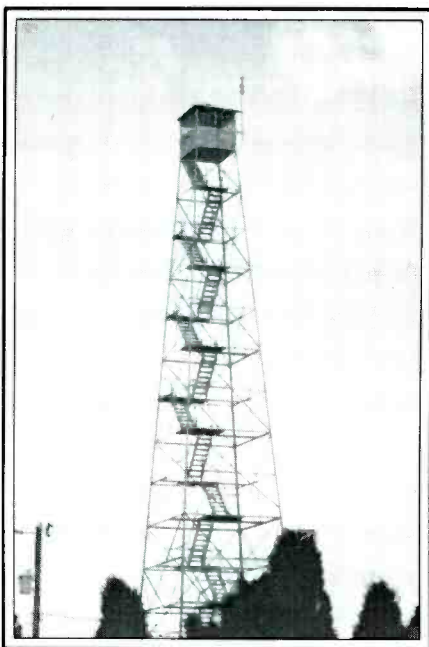

Forestry conservation stations offer plenty of useful information to persons living outside of metropolitan areas, and even though frequency data on them has (until now) been hard to come by, they are worth monitoring for important information.

Regulatory Commission, and logging companies. A complete list of U.S. and Canadian clear channel broadcast stations is presented, as well as a detailed listing of all low frequency continuous weather broadcast stations (194 to 400 kHz).

State-by-state listings cover state police and highway patrol frequencies (base, mobile, repeater, and relay), state civil defense, highway maintenance, Air and Army National Guard, alcoholic beverage control, game wardens, state prisons, Indian reser-

vations, forestry (forest fire towers), turn-pikes and parkways, ports/harbors/bridges, and all sorts of other shortwave and scanner frequency communications. Actually, the book encompasses 179 kHz to 470 MHz and is indexed for easy use. It's a book for all survivalists and, in fact, any concerned person wanting to have a great amount of vital frequency data concentrated into one easy-to-use and concise directory.

This is a new book and should easily become the standard reference guide to monitoring a wide, all-band spectrum of emergency frequencies. *The National Directory of Survival Radio Frequencies* is available at leading communications and survival supply dealers. It can also be obtained by mail if you can't find it in a local store. To order by mail from its publisher, send \$6.95 to CRB Research, P.O. Box 56, Commack, NY 11725. If you want your book sent to any address (U.S./Canada/APO/FPO) by faster First Class Mail, include an extra \$1 (total \$7.95). Outside North America, add \$2 for Air Mail.

By the way, the highway maintenance and state forestry frequencies have thus far been "unlisted" in any popular monitoring guides, even though they provide valuable (and exciting) communications at times, including emergency weather transmissions! These listings alone would make this book more than worthwhile, even if it contained no other information!

All Ears

You're in tune with your surroundings now, and you have all you need at your disposal. Your scanner and communications receiver have made you an information "insider," with first-hand news bulletins before the news media receives them, modifies them, and then gets around to sending them out to the public. You'll know things ahead

of your neighbors, and keeping ahead is the name of the game, isn't it?

And here's a thought for those of my readers who use a scanner and communications receiver strictly for hobby purposes. Remember that there aren't many hobbies that can be made to do double duty for some practical purpose; your hobby is one of the few! Try that with a stamp collection, or a cabinet full of scrimshaw! Think about it!

TL 3

TACTICAL LIBRARY SERIES

NATIONAL DIRECTORY OF SURVIVAL RADIO FREQUENCIES

BY TOM KNEITEL, K2AES

5,000 LISTINGS 179 KHZ TO 470 MHZ



CRB RESEARCH
P O BOX 56
COMMACK NY 11725

I found this book to be a spectacular collection of 5,000 vital emergency communications frequencies between 179 kHz and 470 MHz, especially those rare highway maintenance and forestry conservation channels that (for some unknown reason) never seem to be made available to the public.

... from the publishers of **CQ**

You be the judge...

Here's what you've been looking for – an all new hard-hitting monthly magazine which gives a unique insider's view of what's really going on in the world of communications. **POP' COMM** is your primary source of information – bigger and better than any communications magazine, with exciting coverage of scanners, shortwave broadcast & utility stations, spy stations, pirate and clandestine broadcasters, RTTY monitoring, survivalist communications systems, FCC news, wiretapping and bugging, voice scrambling/unscrambling, surveillance/undercover communications, satellite & cable TV, sophisticated telephones, & more. What you've been looking for all along! Take advantage of substantial savings over the newsstand price by subscribing now. Don't miss out on even one single issue of **POPULAR COMMUNICATIONS** – order your subscription now.

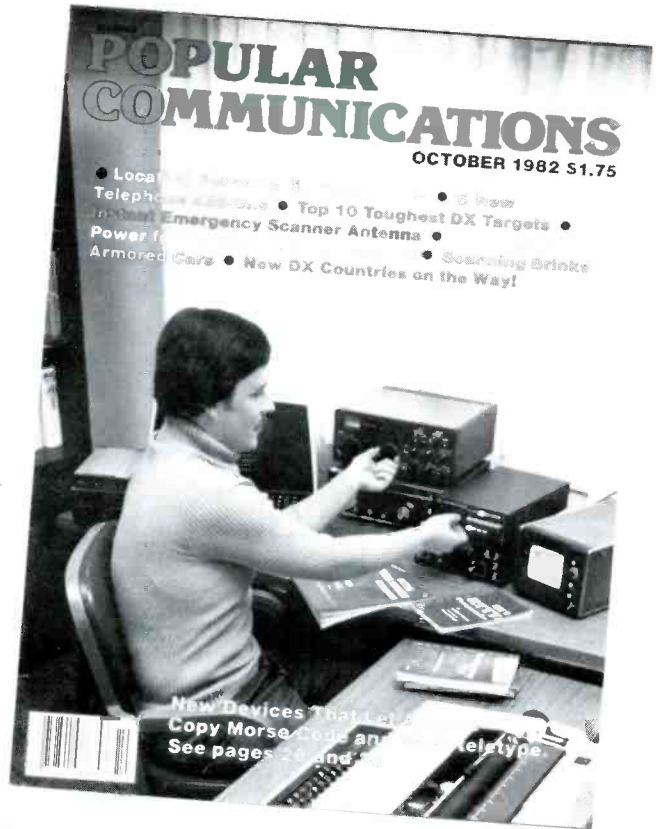

Twelve Issues \$12.00

SUBSCRIBE NOW & SAVE!

POPULAR COMMUNICATIONS 76 N. Broadway, Hicksville, NY 11801

Yes! The **NEW POPULAR COMMUNICATIONS** is just the magazine I've been looking for. Start sending it to me now! I understand that I may cancel at any time for any reason, and receive a full refund on my unused subscription.

Paid by: Check Money Order MasterCard Visa
My account number is:

--	--	--	--

Name _____
Street _____
City _____ State _____ Zip _____

- 1 Year (12 issues) \$12.00
Newsstand price \$21.00
- 2 Years (24 issues) \$22.00
Newsstand price \$42.00
- 3 Years (36 issues) \$32.00
Newsstand price \$63.00

Canada/Mexico — one year \$14.00, two years \$26.00, three years \$38.00; Foreign — one year \$16.00, two years \$30.00, three years \$44.00; Foreign Air Mail — one year \$69.00, two years \$136.00, three years \$203.00.

PRODUCT SPOTLIGHT

Towards A Fully Secure Telephone



The Problem

Protection of sensitive telephone conversations from eavesdropping.

Existing Solutions

1. *Telephone Tap Detection*—Technical evaluation of a telephone to detect parameter changes caused by the application of the tap.

- Voltage and current changes.
- Reflectometer echos.
- RF detection of tap transmitters.

2. *Voice Scramblers*—The alteration of voice sounds to make them unintelligible to the listener. The application of scramblers does not attempt to detect or prevent tapping; rather, it attempts to make unusable that which is recovered from the tap.

Capabilities And Limitations Of Existing Solutions

1. *Telephone Tap Detection*—The effectiveness of each of the three types of telephone tap detection depends, of course, on the type of tap. In any event, any technical evaluation is limited to the line being evaluated; i.e., discovering a tap on the telephone line between the telephone exchange and the telephone terminating the line being evaluated. The circuitry within the telephone exchange prevents examination of the remote party's line from the calling party.

a. *Voltage and Current Changes*—This approach will detect series transmitter taps and low- and medium-impedance direct taps and voltage-operated recorder-starters. It will not detect high-impedance taps, since the changes affected in line parameters caused by a high-impedance tap would be less than the normal variations in the telephone-system voltage and current values.

b. *Reflectometer Echos*—A reflectometer sends a pulse down the telephone line, which sends back an echo when an aberration is encountered. In theory, even a change in wire size is sufficient to cause an

The Masque—BSL can be used with a single-line phone, and The Masque—BML can be used in conjunction with a multi-line hook-up.

echo. The returned echo(s) is plotted on a time-base line allowing the determination that an aberration exists and approximately how far away it is. Unfortunately, there are many echo-producing junctions along the telephone line. Discrimination is usually insufficient to categorize an echo as a tap, rather than a legitimate junction. Moreover, taps are not normally emplaced by cutting into the cable between junctions; normally, they are emplaced at existing junction points, where access to the line is practicable. Discrimination between a junction alone and a junction with a tap added is seldom possible.

The reflectometer pulse will not penetrate an in-line loading coil, which means that that portion of the line between the loading coil and the exchange is unchecked.

The effectiveness of the reflectometer is generally considerably lower than voltage and current change measurement.

c. *RF Detection of Telephone Tap Transmitters*—Tap transmitters located in the subject telephone or in the telephone line near the telephone can be located by standard RF sweep techniques, providing the telephone is in use during the sweep. By connecting the RF receiver or spectrum analyzer directly to the telephone line, tap transmitters located down the line can be detected. (Series transmitters can be detected faster by voltage measurements.)

2. *Voice Scramblers*—The major advantages of voice scramblers lie in that they perform their function regardless of the type of tap and irrespective of whether the tap is on the calling line or the called line. Since their function is to scramble, assuming that their security level is satisfactory, there is no requirement for attempting to locate a tap.

The first disadvantage is that the called party must possess a comparable scrambler.

Thus, no security is provided except for those calls made to a previously selected telephone (or individual, in the case of a portable scrambler), which has been equipped previously with a mating scrambler. In theory, identification can be made of called parties with whom sensitive conversations are expected and, without regard to expense, scramblers can be provided for them. In actual practice, there will be telephone calls to other parties that will contain portions of the sensitive information which, when examined cumulatively, may provide the total.

The second disadvantage of the scrambler lies in the trade-off between effectiveness and price. While there are almost as many different level-evaluation methods as there are manufacturers, a simple delineation is low-, medium-, and high-level. These levels refer to the difficulty by someone, other than the intended recipient, of unscrambling the scrambled voice. It must be borne in mind that the unscrambling effort is not limited to a one-shot attempt. Once the scrambled conversation has been taped, it is available for as many experiments as may be desired to attempt to unscramble it.

Low-level scramblers are simple frequency-inversion systems. These constitute the bulk of the scramblers offered. They are defeated by a technically simple and well-known process which is equally effective on all scramblers of this type, whatever "code" may have been used in the scrambling. Determining the setting the "code" requires only a few seconds. These scramblers are more properly referred to as privacy systems and are useful when the threat is an attempt to eavesdrop from an extension telephone.

Mid-level scramblers provide at least an order of magnitude more security than low-level scramblers. Sophisticated design tech-

niques promise that high technical skill and, probably, considerable time will be required to unscramble the conversation.

High-level scramblers are designed at a level of sophistication to make them virtually unbreakable. Generally, breaking them would require months or years of computer-assisted effort. From a security standpoint, the high-level scrambler is the obvious choice. Unfortunately, they cost between \$15,000 and \$20,000 each. This generally mitigates against providing them for any but the most critical needs.

3. *Summary of Capabilities and Limitations*—The use of medium- or high-level scramblers provides effective protection against eavesdropping on those conversations made to a remote telephone previously equipped with a compatible scrambler. It provides no protection for any other calls.

Tap detection techniques are effective against many (perhaps most) types of taps. They provide their effectiveness against taps placed on the subject line, not on the line called (unless, of course, the remote party has had his line similarly checked). The protection provided is historical in nature. Until the next check of the lines, taps applied subsequent to this check will not be discovered.

It appears obvious from the above that existing solutions to the problem of protecting telephone conversations from eavesdropping leave several security holes. The scrambler provides no protection for other than those calls to pre-selected locations that have been equipped with compatible scramblers. Both expense and the ability to foresee each future requirement seriously limit the comprehensiveness of this approach. While tap detection techniques are effective for many types of taps, they are completely ineffective for some. If the eavesdropper selects a tap and location for the tap that makes the tap undetectable, the security is zero. Also, tap detection techniques do nothing for a tap emplaced after the line check.

Additionally, future developments in either of these two areas are unlikely to overcome the stated problems, since the problem with scramblers is getting a compatible unit at each location where a sensitive call may be made and the problem with detection is the lack of absolute uniformity of the telephone system.

The Masque

Several years ago, Dektor began looking into this problem area with the objective of reducing the problem. The developed research guidelines which pertained were:

a. No system could be affected that would make the conversation unintelligible at both the subject end and the remote end. The remote party would have to have been previously equipped, and this could not be done without the remote party being able to understand the conversation.

b. Only by making the conversation unintelligible would there be assurance that a tap could not be exploited.

The logical summation of these two guidelines resulted in an objective for devel-

opment of equipment which would make conversation acquired by tapping the subject's telephone lines unintelligible, but would be clearly intelligible at the remote telephone.

An assessment of the security value of such a development was sufficiently satisfying. Where the perceived threat would be the tapping of both the subject telephone line and the remote telephone line, based upon the eavesdropper's perception of the remote party's likelihood of receiving sensitive calls from the subject telephone, the scrambler approach would be appropriate. For all other applications, the result of successful accomplishment of the aforementioned would provide the best solution.

Once a developmental approach was perceived and tested, it became obvious that no one single technique would fulfill all the requirements for all tapping techniques. Consequently, this development, named The Masque, ultimately became an integrated system of developments.

From a results point of view, The Masque prevents the interception of the telephone conversations from the subject telephone line by high-, medium-, or low-impedance direct taps, surveillance amplifiers, tape recorders, and either series or parallel transmitter taps. The interception, when The Masque is switched in, will receive either broad-band noise or dead silence, while the legitimate parties to the conversation proceed virtually without interference.

Unlike the scrambler, a tape recording of the tap is not useful in repeated attempts to break the system.

Displayed on the face-plate of The Masque are indicators for the four functional sections of The Masque system, providing a constant check of the total system functioning.

The Masque provides an output, in addition to the normal conversation, which, while it will neither damage telephone equipment nor interfere with exchange operation, is not in compliance with FCC regulations. Consequently, its use on other than private or proprietary systems may be a technical violation of regulations.

Dektor Counterintelligence and Security is located at 515 Barnard St., Savannah, GA 31401.

SATELLITE TV SYSTEMS

"COMPARE OUR QUALITY, PRICES, AND SERVICE!"

WE MANUFACTURE:

Parabolic Dishes	Motorization Systems
Polar Mounts	LNA Holders
Demo Trailers	Aluminum Horns

WE STOCK:

Drake	Blonder Tongue
Washburn	KLM
Auto Tech	MFJ
Amplica	Gillaspie
Avantek	Scientific Atlanta
Chaparral	Alliance U-100 & HD-73
Avcom	

Modulators, Switches & Hardware, Cable & Connectors

AUSTIN C. LEWIS LEWIS CONSTRUCTION CO.

P.O. BOX 100

901-784-2191

HUMBOLDT, TN 38343

"IN BUSINESS AT THIS LOCATION SINCE 1964"

Call Or Write For Our Latest Brochure and Prices.

CIRCLE 38 ON READER SERVICE CARD

MFJ SHORTWAVE ACCESSORIES

NEW Indoor Tuned Active Antenna. Rivals, can even exceed reception of outside long wire.

Rivals long wires

\$79⁹⁵

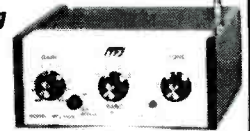

MFJ-1020 NEW INDOOR ACTIVE ANTENNA sits on your desk ready to listen to the world. Rivals can often exceed reception of outside long wire. Unique Tuned Active Antenna minimizes intermod, provides RF selectivity, reduces noise outside tuned band. Also use as preselector for external antenna. Covers 300 KHz to 30 MHz in five bands. Adjustable telescoping antenna. Controls: Tune, Band Selector, Gain, On-Off/Bypass, LED, FET, bipolar circuitry. Phono jack for external ant. 6x2x6 inches. 9-12 VDC or 9 V battery for portable use. 110 VAC with optional AC adapter, \$9.95.



\$99⁹⁵

MFJ-1040 RECEIVER PRESELECTOR. Improves weak signal reception, rejects out-of-band signals, reduces image response. 1.8 to 54 MHz. Up to 20 db gain. Low noise MOSFET. Gain control. Bandswitch. Can use 2 ant., 2 rcvrs. ON-OFF/Bypass. 20 db attenuator. LED. Coax, phono jacks. 8x2x6 in. Also for XCVRS to 350 watts input. Auto bypass. Delay control. PTT jack. **MFJ-1045, \$69.95.** Same as MFJ-1040, less attenuator, xcvr auto bypass, delay control. PTT. Use 1 ant., 1 rcvr. 5x2x6 in. 9V bat. Both requires 9-18 VDC or 110 VAC with optional AC adapter, \$9.95.

\$99⁹⁵



MOBILE SWL CONVERTERS to hear the shortwave world while you drive. **MFJ-304** (\$79.95) covers 19, 25, 31, 49 meter bands. **MFJ-308** (\$99.95) adds 13, 16, 41, 60 meters. Two dual-gate MOSFETS give excellent sensitivity, selectivity with car receiver. Push button band selector. Tune with car radio. Plugs between antenna and radio. 12 VDC. **304** is 5 1/4x1 1/4x4". **308** is 6 1/4x1 1/4x5". **Free catalog.**

MFJ-10, 3 foot coax with connectors, \$4.95.

Order from MFJ and try it. If not delighted, return within 30 days for refund (less shipping). **One year unconditional guarantee.**

Order yours today. Call toll free 800-647-1800. Charge VISA, MC. Or mail check, money order. Add \$4.00 each for shipping and handling.

CALL TOLL FREE ... 800-647-1800

Call 601-323-5869 for technical information, order/repair status. Also call 601-323-5869 outside continental USA and in Mississippi.

MFJ ENTERPRISES, INCORPORATED
Box 494, Mississippi State, MS 39762

CIRCLE 75 ON READER SERVICE CARD

RADAR REFLECTIONS

RADAR DETECTORS AND THEIR USE

BY JANICE LEE

Manufacturer Sues District Of Columbia & DC Officials

Electrolert, Inc., the Ohio-based manufacturer of the Fuzzbuster®—a popular brand of radar detector, brought suit against

the District of Columbia and two of its officials, Mayor Marion S. Barry and Metropolitan Police Chief Maurice Turner. Along with the co-plaintiffs, Poptronics Electronics, Inc., a Maryland retailer, and George Sadler, a Maryland radar detector owner, Elec-

trolert is seeking injunctive relief. They are challenging D.C. Commissioners' Order #61-2026, which prohibits simple possession of any device that can detect police radar and the use or sale of such devices. Charging that the order is unlawful, discriminatory, and arbitrary and is in direct violation of the Commerce Clause and other provisions of the United States Constitution, the plaintiffs are seeking a declaratory judgment to restrain the defendants from enforcing it.

The plaintiffs cite the Commerce Clause, the Supremacy Clause, and the Due Process Clause of the U.S. Constitution as the basis for their action. The Commerce Clause, which is contained in Article I, Section 8 of the Constitution, restricts any legislative activity which impermissibly interferes with interstate commerce. Radar detectors may be legally purchased and used in virtually all other jurisdictions of the country. By disallowing such activity in the District of Columbia, including even simple possession of such equipment by an out-of-state motorist passing through the District, the plaintiffs claim that the Commissioners' Order is in violation of the Constitution.

The Supremacy Clause, which is contained in Article VI, Clause 2 of the Constitution, helps protect the public's access to the airwaves by preempting any state legislative activity in the area of radio reception where the federal government has assumed a pre-eminent role. A radar detector is a device that is tuned to the X-band and K-band frequencies used by police traffic radar and as such is a radio receiver. In the Communications Act of 1934, Congress remanded authority over all radio transmission and reception to the Federal Communications Commission. The FCC has specifically addressed the issue of radar detection devices and, as late as 1980, has failed to introduce legislation which would prohibit their use. The complaint also contends that the Order violates the Due Process Clause of the Fifth Amendment because it is vague, overbroad, arbitrary, and capricious.

In the complaint filed in the United States District Court, Electrolert charges irreparable harm from loss of sales and that it "... has no adequate remedy at law due to the actual and threatened arrests pursuant to the Commissioners' Order." The company states that the action is brought "... to vindicate its own interests and the interests of its actual and potential customers who have been injured ...".

As co-plaintiff in the suit, Poptronics also claims irreparable harm. Citing the broad application of the Commissioners' Order, which prohibits the sale of "any device" which is designed in such a way as to be able



to "detect or counteract police radar," Poptronics charges that it has suffered from the loss of potential sales of other radio equipment such as CB radios, Amateur radios, and other broad-band radio receivers, as well as radar detectors. This point of law has been one of the key issues leading to the defeat of radar detector prohibitions in more than 30 state legislatures. Proper enforcement of such a law has been deemed difficult, if not impossible. As the suit also points out, the FCC has licensed for industrial and private use numerous other microwave devices on the same frequencies as the Metropolitan Police Department and the Commissioners' Order, in effect, also prohibits the sale or use of these.

George Sadler, a Maryland resident and the third plaintiff, frequently travels through the District of Columbia during his interstate travels of a business nature. Although the use of radar detectors is perfectly legal in Maryland and in most other states, Mr. Sadler was arrested for simple possession of a radar detector while passing through the District in 1981. Mr. Sadler's contentions bolster the claim that the order improperly interferes with interstate commerce and therefore abrogates Constitutional guarantees.

As part of their factual contentions, the plaintiffs cite the scientific documentation which demonstrates the unreliability of police radar—fallibilities that are worsened by congested urban traffic such as found in the District. The complaint also notes that radar detectors may be sold legally in 49 states and that the Commissioners' Order is the only one in the nation that prohibits simple possession as opposed to the use or installation of radar detectors. In other legal forums, such contentions have demonstrated that restrictive state laws violate due process and other constitutional requirements.

In their request for relief from the federal court, the plaintiffs have asked the court to issue a judgment declaring the Commissioners' Order unconstitutional and illegal based on its violations of the constitution. Other requests include an order for the defendants to return to Plaintiff Sadler the radar detector confiscated from him along with a \$50 fine he paid, and to award the plaintiffs their costs and disbursements as provided for by federal law.

Since its inception in 1975, Electrolert, Inc. has spent over \$1 million in legal fees to successfully defeat radar detector bills at the state level, to institute judicial proceedings on behalf of individual motorists, to counter rulings such as the District of Columbia's, as well as institute legislation which calls for minimum performance standards for police radar. In the past two years, the company has been responsible for rendering a prior Virginia radar detector law unenforceable and was instrumental in the introduction of a strict standard for police radar equipment and training in the State of Florida, both well-publicized cases favoring the motorist.

Janice Lee is the Editor of MONDAY, A.M., the newsletter of Electrolert, Inc.

NRI will train you at home to be an electronics professional in the growing world of communications.

Learn to service, repair, and install everything from microwave antennas to two-way radios... from radar sets to TV transmitters.

No other home-study course gives you such complete, professional training in so many fields of communication. No other gives you such advanced equipment, selected for state-of-the-art design and features. Only NRI gives you the thorough preparation and training you need to achieve professional competence in the wide world of communications.

Learn at Home in Your Spare Time

Learn at your own pace, right in your own home. There's no need to quit your job or tie up your evenings with night classes. No time or gas wasted traveling to school: NRI brings it all to you. You learn with NRI-developed fast-track training methods, a clearly and logically organized program using advanced techniques for learning at home.

Includes 2-Meter Transceiver or Bearcat Automatic Scanner

Your training is built around your choice of this high technology equipment. The synthesized two-meter transceiver represents the latest advance in portable communications. Microprocessor-based



Train with professional instruments and equipment that's yours to keep.



Microwave



CB Radio



Marine Communications



TV Broadcasting



AM & FM Broadcasting

circuitry and LED digital readout mean precision operation and high efficiency. The scanner also features microprocessor basing with both programmable and scanning functions covering the HF, VHF, and UHF mobile bands. Using NRI Action Audio cassette training units, you learn not only how to operate these units, but study their advanced circuitry in detail.

Also included for both training and professional use is a six-function Beckman LCD digital multimeter, a Heathkit portable frequency counter, the NRI Antenna Applications Lab, and the NRI Discovery Lab,® where you build and test the "leading-edge" circuitry found in your transceiver or scanner.

FCC License or Full Refund

In addition to all lessons, equipment, and instruments, you get special training for the FCC radio-telephone license you need to work in this exciting field. You pass your FCC examination or *your tuition will be refunded in full*. No ifs, ands, or buts...this money-back warranty is valid for six months after completion of your course.

Free Catalog, No Salesman Will Call

NRI's free 100-page catalog shows all the equipment you get, describes each lesson in full, and tells about other electronic training in fields like TV/Audio/Video, Microcomputers, and Digital Electronics. Mail the coupon and see how we can make you a pro. If coupon has been removed, please write to NRI Schools, 3939 Wisconsin Ave., Washington, D.C. 20016.



NRI Schools
McGraw-Hill Continuing
Education Center
3939 Wisconsin Avenue
Washington, D.C. 20016

We'll give you tomorrow

NO SALESMAN WILL CALL

Name _____ (Please Print) Age _____

Street _____

City/State/Zip _____

Accredited by the Accrediting Commission of the National Home Study Council



Please check for one free catalog only.

- Communications Electronics • FCC Licenses
 - Mobile • CB • Aircraft • Marine
- Color TV, Audio, and Video System Servicing
- Electronics Design Technology
- Computer Electronics including Microcomputers
- Digital Electronics
- Basic Electronics
- Small Engine Servicing
- Appliance Servicing
- Automotive Servicing
- Auto Air Conditioning
- Air Conditioning, Heating, Refrigeration, & Solar Technology
- Building Construction

All career courses approved under GI bill.
 Check for details.

76-122

NEW AND EXCITING TELEPHONE TECHNOLOGY

Phone Home . . . Phone Home

Cordless telephones are fast becoming standard equipment in households throughout the United States. Businessmen are no longer tied down to their desk when they switch to a cordless telephone and roam their office areas. Take your phone with you and never miss a call when you visit your neighbor's house or shop at the market at the end of the block. Cordless telephones are cutting the hard-line connection between you and your telephone apparatus.

It was more than five years ago when the ROVAPHONE® cordless telephone was introduced to the American public. At \$500 each, there were few takers. Nonetheless, it was indeed intriguing that you could easily tie in your home telephone to a full talk-and-listen telephone without the use of wires. The ad pictured a pretty girl by a pool with her phone setup, and these early sets actually worked quite well.

First generation cordless telephones operated on CB R/C channels at 27 MHz to and from the base transponder. Then the cordless apparatus transmit frequency was changed to 49 MHz. This 22 MHz spread in transmit and receive frequency made it quite easy to offer full-duplex (talk and listen) with up to one mile range.

About three years ago, the FCC ruled out any further production of cordless telephones that used 27 MHz for one side of the conversation. A new frequency band was created at 1.7 MHz for the base transponder unit to send out signals to the cordless telephone equipment. The talk-back frequency from the cordless phone remains unchanged at 49 MHz.

This 48 MHz split in the two frequencies also made duplexing the equipment easy. However, one major drawback to this new frequency plan was the amount of noise at 1.7 MHz, as well as the reduced range of the transponder to the hand set at 1.7 MHz. The 1.7 MHz telephone-side signal would be transmitted into the household AC wiring, and depending on how your house or building was wired, you might enjoy exceptional range, or just barely enough range to meet the advertised specifications of 600 feet.

Cordless Telephones Today

Within three years, Japan has literally flooded the market with quality 1.7 MHz/49 MHz cordless telephones. There are over 20 companies offering cordless telephone sets. In reality, these companies are simply privately labeling a variety of about 10 different Japanese cordless telephone models. Only a few U.S. companies truly make their own cordless telephone with no look-alikes here in the United States.

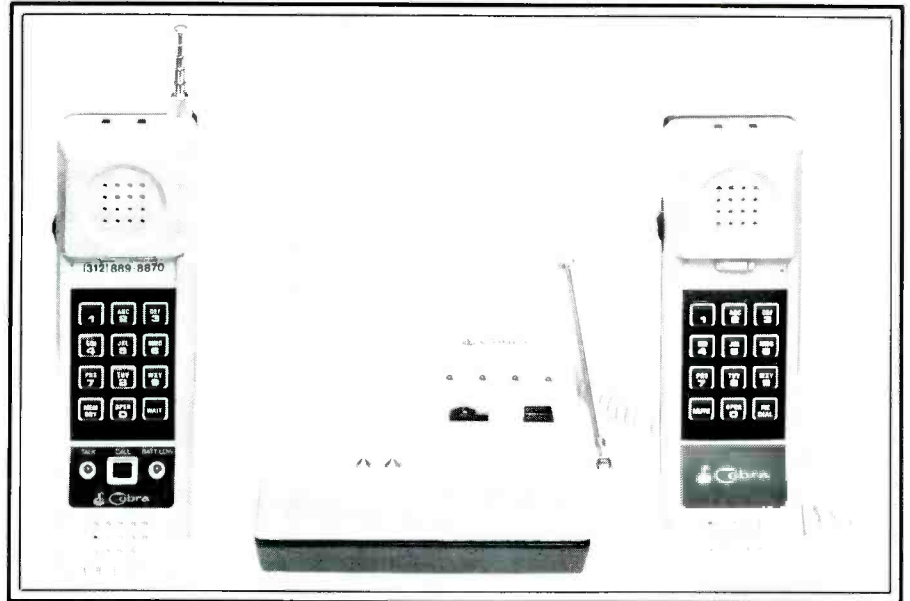

Cobra Model CP-140S Telephone System from Cobra Communications Product Group of Dynascan Corp., consisting of: (1) Model CP-120S Cordless Phone; (2) Model CP-141S Wired Phone; and the (3) Model CP-120B Base Unit.

The modern cordless telephone will allow users to travel up to approximately 700 feet from the base transponder before they reach the edge of their communications range. Installation is easy. Plug the base transponder into a convenient wall socket, pull up the antenna, and attach the telephone line to the base set. Modern telephone connectors allow everything to plug right in to the wall without any modification.

To place and receive phone calls, simply pick up the cordless hand set and turn it on. When a phone call is incoming, the set will sound off. Switch it to "talk" and enjoy regular telephone-like conversation. Rarely will the party at the other end know that you are on a cordless hand set. When the call is completed, switch the set back to the "ready" position.

To place a phone call, simply turn the set to "talk" and key-enter the phone number you wish dialed. Depending on the type of set you have, this keyboard entry procedure will send out tone signals that will either tone-call or rotary pulse-dial your telephone equipment. Almost all cordless telephones are compatible with tone or pulse dialing.

Cordless Complications

One problem with today's cordless telephone is interference on the hand set. Remember, you are listening to signals at 1.7 MHz through your home wiring. Your transmitted signals at 49 MHz go directly to the base transponder with few problems. It's the 1.7 MHz receiving link that is weak.

A tremendous amount of interference may reduce your cordless range to a mere 100 feet. This interference could be caused by fluorescent lights, dimmer light circuits, battery chargers, electric motors, digital clocks, and other noise makers plugged into the same wiring that is transmitting the 1.7 MHz signal.

Cobra and Electra Corporations indicate that they have developed new circuits in their equipment that will help reduce the noise problem. Special filters built into their cordless equipment allow a better transfer of energy from the base transponder into the household wiring.

Little can be done on the hand set end of things to increase the reception range of a cordless hand set tuned to 1.7 MHz. A simple loop-stick antenna—similar to that of a small transistorized radio—is used for this side of the conversation. When you reach the end of your reception range, you will find the positioning of the hand set critical to picking up weak signals from the base set. The 49 MHz talk-back side of the conversation is seldom a problem and usually out-distances the reception range.

Several accessory manufacturers have developed line-cord devices to help extend the range at 1.7 MHz. The careful use of a well-elevated extension cord may also extend the range before the signal is encapsulated in metal conduit. Some enterprising and semi-technical cordless enthusiasts have even set up old marine antennas to help transmit 1.7 MHz signals over greater

Bearcat® 210XL Super Scanner

Look what you get with the Bearcat 210XL. Exciting, new spaceage styling. No-crystal, pushbutton tuning. New, 18 channel, 6-band coverage of over 6000 frequencies. And features like 2 scan speeds, Automatic Squelch, Search, and Lockout, Direct Channel Access, Selective Scan Delay. And much more. There's never been a Scanner like the Bearcat 210XL.



"TAKE IT FROM A SMART OPERATOR."

Don Adams
BEARCAT 210XL SCANNER \$229.

THE LOWEST PRICED, FULL-FEATURE, BEARCAT NO-CRYSTAL SCANNER EVER.

Bring home all the real excitement of scanning, and save! Bearcat 160 features a smooth, keyless keyboard for all controls including volume and squelch. Has 5-band, 16 channel coverage. Priority, Selective Scan Delay, Automatic Lockout and Search. And much more. Bearcat is number one in scanning.

"TAKE IT FROM A SMART OPERATOR."



\$189. BEARCAT 160 SCANNER

Electra Electra Company
Division of Masco Corp of Indiana

Add \$7.00 per scanner for U.P.S. ground shipping in the continental U.S. Send your cashier's check or money order to our address below or order by phone if you have a Visa or Master Charge card.

COMMUNICATIONS ELECTRONICS™

854 Phoenix □ Box 1002 □ Ann Arbor, Michigan 48106 U.S.A.
Call TOLL-FREE (800) 521-4414 or outside U.S.A. (313) 994-4444

CIRCLE 80 ON READER SERVICE CARD

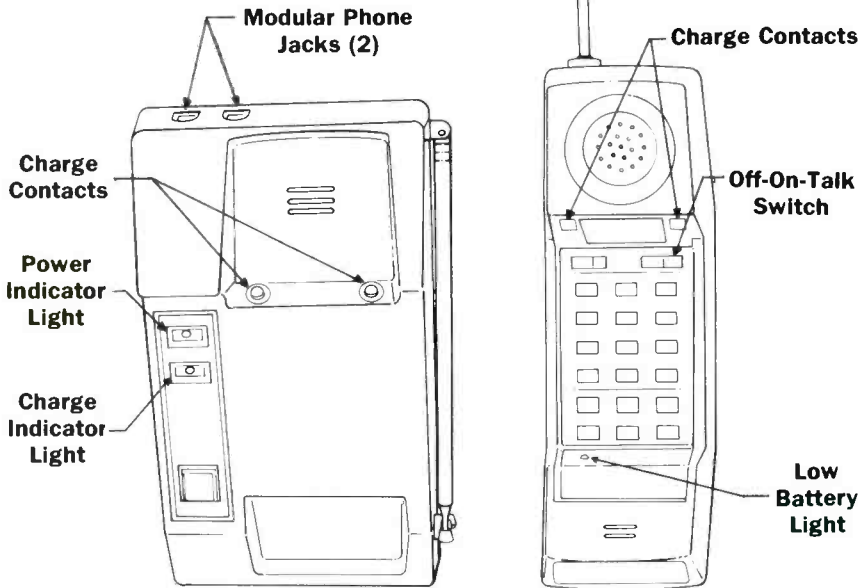

distances than conventional AC wire-coupled techniques.

There are also 49 MHz base reception antennas available on the market that pull in hand set signals up to a mile away. This can cause cordless telephone users to be faced with a new problem.

Wrong Number, Please

The unauthorized use of another person's telephone system is becoming a significant problem. Telephone investigators have discovered a rash of unauthorized calls claimed by cordless telephone users.

"It's easy for kids to find another cordless telephone system. They simply turn their cordless hand set on 'talk' and pedal up and down the streets until they hear a dial tone. It's then a simple matter of wireless piracy of a telephone circuit for long distance calls."

Although manufacturers (actually im-

porters) are slow to admit this problem, we see some changes in new cordless telephone equipment. Since there are only five channels at 49 MHz available for cordless telephone sets, Japanese manufacturers and domestic manufacturers are incorporating digital codes to gain access to a dial tone from only one authorized hand set. Simpler devices lock out the dial tone when the owner's hand set is in the base station cradle for charging.

Outside cordless telephone antennas may also not be 100 percent legal with the FCC, although accessory and antenna manufacturers still contend that they are legal and sell them freely on the market.

Scanning Cordless Calls

Programmable scanners that may tune down to 49 MHz pick up cordless hand set conversations. Although you will only hear

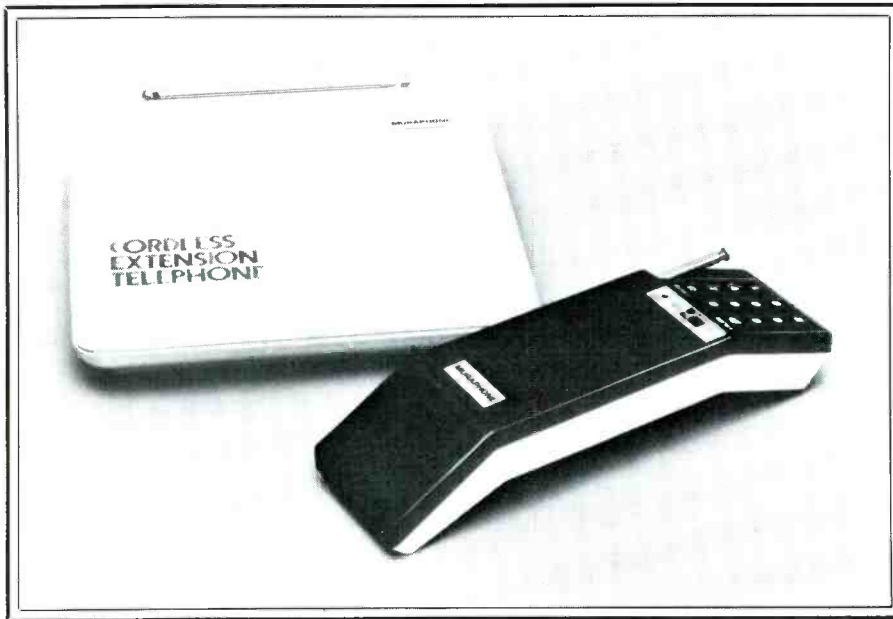

The Muraphone™ MP 600/601 cordless extension telephone.

one side of the FM broadcast, you may find it interesting to monitor. Five frequencies are available for cordless telephones:

- 49.830 MHz
- 49.845 MHz
- 49.860 MHz
- 49.875 MHz
- 49.890 MHz

Emission type: Narrow band FM, 3 kHz deviation.

You will need a communications receiver to tune in the telephone side of the conversation. Using slope detection in the AM mode, carefully tune between 1.650 MHz and 1.800 MHz for base transponder calls. Slope detection will allow you to clarify frequency modulated signals with your AM shortwave receiver.

49 MHz/49MHz Super Range

Electra Corporation—manufacturers of popular *Bearcat*® scanners—has developed a new cordless telephone that operates completely at 49 MHz, full duplex. Using very narrow band techniques and a razor-sharp duplexer, their system operates completely independent of household wiring at 49 MHz two-way.

- Channel 1—49.83 TX hand set
- Channel 1—49.875 TX base unit
- Channel 2—49.845 MHz TX hand set
- Channel 2—49.890 MHz TX base unit

After almost two years of development, the \$400 FF-4000 from Electra truly breaks the range barriers.



Pocket Freedom Phone® 2500 and *Freedom Phone*® 2000 cordless telephones.

When experiments were performed in a residential area with an Electra system (random retail selected unit, Serial No. 13003), range exceeded two blocks from the base unit. Elevating the base unit to the second story gave us a range of almost 1/2 mile on a line of sight basis. Although we are only talking about milliwatts of power, superior receiver design and dual simultaneous circuits at 49 MHz will dramatically increase cordless hand-held range.

Manufacturers are presently vying for additional frequencies near 49 MHz. This is due to the rapidly expanding cordless telephone market.

Cordless equipment today is even more

sophisticated than your actual telephone device. Not only offering portability without wires, modern cordless telephones may offer redialing, memory dialing, call holding, message recorder activation, and a host of other functions from their tiny microprocessor circuits. Cordless telephones are extremely rugged and usually survive a drop or two, too!

If you haven't listened in on a cordless telephone call, or used cordless equipment, you may wish to give it a try. At last we have truly portable equipment that will place a call almost anywhere when you get the word to "phone home . . . phone home . . ." A cordless will do it!

KNOCK OUT IMAGE INTERFERENCE

Now you can tune out strong interfering signals such as mobile phone, aircraft, FM, ham radio or weather band broadcasts and avoid front end overload in your scanner.

The Capri Electronics RF Notch Filter can be used with any scanner that has a Motorola type external antenna jack. No modifications to your scanner are necessary. Works with outside antenna systems as well as with the whip that comes with your scanner.

The easy tune, calibrated dial lets you move the notch to any interfering signal from 70 MHz to 200 MHz. The notch depth is 40 dB at 162 MHz and the VHF insertion loss is less than 1 dB (0.5 dB typical).

Your complete satisfaction is guaranteed. Order your RF Notch Filter today for only \$19.50 plus \$2 shipping and handling.

Mail and phone orders welcome. Send check or money order or we can ship COD. VISA and MasterCard are also accepted. Please include your card number and expiration date. FREE catalog of scanner accessories sent on request.

CAPRI ELECTRONICS
Route 1-G
Canon, GA 30520
(404) 376-3712

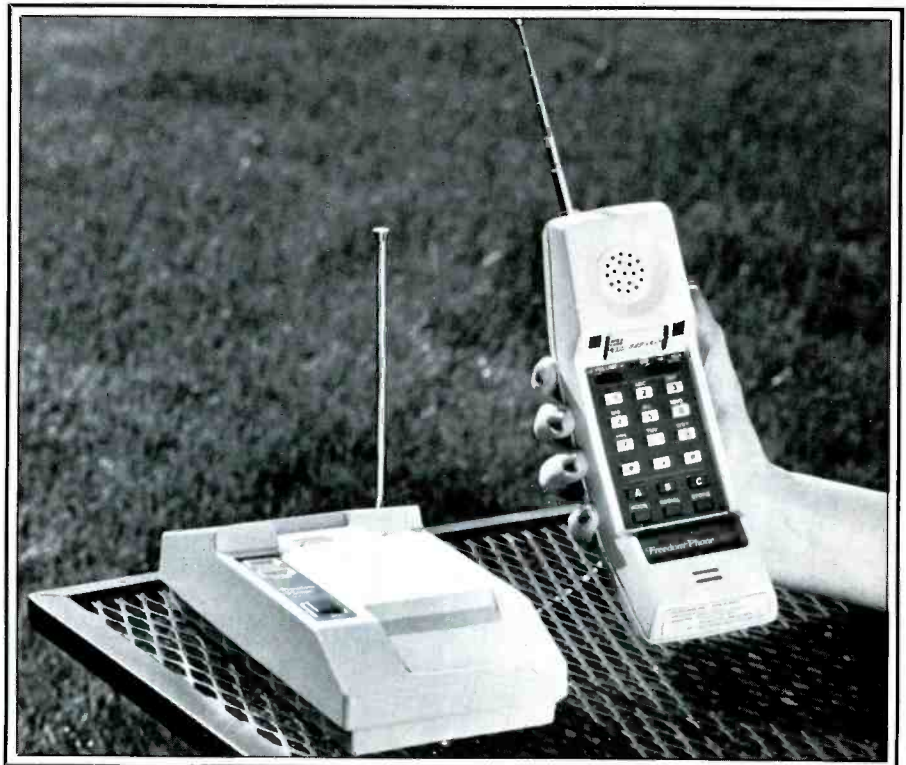

The new 49 MHz Cordless phone.

Controls and Features

1. 117 Vac Power Supply and Cord
2. Antenna - Telescoping
3. Battery Charging Contact - Control Unit
4. Phone Dialing System Switch (Bottom of Control Unit)
5. Antenna Storage Clip
6. Call Button - Used to Page Handset
7. Battery Charge Indicator
8. Electrical Power Indicator
9. Modular Phone Cord (Connection)
10. Optional Phone or Accessory Cord (Connection)
11. Phone Number Plate
12. OFF-ON-TALK Switch
13. Redial Button - Automatically redials last number called
14. Store Button - Use to store number in memory
15. Hook Button - Recalls dialtone - Use to access phone company services where available
16. Microphone (Mouthpiece)
17. Identification Plate - FCC Numbers (Serial Number)
18. Battery - Low Indicator - Handset
19. Automatic Dial Buttons (A, B and C)
20. Keyboard
21. Volume Switch
22. Battery Charging Contact - Handset
23. Speaker - (Earpiece)
24. Antenna - Telescoping

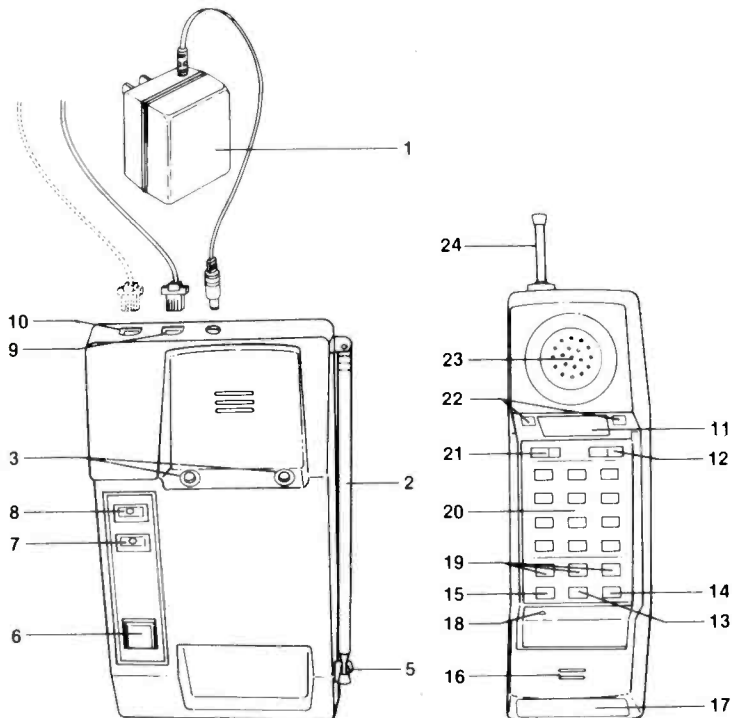

TEL-2500 Talkabout™

This hand-held portable cordless telephone is the TEL-2500 Talkabout™ from Universal Security Instruments. The best way to talk about the new Talkabout is to let its features speak for themselves:

- Exclusive "Hang-Up-Anywhere™" function switches phone from "talk" to "standby" when handset is placed face down on any flat surface. Talkabout handset then rings as a new call comes in!
- Designed for use in and around the house with a range of up to 100 feet.
- Built-in privacy switch for speaking privately to others nearby.

- Two-way duplex operation.
- Phone line "in-use" indicator in base lights if any other phone on same number is in use.
- Includes built-in rechargeable batteries in the handset in use when on base.
- Compatible with all telephone systems—digital or rotary dial.
- Decorator styling.
- Choice of decorator colors.
- Available for \$129.95 (suggested retail price).

For further information, contact Universal Security Instruments, Inc., 10324 S. Dolfield Road, Owings Mills, MD 21117, or circle number 108 on the reader service card.

DISPLAY YOUR STUFF

With the AEA MBA-RO Reader

Automatic display of transmitted and received Morse and RTTY coded signals has come of age. It is proving to be most worthwhile for improving one's own transmitted "fist" and for allowing SWL's or visitors the opportunity to experience the thrill of Amateur Radio coded transmission.



While no machine can yet match the ability of a skilled CW operator in copying poor fists or signals buried in the noise, the MBA-RO by AEA excels even when compared against units costing much more. The large 32 character display allows much easier reading than shorter displays, especially at higher speeds such as 60 WPM or 100 WPM RTTY. The MBA-RO also features dual filters for RTTY decoding of either 170 Hz or 425 Hz (easily changed to 850 Hz) shift transmissions.

For more details, write for our latest catalog or visit your favorite dealer.

Prices and Specifications subject to change without notice or obligation.
Software © copyright by AEA.

ADVANCED ELECTRONIC APPLICATIONS, INC.

P.O. Box C-2160,
Lynnwood, WA 98036
(206) 775-7373

Telex: 152571 AEA INTL

AEA Brings you the Breakthrough!

LISTENING POST

BY GERRY L. DEXTER

WHAT'S HAPPENING: INTERNATIONAL SHORTWAVE BROADCASTING BANDS

It's time to put the receiver on "standby" and talk about shortwave broadcast DXing for a while!

Surprise-surprise! That's what the Voice of America did to people who follow, listen to, and DX the shortwave broadcast bands. The Voice has entered into a leasing arrangement with the national radio of Brazil (Radiobras) to lease time over the Brazilian transmitters. Thus, the VOA will put a clearer signal into the southern part of South America. And no, according to people in the know, the arrangement had nothing to do with the Falklands Islands crisis and, in fact, was under negotiation long before the crisis caught the world's attention.

Currently, the VOA over Radiobras transmitters is scheduled from 1130 to 1400 Greenwich Mean Time on two frequencies—15.385 and 17.740.

QRP? No, it's not the name of a new rock group or a measurement of auto emission quality. QRP is Ham talk for "low power."

While countries and stations heard and verified are the norms when it comes to measuring success on the shortwave broadcast bands, QRP is yet another method of keeping tabs on yourself and determining how well you're doing. And while, with countries and stations heard and verified it's a case of the more the better, with QRP it's just the opposite! Specifically, it's "VAC-QRP" or low-power verified all continents.

To figure out your VAC-QRP score, you just take your lowest power verification from each continent and add up the powers. The total represents your score. For instance, if you had a 50 kw station in Europe, a 10 kw from North America, a 50 kw from Asia, 10 kw from South America, 10 kw from the Pacific (Oceania), and 50 kw from Africa, your VAC-QRP total would be 180 kilowatts.

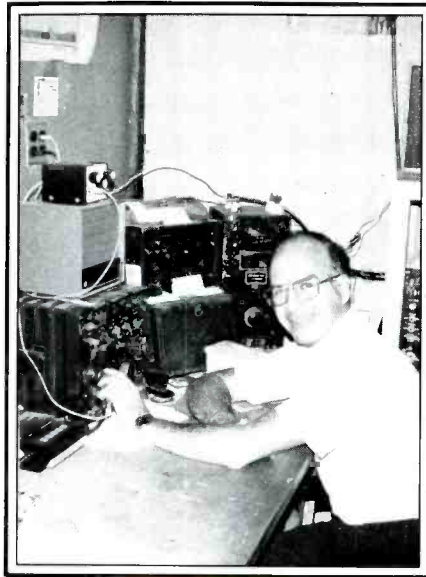

POP'COMM reporter Stewart MacKenzie, who is also head man at the American Shortwave Listener's Club. Stewart uses an R392A surplus receiver, Hallicrafters speaker, Autek QF-1 audio filter, and a BC221 frequency meter.

The idea, then, is to work towards getting that total lowered as far as possible. Just like a golf game.

One SWBC club, the North American Shortwave Association, even issues a VAC-QRP award and there are a few of its members who have certificates representing total scores of 5 kilowatts or under. This is no mean trick in this day of super high powered transmitters!

Ideally, the QSLs you count towards your VAC-QRP score should indicate the station's power on them. It might be a good

idea to keep that in mind when you send reception reports.

So, add up your score and see where you stand. Then check out our special VAC-QRP target chart for some possibilities that might help you bring those totals down!

DX Library

A publication you may find useful is Ye Editor's 1982 *Directory of Clandestine Stations and Programs*. This eight page tabulation lists currently operating clandestine stations and programs produced by revolutionary or "freedom" organizations, along with the more stable frequencies and, where known, addresses. It's available for \$3.00 (cash, check, or money order—no stamps or IRCs) from G.L. Dexter, RR4, Box 110, Lake Geneva, WI 53147.

Let's take a look at what's on the bands. **Argentina** "Liberty," the Argentine "clandestine" that really isn't much of a secret, was still being heard several weeks after the end of the Falklands War. At the time, it had moved from its earlier spot of 17.740 and was noted at 0005 GMT on 17.738, in English. (Stewart MacKenzie, CA)

Austria Austrian Radio to North America is scheduled on 5.945 and 9.770 from 0130 to 0200 GMT and 0330 to 0400 GMT and 0430 to 0500 on the additional frequency of 12.015, plus 1230 to 1300 GMT on 17.880. (K. Krist and T. Smith, via SPEEDX)

Belgium The latest schedule for Belgian Radio to North America is from 0030 to 0115 GMT on 11.695. (Glenn Hauser/SWL Digest, via SPEEDX)

Bolivia Careful DXers may expect to run across a new Bolivian station or two, or, they may find some old outlets reactivated. Stations owned by mineworker's unions in

The Listening Post's Recommended Targets For VAC-QRP

	100 kw	50 kw	10 kw	5 kw	1 kw
Europe	Radio Monte Carlo, Monaco	Radio Denmark	Icelandic State Bcstng Service, 12.175	Caltanisetta Sicily (Italy) 7.175	Aldrans, Austria 6.000
Africa	Radio Botswana, 4845	Radio Espana Exterior via Canary Islands 11.815, 15.365	Radio Nacional Angola 7.215	Radio Buea Cameroon 3.970	(none available)
Asia	Jordon, 9530, 9.560, 11.920, 7.155	Burma, 5.040	Voice of Asia, Taiwan 5.980	Radio Republik Indonesia, Kendari, 4.000	Radio Republik Indonesia, Manado 7.296
Oceania	KTWR, Guam	VLW15, Waneroo, Australia 15.425	VLR6 Brisbane, Australia 6.150	Radio Tahiti 6.135	Radio Kiribati 16.433 (SSB)
N. America	Radio Havana Cuba (50 or 100 kw)	WINB, Red Lion, PA	Radio Nacional, El Salvador 9.553	TIFC, Costa Rica, 5.055	Radio Lux, Honduras 4.890
S. America	Radio Nacional Chile, 15.150	R.A.E. Argentina, 11.710	Radio Super de Cali, Colombia 6.120	Radio America, Lima, Peru 9.510	Sucua Federacion Sucua, Ecuador 4.960

Note: in cases where one frequency is listed here and the station operate on a number of channels, the listed frequency is at the power indicated. Frequencies and powers based on listings in 1982 World Radio TV Handbook.

Bolivia have been told by the government that they may resume broadcasting. The stations were closed down after a coup over two years ago.

Brazil The government station, Radio-bras, has English programs for its North American audience from 0200 GMT on 15.290 and 17.830 (Joe Sonner, via ASWLC). Other private Brazilian broadcasters on the higher frequencies you can try for include: Radio Clube Ribeirao Preto in Ribeirao Preto on 15.415; Radio Timbira, Sao Luiz on 15.215; Radio Bandeirantes in Sao Paulo on 11.925; Radio Clube Pernambuco, Recife on 11.865; Radio Globo, Rio de Janeiro on 11.805; and Radio Marumby, Florinapolis on 9.675.

Burundi Here's a toughie! La Voix du Revolution from Bujumbura was noted on 3.300 from 0257 GMT sign on with an interval signal followed by anthem, station identification (probably in French), and then folk music. (Chris Lobdell via *Listener's Notebook* in *Frendx/NASWA*)

China Part the bamboo curtain and tune in Radio Peking's programs in English to North America from 0000 to 0200 GMT on 17.855, 17.860, and from 0200 to 0300 GMT on 17.860 and also from 1200 to 1300 on 15.520. (Thomas Knauer, West Germany, via *SCDX*)

Clandestine Radio Vatan, one of several anti-Iranian government stations, was tentatively logged at 0305 in Arabic on 15.555. (Stewart MacKenzie, CA)

Cuba Radio Havana Cuba beams to the Americas from 0100 to 0450 on 11.930, 0100 to 0600 on 11.725, 0330 to 0600 on 11.760, 0630 to 0900 on 9.525, 2050 to 2140 on 11.725 and 17.750. (*SPEEDX*)

East Germany Radio Berlin International broadcasts in English to North America from 0000 to 0045 GMT and 0130 to 0215 on 9.730 and 11.975; 0230 to 0315 on 11.840, 11.890, and 11.975; 0530 to 0615 on 6.080 and 11.890, and 2315 to 0000 on 9.730 and 11.975. (K. Krist via *SPEEDX*)

Gabon The powerful Africa Number One station is currently scheduled from 0500 to 0800 GMT and 1700 to 2300 on 4.812; 0800 to 1700 on 7.200; 0500 to 0600 and 1700 to 2300 on 11.940; and 0600 to 1700 on 15.205. (Gregorio La Rosa, Italy, via *SCDX*)

Greece You'll find both English and Greek used by Athens Radio (Elliniki Radio-phonía Tileorassís, to be precise) when they're transmitting to the Americas from 0000 to 0150 GMT on 9.685, 15.595, and 12.045; 0200 to 0350 on 9.685, 12.045, and 15.595; 1200 to 1250 on 12.045, 15.595, and 17.555; and 1500 to 1550 on 12.045, 15.595, and 17.555. (C. Olson, via *SPEEDX*)

Indonesia Radio Republik Indonesia's overseas service was heard on 15.150 and parallel 11.790 at 1625 in Arabic at good level in California. (Stewart MacKenzie)

Israel Always a good one to keep an ear on, Kol Ysrael can fill you in on the Mideast action if you follow their North American service from 0500 to 0515 on 21.760,



Remember the 1958 Brussels World's Fair? Belgian Radio did with this special QSL card.

21.710, 15.585, 15.105, and 11.640 (with 17.8115, 17.685, and 15.485 serving as alternate frequencies). Also, follow it from 1200 to 1230 GMT on 21.760, 21.625, 17.630, 15.605, 15.405, (alternates 25.640, 17.685, 15.485), and 2000 to 2030 on 21.495, 17.685, 17.630, 15.585, 15.425, and 9.009 (with alternates 17.815 and 15.485). In addition, it can be found from 2230 to 2300 on 21.495, 17.630, 15.585, 15.425, and 11.640 (alternates 17.815, 17.685, and 15.485), and again from 0000 til 0030, 0100 to 0125, and 0200 to 0225 on 15.585, 11.640, and 9.815. (Harold Frodge and Stewart MacKenzie, via *SPEEDX*)

Italy RAI in Rome is scheduled to North America from 0100 to 0120 GMT on 9.575 and 11.800. (M. Chinsky and R. Reinecker, via *SPEEDX*)

Mexico Look for Radio Mexico from 2000 to 2200 GMT on 15.430, 2200 to 0500 on 5.985, 9.705, 11.770, 15.430, and 17.765. (Rolf Lovstrom, Norway in *Listener's Notebook*, *Frendx/NASWA*)

Netherlands Radio Netherlands entertains and informs its North American audience currently from 0230 to 0325 on 6.165 and 9.590 and again from 0530 to 0625 on 6.165 and 9.715. All North American service transmissions listed here are via the Bonaire, Netherlands Antilles, Relay Station. (Pat Rady via *SPEEDX*)

New Zealand Hopefully, Radio New Zealand will still be on the air when you read this. It's scheduled to Australia and the Pacific from 0825 to 1215 on 11.960, 15.485; 1800 to 2105 on those same frequencies; and 2115 to 0815 on 17.705 and 15.485. (R. Drollinger and C. Olson, via *SPEEDX*)

Papua/New Guinea Port Moresby was noted on 3.925 at 0810 GMT in English with a religious program. (Stewart MacKenzie, CA) The outlet on 4.890 is a regular for

most of the year in most parts of the country during the early morning hours. (ye editor)

Portugal Radio Portugal has English to North America from 0300 to 0330 on 6.155 and 11.925; 0530 to 0600 GMT on 6.155 and 9.575. (Norm Grosvenor, via *ASWLC*)

Qatar This Arabian gulf country has a new 250 kw transmitter which should improve its reception. Try 15.505 from 0245 to 2100. Programs will be mostly in Arabic. (UADX via *SCDX*)

Singapore Singapore Broadcasting Corporation has been logged on 5.020 around 0845 with a popular music program in English. It can also be found on 9.740 at 1705 with news in English and on 11.940 with their "Radio One" service at 1530 in English with mood music followed by news at 1600. (Stewart MacKenzie, CA)

Syria Radio Damascus should reactivate their foreign service if they haven't done so already. They'll be using 2 to 250 kw transmitters, but we're still waiting for frequency information. If you spot them, let us know when and where. (*SCDX*)

Uganda Radio Uganda has resumed a schedule to North America and is currently on from 0200 to 0400 GMT on 15.325. Transmissions may still be sporadic, however. (B. Annis, via *SPEEDX*)

Ukraine Radio Kiev is scheduled for North America from 0200 to 0230 GMT on 9.800, 11.735, 11.770, 15.180, and 15.405 and 2330 to 0000 on 9.800, 11.735, 12.020, 15.180, and 15.405. Many of the transmitters used (if not all) are actually located somewhere else in the Soviet Union. (R. Fraser and J. Marin, via *SPEEDX*)

United Arab Emirates Try for Radio and Color TV Dubai, one of the UAE member states, from 0330 to 0400 to North America on 15.320 and 17.775. (B. Annis and R. Reinecker, via *SPEEDX*)

United States A broadcast band station, WQBA in Miami which transmits in Spanish

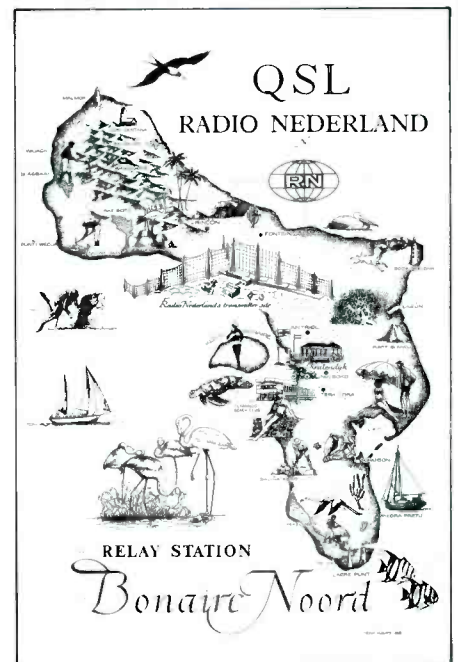

PRODUCTS

REVIEW OF NEW AND INTERESTING PRODUCTS

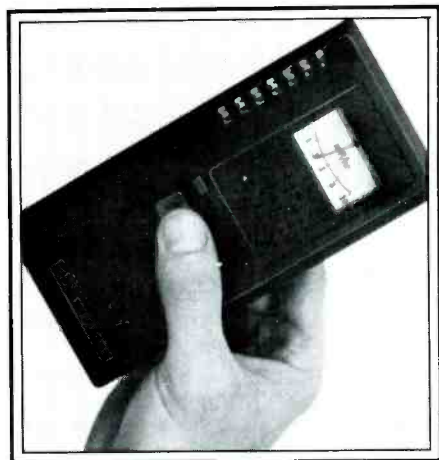

New Geiger Counter

RDX nuclear, a Los Angeles based firm, is pleased to announce the introduction of the model DX-1 geiger counter. Lightweight and battery powered, it is priced to be attractive to anyone. Advanced circuitry allows several meter scales to be compressed into one and a new overscale has been developed that causes beeping at high radiation levels. The DX-1 design was directed toward individuals with interests in mineralogy, ecology, and survivalism as well as industry and medicine. It sells for the introductory price of \$69. For more information, contact RDX nuclear, 2003 Canyon Drive, Los Angeles, CA 90068, or circle number 106 on the reader service card.

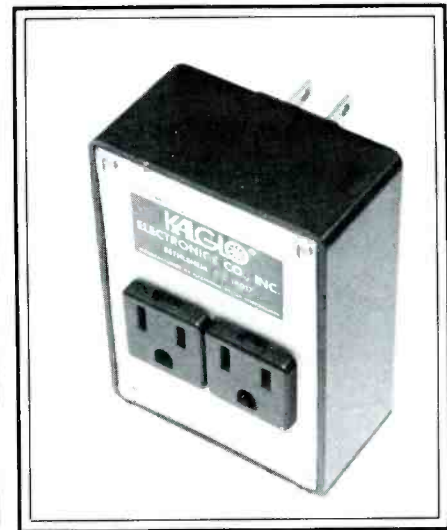

Surge Suppressors With Noise Filter

Kalglo Electronics Co., Inc. has developed a product especially designed to protect sensitive and expensive electronic equipment from damaging power line trans-

ients, high voltage surges, and conducted electrical noise interference.

Designated the "SPIKE-SPIKER" (T/M) they are designed to clip transients and provide RF "HASH" filtering between the electronic equipment and motorized equipment or other "noisy" devices in the vicinity to help prevent interference.

The SPIKE-SPIKERS are available in 3 models: the Deluxe Power Console which comes equipped with (8) individually switched 120 VAC outlets divided in rows of separately filtered circuits, a main on/off switch, fuse and indicator light; the Quad-I and Quad-II units, which are 4 socket plug-in wall mounted devices; and the MINI-I and MINI-II units, which are 2 socket plug-in wall mounted units.

All units are prewired and ready to use. Stop unexplained equipment malfunctions and eliminate static and interference from the power line. For more information write: Kalglo Electronics Co., Inc., Department: PC, 6584 Ruch Rd., East Allen Twp., Bethlehem, PA 18017, or circle 107 on the reader service card.

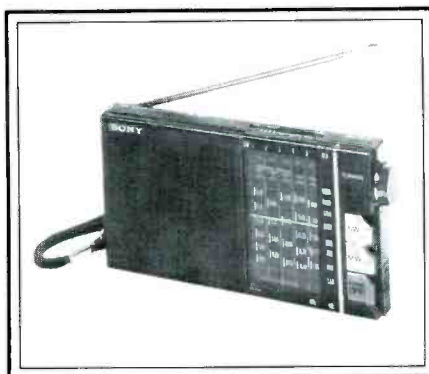

Pocket-size World Band™ Radio

The new ICR-4800 pocket World Band Radio from Sony is a palm-sized, six-band unit weighing only 8 ounces with batteries, that offers five shortwave bands plus AM reception. Measuring 5 1/4 inches wide by 2 1/8 inches high by 7/8 inches deep, the ICR-4800 is small enough to fit in a shirt pocket. The suggested retail price is \$89.95. For more information, circle number 103 on the reader service card.

Brainy Accessory

The Phone Controller™ is a multi-featured system that combines numerous functions in a single package. Designed for use either with the Touch-Tone™ or rotary-dial telephone circuits, the unit stores up to 30 different 16 digit numbers (expandible). Its memory is quickly and easily programmed

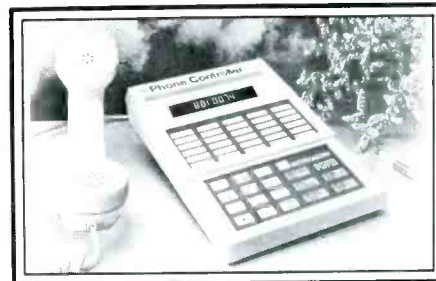

using English language logic that is unique in the industry. A built-in speaker provides on-hook dialing and the unit starts operating with the touch of a single memory recall button. The speaker may be turned back on for group listening.

The keyboard itself is unusual, and uses a solid-touch-sensitive surface imprinted with the keyboard positions. The memory touch buttons are overlaid with a printed sheet of paper that outlines the buttons and can be typed or written on to indicate names in storage. A supply of the replaceable memory storage cover sheets is provided with each machine and replacements are available.

The Phone Controller™ has such built-in functions as automatic redial of the last number, and a programmable redial of up to 14 tries (at one minute intervals) until the called party answers. On all such tries, the unit will disconnect after six rings of an unanswered phone, with manual override. Pauses can be programmed into any number position for use with Centrex, access codes, company networks, and non-telephone company toll systems. A hold control with display is also featured.

Any numbers entered or being dialed are displayed on the industry's largest LED readout, which also acts as the display for a quartz crystal-controlled digital clock that is on when the unit is not being used for dialing. The clock also becomes a fully automatic elapsed-time indicator whenever the phone is being used. Calls may be dialed manually from the tone-type dialing pad on the Phone Controller, saving the time that is ordinarily wasted with a rotary dial. The dial output is switch-selectable: tone-type, fast or slow outpulse.

The brainy unit "talks back," providing the user with a cheerful beep tone each time a key is depressed. This feature assures the user that each entry stroke has been registered, in addition to the LED display of the entry. The Phone Controller™ produces longer beeps when locked and an unauthorized person tries to use it. This is made possible by its unique hidden floating combination lock, a number key combination that changes constantly. One additional security feature: the paper cover sheet with names

typed on it can be instantly removed for lock-and-key storage.

The Phone Controller™ uses a backup battery to retain the memory and clock functions and to provide full operation in the event of a power failure. It also permits the unit to be moved from room to room with no loss of memory. Battery type is a standard 9-volt transistor radio battery which is not supplied with the unit.

The instrument is compatible with all of today's telephone systems. While it is designed for use with modular-type telephones, it can be used with virtually any kind of installation, including key-type office phones, wall phones, and standard, single-line, non-modular types. The unit can be used on a desk or can be wall-mounted, and low-cost accessory installation kits convert non-modular telephones.

The Phone Controller™ is manufactured in the U.S.A. to meet rigorous technical specifications. The low selling price is due to the company's high level of manufacturing automation. Manufacturer's suggested retail price for the Phone Controller™ Model PC-30 is \$129.95 in the United States. For more information, contact: Dictograph U.S.A., 89 Glen Cameron Road, Thornhill, Ontario, L3T 1N8 Canada, or circle number 102 on the reader service card.

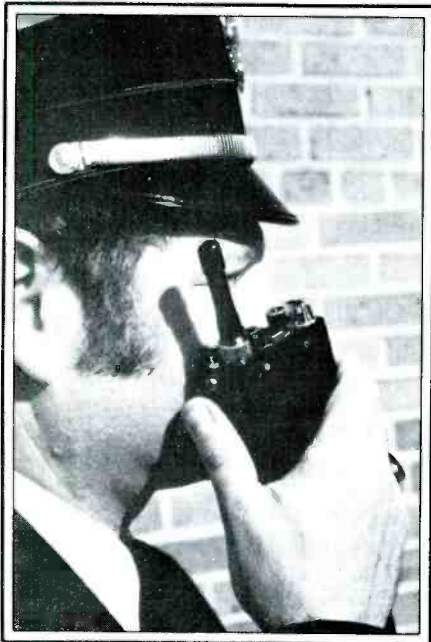

Rugged, "Stubby" Antennas For UHF Portables

Two 406-512 MHz "Stubby" portable radio antennas recently developed by The Antenna Specialists Co. are designed to withstand the rough handling typical of portable operations that often quickly destroy telescopic. Model PD22 fits General Electric PE Series UHF portables; Model PD30 fits most Motorola, REPCO, and other UHF portables. They are suited for airport systems, building security systems, and urban systems employing a comprehensive receiver voting configuration where maximum radiation efficiency is not required.

Jacketed with a high temperature PVC coating, both models are completely insulated and cannot be shorted out. Length is approximately 2½ inches. Nominal impedance is approximately 50 ohms, depending on the ground plane of the portable.

In all, A/S offers more than 100 flexible antennas for portable applications, at every frequency range. The firm developed the first flexible antenna in the mid-sixties.

For detailed product information, write to: Marketing Department, The Antenna Specialists Co., 12435 Euclid Avenue, Cleveland, OH 44106, or circle number 101 on the reader service card.



Electra To Manufacture For AT&T

Electra Company announced that it will manufacture cordless telephones for American Telephone and Telegraph (AT&T). Initial production and deliveries have begun.

Marketed under the name NOMAD™ 1000, a trademark of AT&T, the phone was designed by Electra and will be manufactured at Electra's Cumberland, Indiana, facility. The NOMAD 1000 makes use of Electra's exclusive circuitry that operates full duplex entirely in the 49 MHz range. The NOMAD 1000 and Electra's Freedom Phone® 4000 are the only cordless telephones available that use this sophisticated circuitry. This frees the system from most common electrical interference and provides increased voice clarity.

In addition, custom microprocessor and specially formulated software make it possible for the user to choose between rotary pulse or pure tone activated dialing so that the phone is capable of full central telephone equipment interface. It also makes possible automatic dialing capability, which allows the user to store up to three numbers in memory and dial any of them by pushing a button, plus a programmable security system to prevent unauthorized usage of the system.

Other features in the new NOMAD 1000 cordless phone include a redial button for one button redialing of the last number called, a battery low light, a charge light on the base, volume control on the handset, power light, and double modular external jacks on the control unit (for regular phone line hook-up and for any telephone accessories such as phone answering machines, etc.). For more information, circle number 104 on the reader service card.

On-Glass Mobile Antennas

The Antenna Specialists Co. is now offering a complete line of professional Avanti on-glass, ½-wave antennas with models covering low band, high band, and UHF. The antennas feature a "DUO-BOND" adhesive system that reliably and instantly attaches the antenna's base and coupling units to glass, fiberglass, or other non-conductive surfaces. Extensively field tested in a variety of temperature and humidity extremes, the DUO-BOND system combines a new double-sided foam tape adhesive, specially formulated for outdoor windshield applications, with a fast-curing silicone adhesive surround sealant for quick drive-away and a firm, resilient bond.

A/S Avanti on-glass antennas can be completely installed on virtually any vehicle in about 15 minutes. There are no holes to drill and no special tools needed. Because the antenna can be easily mounted near roof level and does not require a ground plane, its performance often equals or exceeds conventional 5/8-wave antenna installations. Pattern distortions are minimized. The capacitive impedance matching circuitry, inherently a low noise design, operates efficiently with the window glass or any non-conductive material up to ¾" thick. The ½-wave antenna is also exceptionally broad banded, eliminating critical adjustments to achieve maximum scanner or transceiver performance.

For more information, contact Marketing Department, The Antenna Specialists Co., 12435 Euclid Avenue, Cleveland, OH 44106, or circle number 113 on the reader service card.

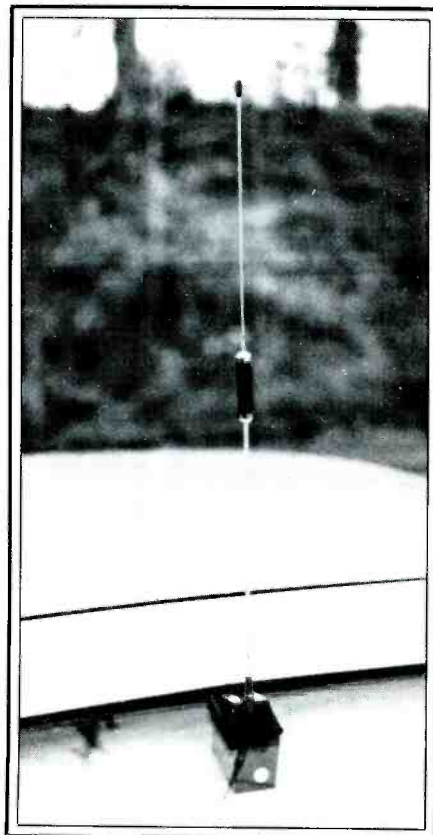

INSIDE THE WORLD OF TVRO EARTH STATIONS

Westar IV & V Expand Cable TV Horizons

The Satellite TV world has been drastically altered by the addition of two 24 transponder satellites within the space of just four months. Westar IV & V have replaced two aging satellites at the end of their predicted operational life and these new birds promise to deliver some of the very latest in cable television programming. Some of the new services that will appear on these satellites could rapidly change the way American business and the American consumer get their news information. And it looks as if Westar V will be primarily dedicated to cable television service as is Satcom IIIIR and should offer stiff competition to Satcom's established cable network fare.

Western Union, the oldest communications corporation in the United States, was also the first to use satellite communications for the domestic relay of telephone and television signals from one area of the country to another. In 1974, Western Union began their satellite service with the successful deployment of Westar I. Westar I provided a total of 12 transponders or channels each with the capability of handling 1 color television signal or 750 simultaneous telephone conversations. Westar I was followed by two sister satellites, Westar II & III. This first generation of Western Union satellites has given excellent service over the last eight years. But since these satellites were nearing the end of their life, it was necessary to replace them with newer ones that could take advantage of recent satellite design improvements and offer enhanced performance over the next decade.

This year we have seen the emergence of the second generation of Western Union satellites. Westar IV was launched in early 1982 from Cape Canaveral, Florida, on top of a Delta rocket and became operational on April 5th, after replacing Westar I at 99 degrees West. An identical second satellite, WESTAR V, was launched June 8th, and became operational on July 20th, replacing Westar II at 123 degrees West. Westar I & II have been co-located at 79 degrees West and will serve as back-up satellites.

These second generation Westar birds have several improvements which increase their performance capabilities over the satellites they have replaced. Their larger size (22.1 feet high, 7.2 feet wide) and weight (1,290 pounds) accommodates the additional solar cells, batteries, and electronics required to expand from 12 to 24 transponders. Each transponder can handle 1 color television signal or up to 1200 two-way telephone conversations. Westar IV & V are capable of generating over 800 watts

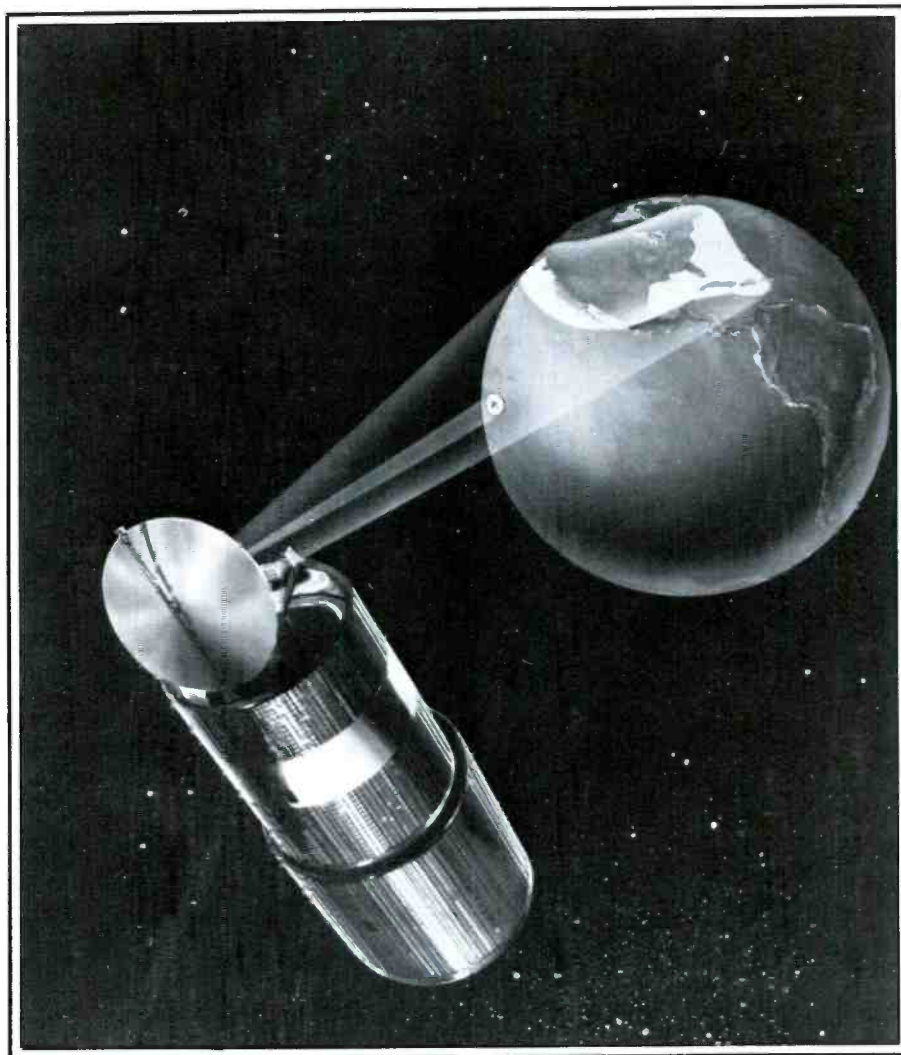

Western Union's Westar IV & V. Courtesy of Western Union

of power. Each transponder transmits 7.5 watts of power instead of the 5 watts used by transponders on Westar I, II, & III.

This higher power output allows parabolic antennas as small as eight feet in diameter for private TVRO reception throughout most of the continental U.S. (CONUS). Also, the antenna pattern or footprint generated by Westar IV & V provides coverage into Alaska, Puerto Rico, and the Virgin Islands. Additional spot beam coverage of Hawaii allows reception there on 12 of the available 24 transponders.

The main antenna on Westar IV (or V) can be folded over during launch and the cylindrical body telescoped down to a shorter dimension. Like most other satellites, Westar IV was initially placed into a highly elliptical orbit (called the transfer orbit) where the bird is made to spin about its axis. Upon

reaching that point of the orbit furthest from earth (called the apogee), the satellite's rocketry fires, placing the bird into a circular geosynchronous orbit above the equator. Once in position, the antenna is unfolded and the cylindrical solar array extended to its maximum size. A series of telemetric commands from Western Union's New Jersey earth station causes the satellite to despun and orient its antenna system earthward.

Initially, the satellite is located at one extreme end of the satellite belt above North America that stretches from 80 to 135 degrees West. Here the bird is tested before being maneuvered into its final orbital slot. After deployment, Western Union must continually track the satellite and make periodic adjustments via telemetry so that the bird maintains a constant position relative to the earth. Western Union engineers also moni-

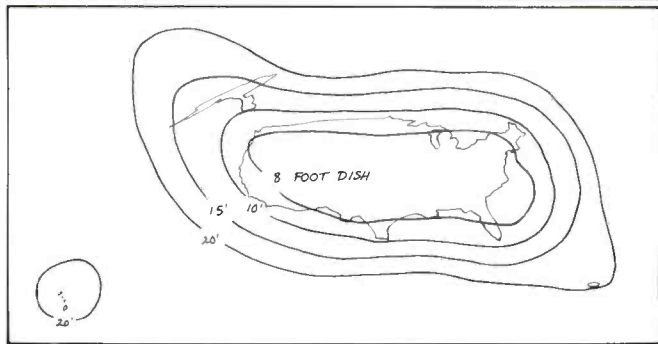

Footprint for Westar IV at 99° West.

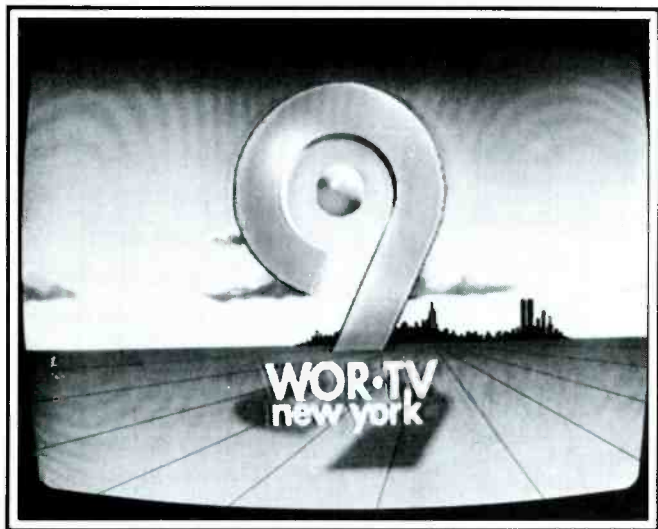

WOR-TV N.Y.C. Channel 9 from Westar V July 20th, 1982. Photo by Michael Bonnicksen

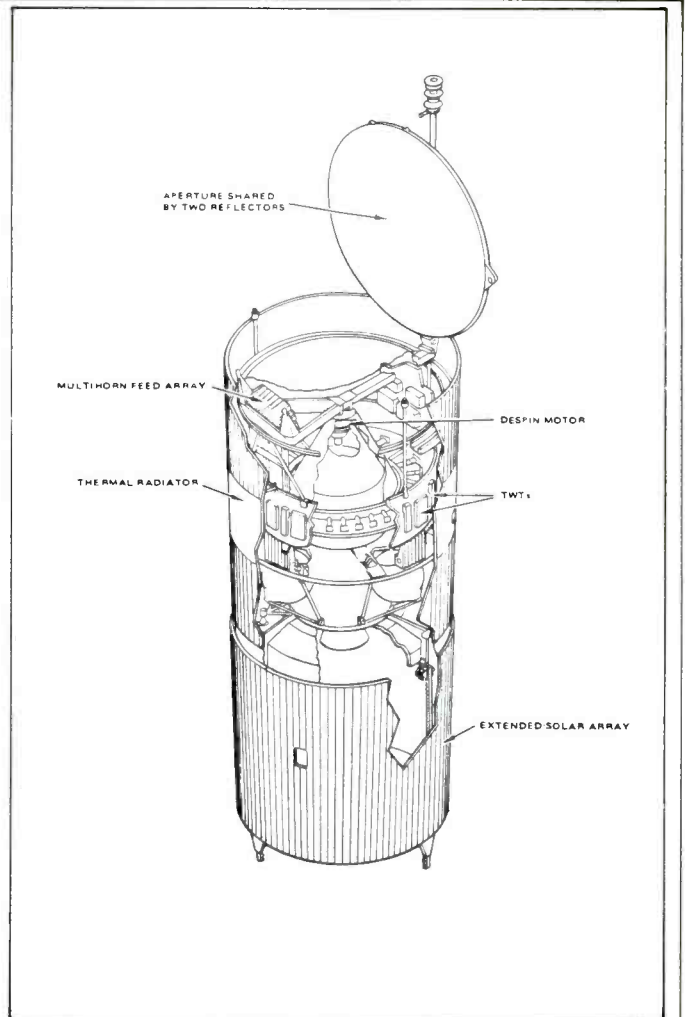

Inside view of Westar IV (V). Courtesy Hughes Aircraft Co. Space & Communications Group.

for the quality of performance of each of the 24 transponders on board. In event of a failure in any portion of the satellite, the command center can assist Westar IV or V's on-board computers in pinpointing the faulty module and switching in backup spare modules. This is an essential feature since there is no possibility of in-orbit repair after a satellite has been deployed.

Westar IV and V are the first 24 transponder satellites ever to use the gyroscopic spin technique to maintain stability and pointing accuracy of the onboard antennas. Once in orbit, the main body revolves at a speed of approximately 50 revolutions per minute, while the communications equipment platform that supports the antennas and 24 transponders is despun to remain accurately pointed earthward at all times. The satellite's use of 24 transponders is made possible by vertically polarizing one set of 12 transponders and horizontally polarizing the other set. This is accomplished by constructing the satellite's main antenna out of two superimposed wire grid reflectors, one for each polarity. These reflectors are slightly offset from each other, which allows separate feedpoints to be used for two transponder sets, while allowing for maximum compactability in satellite construction.

Since becoming operational in April of this year, Westar IV has been the home of several cable network services. Western Union had announced that this was only a temporary arrangement and that many of these cable services would be transferred to Westar V once it had been successfully launched and tested. Since Westar V's appearance on July 20th, I have observed several cable networks being transmitted simultaneously by Westar IV & V. Cable companies were notified of the eventual shift and given until July 26th to reorient their earth station antennas onto the new bird. By early August, simultaneous transmission had ceased and Westar V was fully operational. By combining preliminary reports issued by Western Union with direct observations of Westar V during its first few days of operation, I can provide a tentative transponder by transponder guide to what the latest Westar satellite is transmitting now and what it will be providing in the near future:

Westar V Transponder Listing

- 3 (H) WOR Superstation N.Y. Channel 9
- 4,6 (V) Dow Jones News/Retrieval service
- 7 (H)
- 8 (V) Satellite News Channel (SNC) Region A

- 11 (H) Satellite News Channel National
 - 14 (V) SNC Region B
 - 15 (H) SNC II starting April 1983
 - 16 (V) SNC Region C
 - 17 (H) Nashville Network
 - 18 (V) SNC Incoming News Feeds
 - 20 (V) UTV Involvision
 - 21 (H) Disney Network (East Coast Edition)
 - 23 (H) Disney Network (West Coast Edition)
 - 24 (V) Black Entertainment Television
- (H) Horizontally polarized
(V) Vertically polarized

Westar V's Cable Network Programs

Satellite News Channel: SNC is a joint venture of ABC and Westinghouse and could provide stiff competition to Turner Broadcasting Co.'s *Cable News Network*—which already has a cable viewing audience of over 10,000,000 and is carried by over 3,000 cable companies. CNN will also be going international via a Pacific INTELSAT satellite in 1983, carrying CNN News to Australia and Japan. ABC/Westinghouse is trying to overcome CNN's advantage by offering cable companies up to \$1.50 per subscriber to switch to their service. SNC will also require no monthly fees from local cable companies to use their programming. Ted



Satellite News Channel from Westar V July 20th, 1982. Photo by Michael Bonnicksen

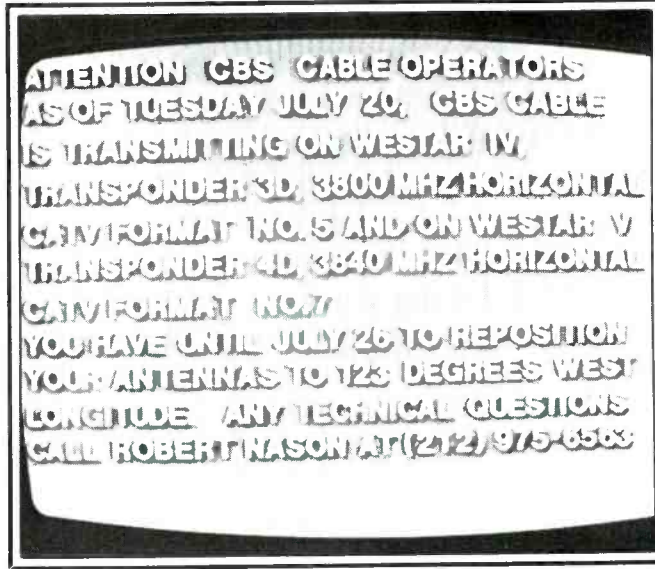

CBS Cable operator information from Westar V July 20th, 1982. CBS has cancelled CBS Cable. Photo by Michael Bonnicksen

Turner is combating this marketing onslaught by reminding cable companies that Turner Broadcasting supported cable television from the beginning, when broadcasting networks like ABC were actively trying to curtail its spread. Just how long that argument will be effective in the face of large cash offers by ABC/Westinghouse to cable companies remains to be seen.

SNC began operation on June 21st on Westar IV, but has since changed over to Westar V. By utilizing 24 affiliate stations across the United States, SNC can provide up-to-the-minute regional news. SNC is using a total of 5 transponders on Westar V. Transponder 11 is the main channel, supplying all the International and National news stories. Three other transponders are used to provide regional news coverage which can be inserted by local cable companies onto the SNC channel for 5 minutes out of every hour. The fifth SNC channel is being used for feeding live news stories back into the main SNC station. There are plans for a second SNC channel to be added in 1983 which will provide more variety and in-depth news coverage. This will differ from the initial program which boasts "Give us 18 minutes, and we'll give you the world!"

Nashville Network: This new network originates from Opryland in Nashville, Tennessee and will offer 24 hours a day of down-home entertainment, Nashville style. Much of the programming will be centered around Nashville's music industry, with shows like *Stars of the Grand Ole Opry*, *Off the Record Rack*, or *Nashville After Hours*. Other country/western entertainment will also be featured, including game shows, live variety, and sports. One regular weekday situation-comedy called *I-40 Paradise* will take a look at life centered around a roadside diner. Other programs will examine Nashville's musical past in *Yesteryear in Nashville* or current local events in *Nashville Now* hosted by Ralph Emery. This is expected to be operational by March, 1983.

The Disney Channel: Starting in January, 1983, Walt Disney Productions will offer 16 hours a day of family entertainment drawn from their extensive files of Disney movies, cartoons, and television programs. There will also be new features created especially for the new cable service. The Experimental Prototype Community of Tomorrow (EPCOT) currently under construction at Walt Disney World in Florida will provide special productions opening "new frontiers in entertainment, education, imagination, and discovery" for cable TV viewers nationwide. This city of tomorrow will be explored in several segments called "FutureWorld Specials." With two transponders available on Westar V, The Disney Channel is expected to offer an East Coast and a West Coast edition with a three hour time difference between the two.

Involvision is a 24 hour a day advertiser-supported channel that gives cable viewers the opportunity to be part of the program in a number of different ways. Toll free numbers will be provided so that viewers can call in opinions or questions for special guests or to register their preference in public opinion polls concerning specific issues. There will be a variety of consumer oriented programs that inform viewers about new products and services as well as educational features that encourage the viewer to participate at home. Start-up time for this service will be early 1983.

Black Entertainment Network: Offering quality films, music performances, and theater featuring black entertainers. Also programming for women covering public affairs, cooking, health, and sports. Seven days a week, 8 PM to 2 AM.

Dow Jones News/Retrieval Service: Dow Jones, the producer of the *Wall Street Journal*, the *AP/Dow Jones International Business and Economic Newswire*, *Barrons National Business and Financial Weekly*, and the *Far Eastern Economic Review* will begin late this year to offer a two-way

news/retrieval service on Westar V that will be available to cable companies throughout the United States. This news service will feature a scrolling text format running in 15 minute cycles with each cycle having up to 35 separate stories taken from their many publications. This service will be available 24 hours, 7 days a week. Dow Jones will supply each cable company with a decoder which will allow cable subscribers to view the news information. Additionally, individual subscribers that are equipped with their own computer facilities will be able to interact with the Dow Jones main computer via a telephone to satellite circuit.

Reconfiguration of Westar IV

Several cable networks on Westar IV have elected to remain operating on that bird for the foreseeable future:

- 16 (V) Spanish Independent Network
- 18 (V) Financial News Network
- 19 (H) Eros
- 22 (V) Satellite Program Network
- 24 (V) Galavision

15, 17, 21, & 23 (H) Public Broadcasting System (PBS)

Westar IV will also continue to provide the Public Broadcasting System (PBS) with affiliate feeds to over 280 PBS stations around the U.S. via 160 earth stations. Popular programs like *Sesame Street*, *The MacNeil Report*, *Masterpiece Theater* and the *ABC Captioned News* are all transferred to affiliates by Westar IV. Several other transponders on this satellite will be allocated for use by "occasional video" customers. Transponder time is sold to independent syndicators and distributors or to individual companies for teleconferencing. Westar transponders are also being used for news feeds for various broadcast and cable networks. Currently, one Westar transponder is being used by ABC News to feed Max Robinson's live segment for the *ABC World News Tonight* from Chicago back to Washington D.C.

MONITORING THE 30 TO 512 MHz "ACTION" BANDS

Winter Monitoring

Now that winter is upon us, it's a perfect time to take a look at the most interesting frequencies to listen to in this finest of all monitoring seasons. It must be remembered that wintry weather can affect just about the whole of the United States, and even though Little Rock will not receive the fifteen inches during a particular storm that Milwaukee may pick up, Arkansas as a whole will frequently be paralyzed by a coating of thick and stubborn ice.

I'm sure many of you have heard stories of how Washington, DC is forced to shut down from three inches of snow; and the further south you go, the less snow it will take to inflict the same havoc. Monitoring potential across latitudinal lines is hence all relative, for although you may need a blizzard to set the Minnesota Defense Civil Preparedness Agency into action, it will only take that layer of ice or small accumulation of snow in most other states to set into motion what I believe to be the most fascinating of all radio communications.

When a snow or ice storm hits, it is always best to have a frequency list put aside that you have specially prepared for just this wintry occasion. I look forward to monitoring during the heavy weather so much that I start writing up my "programs" in August.

If you're wondering just where to begin your winter program, you'll be glad to know that that's the easiest of all parts. The police are far more interesting in snow than fire departments are (although I know you fire buffs out there might disagree) and thus I

suggest that you begin your lists with local, county, and state police agencies.

How many channels of these departments should you put in? Well, this of course depends somewhat on your own preferences, but mainly is a factor of the number of channels that you have available. Basically, if you've got a number of scanners, then put down just about all the police agencies that you're able to receive. If you don't have a lot of units, then go with your local and some favorite surrounding communities' police frequencies, along with all the state and county channels possible.

Of course, many of you will only have a county and/or state force covering your area, but that will just free you up for what comes later. Those of you living in the very major cities will probably stick with listening to just the city channels, pointing out that local variances will always come into play.

Continuing on, finish up the police section of your program with all of the intercity frequencies you can gather. You can learn so much about what's going on in areas that you can't or don't cover that the importance of the intercity or intersystem frequencies can really not be expressed enough. Next, you should have your favorite fire frequencies. However, you fire nuts should really leave out some of those borderline receivable channels and save space for other things. Following that should be intercity fire frequencies (many have intercity and local on one frequency), which is always a must.

A few of the most active ambulance fre-

quencies such as 155.34, 155.28, and the locally active Med 1-10 channels (462.950, 462.975, 463.000-463.15—base, and 468.000-468.15—mobile) require little space but can provide some of the most interesting and heart-stopping listening. In a similar vein, the Red Cross (nationally on 47.42 with backups on 47.58 and 47.66 MHz and with local channels scattered about on the 151-152 MHz and 461-465 MHz business ranges) provides food, shelter, and comfort to storm victims and support services to all other public safety agencies.

Leaving the more obvious of items, we enter into the more obscure; but it is these offbeat agencies that really make winter monitoring so enjoyable. We begin with the state and local highway department (or Department of Transportation) frequencies. These are an absolute must! Not only are these frequencies informative as to weather (which is usually broadcast regularly over state channels) and road conditions, but they can also be just plain fun as the plow and sander drivers pass the time away by having a blast over the airways.

State highway departments are normally tied in with state and federal civil defense agencies, thus providing the next step in your winter program. Civil Defense networks vary from state to state (both in frequency and district format and in the usage and working condition of the communications equipment). Some states use a totally countywide system, while others will have a state network, and still others will have both.



Wintertime fender-benders activate police and EMS frequencies.
Photo by N.E. News & Photo Co.

Think of how many different frequencies will come into use in the aftermath of this mess. Photo by N.E. News & Photo Co.



Weather emergencies always mean increased activity on the fascinating highway maintenance frequencies. Photo by N. E. News & Photo Co.

All frequencies are licensed under the local government band. Also, try to find out if your community has its own C.D. or C.P. (civil preparedness) radio.

Going hand-in-hand with these C.D. nets is the usually unknown but very important Federal Emergency Management Agency

around the nation. A common frequency for this system is 169.875 MHz. Although I don't know an awful lot about the government people who run the FEMA, I do know that much of their main operations are coordinated with Army and Air National Guard crews.

Also tied in with these civil defense agencies are Amateur Radio operators, Hams who operate very interesting and informative nets on just about all of their different bands, including shortwave. Generally, the most active Ham channels will be receivable by most scanners, such as their 144-148 MHz "2 meter band." However, many Amateur civil defense nets operate between 50.00-54.00 and 220.00-225.00 MHz, either so that we scanner people can't listen in or because other bands are just a little too congested.

Also available for Hams is the 440-450 MHz range, which is usually receivable on a police radio. I strongly urge you to search around all the aforementioned ranges and to inquire at Ham clubs and even national guard armories for their active channels. When a storm truly hits hard, listening in on these frequencies could even go as far as helping to save your life.

Other frequencies that you might consider having in your program, or relying on as alternate frequencies for the scanner, are the local utility people (for hearing about downed trees and wires) and towing firms

who must work together constantly with the police. The Army Corps of Engineers, which is prominent nationwide on frequencies in the 163 and 167 MHz areas, is vital in the preservation of dams, canals, and bridges which become threatened by heavy precipitation of any type.

REACT teams, generally located in the General Mobile Radio Service range of 462.525 through 462.725 MHz, are usually quite active helping motorists, as are the traffic-copter and traffic-car teams in the air and on the road. Naturally tied with traffic reporting crews are the all-important remote broadcast (television and radio) and press companies. These agencies are always fascinating to listen to — especially when you can hear the director speaking, or better yet, yelling at an on camera reporter to end his or her story. This goes double in a storm.

All in all, you should be set with your winter program now, although you'll probably have some variations or additions that you'll want to make (such as putting in some marine frequencies, i.e. 156.800 calling and rescue and 157.100, 157.150, and 157.175 MHz, the more common Coast Guard channels if you live along an inland waterway or a coastline). I hope this system of devising your winter monitoring list works well for you. Please let me know and please write in if you have any other frequency ideas on monitoring any season or any type of event or disaster.

TERMINALL

SWL's

COPY NEWS AND WEATHER ON YOUR PERSONAL COMPUTER



TRS-80*

apple*

ATARI*

Call or write for specifications
(209) 634-8888 or 667-2888



MACROTRONICS, inc. ®

1125 N. Golden State Blvd.
Turlock, California 95380

*TRS-80 is a registered trademark of Tandy Corp.
*Apple is a registered trademark of Apple Inc.
*Atari is a registered trademark of Atari Inc.

CIRCLE 26 ON READER SERVICE CARD

LEARNING THE MORSE CODE?

Try the All New
AEA BT-1 —
Basic Trainer For
Morse Code



AEA, in conjunction with ETS (Educational Technology and Services)*, has developed the BT-1 Code Trainer. ETS methodology, based upon research by a prominent mid-west university, has demonstrated that a typical student using this system and the BT-1 can learn Morse code to speeds of 20 WPM in four weeks based upon two 20 minute daily training sessions.

The pre-programmed BT-1 computerized trainer will allow you to achieve proficiency in Morse code faster than any other known method.

No prior knowledge of Morse code is required to use the BT-1. There are no tapes to purchase or wear out. The BT-1 operates from a 12 VDC source or from the AEA 117 Vac wall adapter unit, AC-2. For portable use the BT-1P is available with Nicad batteries and comes with a charger that operates from 117 Vac. The unit can also be used in mobile settings via the 12 VDC system.

*Education Technology & Services, see page 81 October 1981 issue of Ham Radio Magazine.

Prices and Specifications
Subject To Change Without
Notice Or Obligation.

AEA
Brings you the
Breakthrough!

See the BT-1 at your dealers or write:
Advanced Electronic Applications, Inc.
P.O. Box C2160
Lynnwood, Washington 98036
(206) 775-7373 Telex: 152571 AEA INTL

CIRCLE 72 ON READER SERVICE CARD

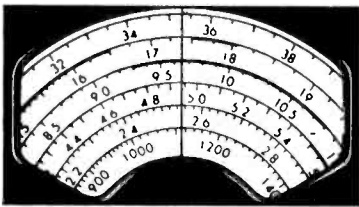

COMMUNICATIONS CONFIDENTIAL

BY HARRY L. HELMS

YOUR GUIDE TO SHORTWAVE "UTILITY" STATIONS

If you do enough listening on the short wave bands, you'll eventually run across some signals that will make you stop and wonder what on Earth you're listening to!

One persistent puzzle for the past few years has been the numerous mystery beacons. These continuously repeat one or two letters in CW with no other identification, such as "K" or "TA." Occasionally, these beacons are interrupted by signals that resemble radioteletype, but only briefly.

Direction-finding techniques indicate these beacons are located in Cuba. But what are they for? If they are for navigation, they are extremely crude and far less accurate than alternative methods (such as long-wave). If they are merely markers for the sporadic radioteletype signals, why not use ordinary VVV or CQ markers and call signs? If the purpose is secrecy, it's not working; the strange identification attracts far more attention than an ordinary marker would. Whatever they are, they aren't difficult to hear. Tune outside the broadcasting and Amateur bands at night for a couple of hours and you'll likely hear a few.

There are many other unusual signals you may eventually stumble across. Some are pulses of carrier or strings of continuous dots or dashes. Others are rapid "beeping" noises. And listeners sometimes eavesdrop on weird, repeating electronic or "flute-like" tones. The secret to hearing them is to carefully tune around the bands during the evening and night hours.

If you tune to such frequencies as 4725, 6723, 6761, 9027, 13215, and 15018 kHz, you may hear SSB stations using call signs such as "Estimate," "Bidly," "Arizona Pete," and "Morphine." Are these renegade CBers or what?

Actually, these are tactical call signs used by various U.S. military stations. Such call signs are changed frequently and with no advance warning to the casual listener. If these call signs leave you completely confused, that's the entire point. Such call signs are also supposed to confuse any "enemies" who are listening in.

A very active user of tactical call signs is the Strategic Air Command (SAC). Active SAC frequencies include 4725, 6761, 9027, 11243, and 13245 kHz and all transmissions are in SSB. In the event of a nuclear attack, SAC would be involved in retaliatory efforts. Instructions to attack would naturally be in code. You can tune in transmissions, known as Foxtrot broadcasts, believed to be updated instructions regarding



Nifty QSL from Canadian "time" station isn't hard to get if you're set up in a good reception area.

SAC's retaliatory role. These are known as Foxtrot broadcasts because each transmission begins with the word "foxtrot." The rest of the broadcast consists of an unintelligible jumble of letters and numbers. Listen for them on the hour and each 15 minutes following the hour.

Some tactical call signs on SAC frequencies do not change, however. "Sky King" is a general call sign for any ground station and "Skybird" is a general call for an airborne bomber. SAC's airborne command post is always known as "Looking Glass". Listen long enough on SAC frequencies and you'll eventually hear it.

Listening Reports

Here are this month's listening reports. All frequencies are in kiloHertz (kHz) and all times are GMT (that's EST plus five hours). We welcome your reports of what you're hearing. Send your loggings to *Popular Communications*, 76 North Broadway, Hicksville, NY 11801. Please include an SASE if you'd like a reply.

A special welcome goes out this month to Stewart MacKenzie of Huntington Beach, CA. Stewart has been the driving force behind the American Shortwave Listeners Club for over two decades. Their bulletin, *SWL*, is full of news each month about shortwave. You can write ASWLC at 16182 Ballad Lane, Huntington Beach, CA 92649 for more information. Be sure to include an SASE, and include a dollar for each sample bulletin you'd like.

4170: Single pulses of carrier, approximately 50 per minute, around 0400. Fading pattern on signal indicates possibly a European location. (Helms, NY)

5810: Four digit "numbers" message in Spanish read by woman 0240. (MacKenzie, CA)



6923: "UUU UUU UUU" repeated continuously around 0415, good signals. (Helms, NY)

7410: Five digit "numbers" message in German read by woman 0425. (Helms, NY)

7600: HD210A, Instituto Oceanografico de la Armada, Guayaquil, Ecuador, pulses each second, time announcement each minute in Spanish by man, around 0340. (Helms, NY)

7630: Five digit "numbers" message in English read by woman 0210, good signal. (Helms, NY)

7917: This one is similar to a "numbers" station, but not quite! Around 0415, message in English, read by woman, consisting of groups made up of five letters from the international phonetic alphabet, such as "alpha kilo bravo sierra tango," etc! Weak signals and fading pattern indicate probably European location. (Helms, NY)

8417: Four digit "numbers" message in Spanish read by woman, heard at same time and date as the 5810 item. (MacKenzie, CA) That's a great pair of loggings, Stew, and another clue toward solving the mystery!—Editor.

8765: NMC, U.S. Coast Guard, San Francisco, CA, weather broadcast in SSB 1630. (MacKenzie, CA)

9074: "Numbers" message in Spanish read by a man 0515. (MacKenzie, CA) Five or four digit groups? An excellent, rare catch!—Editor.

D Z G
COAST STATION
GLOBE WIRELESS LTD.
MANILA, PHILIPPINES

CONTINUOUS WATCH on 500 KC-6 MG-8 M2-12 MC-16 MC marine frequencies.
TRANSMITS on 500KCS KC-418 KC-846 KC-1200 KC-1212.4 KC simultaneously.
TRAFFIC LIGHTS-20 minutes and every hour.
PHONE BROADCASTS-0500 GMT & 1700 GMT daily, compliance DZG
WEATHER BROADCASTS-0620 GMT - 0625 GMT daily.
STORM WARNING-Broadcast upon receipt. Please alert each Station list until received.

DZG Coast Station Charges
Including Manila Delivery
Philippine Land Exit Charge
Other than Manila

PHILIPPINE REGISTRY
FOREIGN REGISTRY

☎ 016 ☎ 032 ☎ 015 ☎ 035

TORONTO, ONT. M6E 1Y8 CAN.

13344: KIS, Federal Aviation Administration, Anchorage, AK, aeronautical weather read by man at 0025 in SSB. (MacKenzie, CA)

13344: KXM70, Federal Aviation Administration, Honolulu, HI, aeronautical weather read by man at 0030 in SSB. (MacKenzie, CA)

13344: KSF70, Federal Aviation Administration, Oakland, CA, aeronautical weather read by woman at 0035 in SSB. (MacKenzie, CA) These last three loggings illustrate how several aeronautical weather stations (VOLMETs) can share the same frequency by taking turns transmitting. — Editor.

14945: VNV71, Sydney, Australia, with SSB marker "This is Sydney Radio, Australia" read by woman at 0400. (MacKenzie, CA)

That's it—see you next month!



**SONY ICF2001
SPECIAL \$199.95**

(Plus \$7.00 Postage and Handling)

- SONY ICF7600A \$129.95
- SONY ICF6500W \$189.95
- SONY ICF8600 \$369.95
- SONY ICF6800W \$529.95
- PANASONIC RF2200 \$179.95
- PANASONIC RF2600 \$199.95
- PANASONIC RF2900 \$249.95
- PANASONIC RF3100 \$269.95
- PANASONIC RF4900 \$379.95
- PANASONIC RF6300 \$479.95

**ELECTRONIC
DISCOUNTERS**

P.O.Box 70 Mountain View Dr.
Lehman, PA. 18627

We accept personal checks, cash, or money orders. COD's send \$10.00 towards purchase. Shipped by USPS First Class insured. All orders add \$7.00 Postage and Handling. ALL PRODUCTS GUARANTEED. We carry All SONY and PANASONIC PRODUCTS AT SUBSTANTIAL DISCOUNTS. Send SASE for specific quotes. Color catalogs \$1.00. TRY US!

CIRCLE 18 ON READER SERVICE CARD

May We Recommend

The American SWL Club, 16182 Ballad Lane, Huntington Beach, CA 92649. This club has been operating since 1959. It publishes an excellent 60 page monthly DX publication covering shortwave and broadcast band DX, utility stations, QSL reports, and more. The club sponsors three annual DX meetings per year held in southern California. Dues in North America are \$16 per year (includes First Class Mailing of monthly publication). Students (located in North America and 16 years old or younger) can join for \$13 per year. A sample bulletin is available from the club for \$1 (in North America).



SPEEDX, P.O. Box E, Lake Elsinore, CA 92330. This group offers several grades of membership based upon the amount of participation in the organization's publication which, coincidentally, is called *SPEEDX!* The publication runs 60 pages per month and is chock full of news and information, frequency listings, skeds, and other information on shortwave stations, including utilities. The publication even includes a technical section. The group also offers a number of excellent reference publications and DX'ing aids. Annual membership in North America is \$16 (includes First Class Mailing of publication). A sample copy of *SPEEDX* is available from the group at \$1 (to anywhere in North America).



When writing to the above, please mention that you saw it in POP' COMM!

IC-R70

The Commercial Grade Communications Receiver that everyone has been asking for..... at a price you can afford!

NEW!

The HAM SHACK

For your discount price on ICOM and other major brands call **812-422-0231**
808 N. Main • Evansville, IN 47711

MON-FRI 9AM-6PM
SAT 9AM-3PM

CIRCLE 33 ON READER SERVICE CARD

26 Channel CATV Converter & Remote Control

VHF - Midband - Superband

- Easy to Install
- Works With Any TV
- Saves Wear On TV Tuner
- Change Channels 25' Away
- 90 Day Guarantee

Mail Order SPECIAL
\$49.95 + 4.25 Shipping

Buy 2 - We Pay Shipping • C.O.D.'s - \$1.50 extra • NYS Add Tax • DEALERS WANTED

TAYCO COMMUNICATIONS
R3 - 146A Narrows Ck. Rd. - Corning N.Y. 14830 - (607) 962-7313

CIRCLE 29 ON READER SERVICE CARD



A Real DX Challenge: Tuning In "The Rock"

BY AL MUICK

This is Gibraltar . . . You're tuned to the GBC, the Gibraltar Broadcasting Corporation, on medium wave 1458 kHz and Channels E6, E11, and Channel 60 UHF television." This is the announcement you might hear if you were to tune to 1458 kHz on a cold winter's night with a good opening to Europe! The Gibraltar Broadcasting Corporation is a little-known, little-heard station situated right on Gibraltar (commonly referred to as "the Rock of Gibraltar").

I was very fortunate in being able to contact Mr. George J. Valarino, who is the General Manager of the GBC. He provided me with all of the following information.

To begin, a small history of Gibraltar might be in order. Gibraltar is a small fortified peninsula on the southern tip of the Iberian peninsula and has seen a great deal of turmoil in its long and often bloody history. It was first captured by the British in 1704, by a combined English and Dutch force under the command of Admiral Rooke. The "Rock" had also known some 400 years of occupation by the Moors from Morocco. Traces of this occupation can be seen today in the form of the Moorish Castle and remnants of old baths and pavements.

The fortifications which surround the sea-

ward side (dating from the mid 1700s) are occupied by the GBC's Radio and Television Center. It is an incongruous sight perhaps that atop these almost medieval fortress walls one can see mast radiators, short-wave and microwave antennas, but no less incongruous than the many electronic devices on top of the 1400 foot high mass of limestone which constitutes the main bulk of "the Rock."

Gibraltar has suffered numerous sieges and is presently enduring its latest, being cut off from the Spanish mainland. Against this background, it's not hard to see the importance of broadcasting for Gibraltar.

AM radio broadcasting began in 1958 and television in 1962. The former was started by the Gibraltar government and the latter was by a local-based private firm. Both services were combined in 1963 as the independent Gibraltar Broadcasting Corporation. Thomson Television acted as managing agents until late 1978 when their contract expired.

The GBC Radio carries an appreciable percentage of Spanish language programs, BBC Spanish language relays, and commercial advertising in both languages. TV is in English only and carries mainly English

advertising. Due to Gibraltar's small size—population about 25,000 with 7,000 TV sets—there is not enough advertising to make the GBC financially independent; therefore, there is a great amount of government aid. It is interesting to note that you must have a license for your radio and TV sets in Gibraltar. The current rate is 20 pounds per year for a combined license.

GBC's programs reach their neighbors on the Spanish side of the frontier and also along the northern coast of Morocco. It is particularly strong in the Spanish enclaves of Ceuta and the city of Tangier.

The GBC has two medium wave channels (medium wave is the English equivalent of AM or BCB), and they are 1458 kHz and 1089 kHz (which is not yet in use). The AM channels use a variable power of 500 watts or 2000 watts, making reception of this station a real catch for DXers! Television can be seen on E6, E11, and Channel 60 UHF. The maximum power of the main Channel 6 transmitter is about 400 watts and about five watts each for the other two.

In recent times, the radio service has been running at about 1000 watts, but the variable power as mentioned last paragraph is always possible. In 1978, GBC began limited television service in color using the European PAL system with equipment supplied by Link Electronics of England.

Radio programming is reminiscent of British local radio, with regular phone-in programs, DJ spots, BBC World Service and European relays, and BBC Transcription Service tapes and records. Programs of local interest, political affairs, and light and classical music balance the schedule in an attempt to appeal to all tastes.

GBC has recently installed an FM transmitter and is currently experimenting with it in mono, carrying the same programming on 91.3 MHz as on 1458 kHz. As soon as a stereo studio transmitter link is installed, the FM service will begin in stereo. GBC has greatly expanded and Wellington Front is now only a BCB transmitting station with two 1000 watt transmitters. These transmitters are fed into an automatic combining unit to provide 2000 watts (now using only 1000 watts) to the mast radiator. In the event of the failure of one transmitter, its companion is switched directly to the antenna. Transmitter functions are monitored by telemetry along a single pair telephone line at the broadcasting house.

The GBC currently operates from 0655 to 2300 hours GMT and varies its programming between English and Spanish. These broadcast times should give listeners on the East Coast of the U.S. an excellent chance to log the station. If you hear the GBC, please send them a reception report. Their address is The GBC, Wellington Front, Gibraltar. They verify with a QSL letter and recordings are accepted as proof of reception. Please enclose return postage. When you write, address your reports to Mr. George J. Valarino, General Manager, and tell them you read about the GBC in *Popular Communications*. Happy listening!

WASHINGTON PULSE

FCC ACTIONS AFFECTING COMMUNICATIONS

New Licensing Procedures In Cooperative Sharing In Private Land Mobile Radio Services

Rule changes adopted by the Commission concerning new licensing procedures for cooperative sharing of private land mobile stations became effective May 20, 1982. Among those changes is one that allows participants in a cooperative use arrangement to obtain licenses for their own control stations or control points, as well as for their mobile units, if they so desire and if the licensee of the shared station agrees.

This notice explains how users should apply for licenses. Neither control points nor control stations will be licensed to users without associated mobile stations.

Control Points. To apply for separate authorization of control points, the user of a shared station must submit a signed letter of request along with a copy of a statement of agreement signed by the base station licensee. The letter must specify the location of the desired control points. (Control point requirements are in Section 90.429 of FCC rules.)

Control Stations. To apply for separate licensing of control stations, the user of a shared station must submit a completed FCC Form 400 along with a copy of a statement of agreement signed by the base station licensee. Applicants who do not already have separate licenses for their mobile stations must apply for both the control and mobile stations on the same Form 400. Applicants who have separate licenses for their mobile stations should apply for modification of those licenses to add the control stations. (Rules for control stations are in Section 90.249.)

Call Signs. Call signs of separately licensed control stations will be based on their antenna height. If the antenna meets the "20-foot rule" [§90.119(a)(2)(ii) of the Rules], the station and its associated mobiles will get a mobile station call sign. If the antenna does not meet the "20-foot rule," the station and its associated mobiles will get a land station call sign. Applicants who already have licensed mobile stations will keep their call signs if they add a control point (or points) or if they add a control station antenna meeting the "20-foot rule." Applicants will get a new land station call sign if their control station antenna does not meet the "20-foot rule."

Loading Criteria For PLMRS Systems Above 470 MHz Eliminated

The Commission has eliminated the portable-to-vehicular mobile ratio in loading cri-

teria for Private Land Mobile Radio Service (PLMRS) systems operating above 470 MHz. The action was in response to a rule-making petition by the Associated Public-Safety Communications Officers, Inc. (APCO), which requested amendment of Part 90 of the rules to eliminate the 2-1 ratio of hand-carried to vehicular mobile transmitter units for frequency loading purposes on frequencies above 470 MHz.

The Commission noted that when the rules were adopted, vehicular, rather than hand-held, transmitters were the most common modes of operation. Therefore, it was anticipated that most land mobile stations would be vehicular and portables would not form a significant portion of the transmitters generating messages which would account for channel occupancy.

However, advances in technology and design have made the hand-held portable the more useful mode of originating transmission, the Commission said. In addition, to avoid unnecessary duplicative costs, the smaller systems have relied on portables.

Therefore, the Commission has adopted rules which equate hand-carried units and vehicular mobile units operating on frequencies above 470 MHz for channel loading purposes in all PLMRS systems—except radiolocation—concluding that these rules would be more reflective of actual channel usage and would benefit licensees of PLMRS systems and the public at large.

Experimental Actions

The Commission, by its Office of Science and Technology, Frequency Liaison Branch, took the following actions during the month of July 1982:

KM2XGE, Remic Corporation, Arlington, Virginia, KM2XGF, Remic Corporation, Chicago, Illinois granted CP and Licenses for new experimental research stations to operate on 33.42, 46.30, 154.295, 460.5625, and 807.9125 MHz; 153.830, 458.050, and 809.9875 MHz to determine essential operational characteristics of a fire fighters communication system under U.S. Govt. contract.

KM2XGG, Rockwell International Corp. Near Sparks, NV. Granted CP and License for experimental developmental station to operate on 46.02 and 48.01 MHz to demonstrate Meteor Burst Communications to prospective U.S. Govt. agency customers.

KM2XGH, Electronics, Missiles, And Communications, Inc. Various locations in PA near White Have and Mountaintop. Granted CP and License for a new experimental research station to operate on 60-72, 76-88, and 174-216 MHz bands for testing and research prior to export of a VHF television back-pack system.

KM2XGJ, Donald L. Hilliard, Ward, CO. Granted CP and License for a new experimental developmental station to operate on 902-902.1 MHz for research in moonbounce communications dealing with the proposed allocation of the band to the Amateur Service.

KM2XGK, Robert I. Sutherland, San Mateo, CA. Granted CP and License for a new experimental research station to operate on 902.1-902.15 MHz for research in moonbounce communications dealing with proposed allocation of the band to the Amateur Service.

KM2XGL, Kustom Electronics, Inc. Shawnee Mission and Chanute, Kansas. Granted CP and License for a new experimental developmental station to operate on various discrete frequencies between 75 and 24150 MHz to develop avionics equipment designed to be carried aboard a stationary aircraft and used to stimulate the on-band avionics equipment.

KM2XGN, Westinghouse Communication Services, Inc. Anne Arundel, MD. Granted CP and License for a new experimental research station to operate on 420-450 MHz band as required by U.S. Govt. contract.

KM2XGO, Chrysler Corp. Detroit and Chelsea, MI. Granted CP and License for a new experimental research station to operate on various discrete frequency bands for EMC studies on electronic components in automobiles.

KM2XGP, University Of Washington, in States of WA, OR, and ID. Granted CP and License for a new experimental research station to operate on discrete frequencies between 219.250 and 219.650 MHz to be used as a portable monitoring station for use in seismic detection research.

KM2XGU, Bates College, Lewiston, Maine. Granted CP and License for a new experimental research station to operate on 145.0 MHz for use in radio frequency probe in collection of scientific data.

KE2XLZ, Environmental Research And Technology, Nevilles Island Township, PA. Granted CP and License for new experimental research station to operate on 401.7040 MHz in support of hydrologic monitoring to determine correlations between surface water levels and groundwater levels and the tracking of river levels by the groundwater table on an island.

VHF Channel 5 Assigned To Puget Sound Area To Be Used Exclusively For Vessel Traffic Service Communications

The FCC has amended its rules to make VHF Channel 5, 156.25 MHz, available ex-

clusively for Vessel Traffic Service (VTS) communications in the Seattle (Puget Sound) radio protected area.

The action granted a request by the U.S. Coast Guard which said an additional VTS channel was necessary for it to better serve the increased vessel traffic in Seattle's port area. The assignment of Channel 5 represents the second channel designated for use exclusively by the VTS in this area.

The VTS was established by the Coast Guard in order to implement provisions of the "Ports and Waterways Safety Act of 1972." The service is currently operating in a number of the largest and busiest port areas in the U.S., and is designed to prevent damage to or loss of vessels, bridges, or oth-

er structures in U.S. navigable waters, and to protect these waters and associated natural resources from environmental harm resulting from such damage or loss.

New Orleans Port Radio Protected Area Enlarged

The Commission has enlarged the radio protected area for the New Orleans Vessel Traffic Services system (VTS) to include Berwick, LA.

The U.S. Coast Guard asked the Commission to enlarge the New Orleans VTS radio protected area one degree westward to meet the increased communications needs of the water transportation industry in the Berwick area. The Coast Guard has been operating a VTS facility in Berwick on Channel 13. However, traffic has increased to the point that VTS communications are interfering with bridge-to-bridge communications on Channel 13. Enlargement of the New Orleans VTS radio protected area to include Berwick will enable the Coast Guard to use Channel 11 and eliminate the interference problem. The Commission said this change would serve the public interest.

Virginia Beach Ambulance Service Denied Emergency Designation For Wheelchair/Invalid Transport Service

The Commission has affirmed a staff decision denying Virginia Beach Ambulance Service, Inc.'s request for authority to dispatch wheelchair vans and invalid transport vehicles over station WZM-628 in the Special Emergency Radio Service.

The FCC Private Radio Bureau had denied Virginia Beach's request on the grounds that wheelchair vans are not medical ambulances under the eligibility criteria of Section 90.35(a)(3) of the Commission's rules for ambulance companies.

Virginia Beach asked the Commission to review the staff decision and to waive Section 90.35(a)(3), claiming the proposed wheelchair/invalid transport service fit the Virginia Board of Health's rules governing emergency medical services. But the Commission said Virginia law expressly prohibits vehicles such as Virginia Beach's wheelchair vans and invalid transport vehicles from emergency use. It noted that the dispatching needs in question can be satisfied in an appropriate Industrial or Land Transportation Service and denied Virginia Beach's review and waiver requests.

Standards For Assignment Of 806-821 And 851-866 MHz

The Commission proposed revising its standards for assigning frequencies in the 806-821 and 851-866 MHz bands for co-channel trunked private land mobile radio systems in a specified area of Northern California. The action is in response to a request by the California Trunking Interference As-

sociation (CTIA) for amendment of Subparts M and S of the rules to stop severe co-channel interference to trunked base stations in the Sacramento and San Joaquin Valleys and the San Francisco Bay areas. This interference phenomenon, which has developed even among stations separated by considerably more than the 70 miles prescribed by FCC rules, is a result of the area's topography. It added that a co-channel assignment standard based upon a fixed mileage separation simply does not work in this Central Valley due to unusual propagation characteristics.

The Commission noted that CTIA's arguments, the fact that an exception already exists for the four very high mountain sites in Southern California and the experience of its staff in dealing with interference complaints from Northern California trunked system licensees point to a need to consider some rule revision. Therefore, it asked for comments on whether all of CTIA's proposed alternatives for eliminating this co-channel interference are feasible, as well as whether the large area that would be affected by the proposed revision is necessary and desirable. The Commission, however, would not adopt CTIA's request to impose a moratorium on license issuance, but would condition future licenses in Northern California on the outcome of this proceeding.

Noting that CTIA's proposal to increase separation distances would limit the number of systems that can exist in a given area, the Commission requested comments on the impact this enlarged protection area would cause and an evaluation of the relative merits of its co-channel re-use approach as opposed to CTIA's proposals. It also asked whether, in light of CTIA's proposal and the increased separations involved, a licensee should be limited to a single trunked system in this geographic area until it has met the established loading requirements. While it recognized that in some cases the only viable way to provide service is by using a relatively high site because of undesired shielding effects, the Commission invited comments on whether modifications could preserve the service area as adopted in Docket 18262 on co-channel re-use.

Inquiry Begun On Maritime Safety Recommendations

The FCC began an inquiry to inform the public on maritime safety telecommunications actions under consideration by the Maritime Safety Committee (MSC) and Subcommittee on Radiocommunications of the Inter-Governmental Maritime Consultative Organization, of which the United States is a member. The Subcommittee on Radiocommunications met in March, 1982 to give further consideration to the Future Global Maritime Distress and Safety System and other matters. Draft recommendations approved by the Subcommittee are forwarded to the MSC. Under the 1974 Safety of Life at Sea (SOLAS) Convention, amendments approved by the MSC come into force after a prescribed period, usually two years.

RTTY RADIOTELETYPE FREQUENCY LISTS

2000 WORLDWIDE RADIOTELETYPE STATIONS by FREQUENCY...
press, air, military, government, diplomatic, oil utilities with calls, times, plus other information 3 to 30 MHz \$12 POSTPAID

World Press Services
Frequencies & Manual
All press services,
frequencies and transmission times. BOOK with 3 LISTS. \$8 ppd.

UNIVERSAL ELECTRONICS
1280 AIDA DR. • REYNOLDSBURG, OH 43068
CIRCLE 68 ON READER SERVICE CARD

INSTALL YOUR OWN PRIVATE TVRO SYSTEM!

Here is a complete home TVRO satellite receiving system that you can install yourself. Call or write for more information and our FREE brochure detailing systems, components and accessories.

Complete 10' and 12' systems: **CALL TODAY!**

TVRO-10	\$2995	TEM Microwave Corp
TVRO-12	\$3495	

Plus freight charges. 22518 - 97th Ave No.
24 channel receiver Corcoran, MN 55374
Drake ESR-24 \$969 **612-488-8014**

CIRCLE 25 ON READER SERVICE CARD

CABLE TV CONVERTERS DESCRAMBLERS

BUY DIRECT & SAVE



36 CHANNEL
REMOTE CONTROL
CABLE CONVERTER
\$88.00

AMATEUR MICROWAVE ANTENNA

- 26 DB Gain
 - Advanced Down Converter
 - Complete-Ready to Install
- \$119.00



LINDSEY JET I WIRELESS THE ULTIMATE CABLE T.V. CONVERTER



58 CHANNEL INFRARED
REMOTE CONTROL
COMPLETELY
PROGRAMMABLE
\$169.00

Send \$1 for Complete Catalog
VISA • MASTERCARD • COD

DIRECT VIDEO SALES

P.O. BOX 1329
JEFFERSONVILLE, INDIANA 47130

CALL TOLL FREE
1-800-626-5533

CIRCLE 37 ON READER SERVICE CARD

The Future Global System is expected to become fully operational about 1990. It will replace the existing distress communications system, which relies primarily on ship-to-ship alerting, using Morse code. While retaining ship-to-ship alerting for distances up to about 100 miles, it will rely primarily on ship-to-shore distress alerting, using polar-orbiting satellites, geostationary satellites and high frequency terrestrial systems employing digital selective calling.

The Subcommittee desires to finalize safety and distress communications equipment carriage requirements at its meeting this month. Proposed requirements vary according to the area in which a vessel operates. The Subcommittee also will consider whether the minimum tonnage at which the equipment carriage requirements will apply should be 300 tons. The U.S. proposal for a 1,600 ton minimum did not receive support at the March meeting. A plan for transition to the Future Global System also is under consideration.

Other recommendations to be considered at the December meeting include performance standards for VHF dual channel watch facilities and for narrow-band direct-printing telegraph equipment, required communications operator functions, environmental conditions for shipboard earth stations recommended by the International Maritime Satellite Organization (INMARSAT) and matters relating to the 1983 World Administrative Radio Conference (WARC) on Mobile Radio.

Deadlines for filing comments and replies will be announced. Persons wishing to participate in the preparation of U.S. positions may attend meetings of the U.S. Working Group, which are open to the public.

Amateur's Station License Revoked

An FCC Administrative Law Judge has revoked the license of Henry C. Armstrong III, Sylmar, CA, for Amateur Radio Service station WA6CGI and suspended his Advanced Class Amateur operator license for wilful and malicious interference with the transmissions of other Amateur operators. Assistant Chief Judge Thomas B. Fitzpatrick, in an Initial Decision, found that Armstrong in 1980 deliberately interfered with transmissions to and from a repeater station operated by the Southern California DX Club, an organization of Amateur operators, with the intention of driving the repeater off its input frequency of 144.88 MHz and output frequency of 145.48 MHz.

Armstrong also tried to mislead the FCC with a "cover story" that he was engaging in legitimate testing in an experimental activity. The facts of the case mandate revocation and suspension, the judge said.

FCC Field Operations Bureau engineers monitored Armstrong December 9, 1980, while lengthy computer-voice-synthesized transmissions emanated from his station on 144.8863 MHz. The transmission contained Armstrong's call sign in voice and Morse code. The FCC had received numerous

complaints that Armstrong's transmissions spread over the adjacent input frequency of the repeater station and were rebroadcast on its output frequency, interfering with its use by other Amateurs.

Armstrong is an electrical engineer who has been involved in research and development of various computer applications in telecommunications. In 1977, he began development of a pseudointelligent computer program with which a person could communicate by voice in plain English. His experiments included use of radio links to communicate by voice with a computer.

Judge Fitzpatrick credited testimony that Armstrong transmitted a threat to use computer-controlled transmissions to interfere

with the repeater. Armstrong acknowledged that he transmitted frequently, normally for seven or eight hours at a time. The judge found that Armstrong ignored complaints by other Amateurs that he was causing interference and chose not to monitor the repeater output frequency. Armstrong rendered the repeater useless for days at a time, the judge said.

Judge Fitzpatrick found that Armstrong was not transmitting for a legitimate experimental purpose and was not transmitting to any other Amateur. Armstrong was conducting one-way transmissions and broadcasting, both violations of FCC rules, in addition to deliberately causing interference, the judge found.

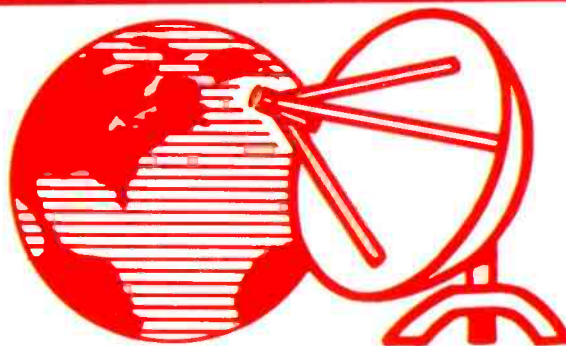

SATELLITE TELEVISION SYSTEMS

WE WILL NOT BE UNDERSOLD!!

**Complete Systems, Antennas,
Receivers, LNA's & Accessories**

CALL US TODAY!

812-238-1456

**hoosier
electronics**

"Nation's Largest Total Communications Distributor"

P.O. BOX 3300 • TERRE HAUTE, INDIANA 47803

MAILBAG

LETTERS TO THE EDITOR

The most interesting questions we receive will be answered here in each issue. Address your questions to: Tom Kneitel, Editor, Popular Communications magazine, 76 North Broadway, Hicksville, NY 11801.

Is That You, Normandy?

I would like to thank you for *POP' COMM*. It's just what I've been seeking. Especially wanted to mention that I enjoyed the October feature about all of the new, mini, artificial, odd, and future DX countries to look for on the bands. You overlooked one which old timers hereabouts recall with some pride and I would like to pass it along since it was a source of QSLs.

In January, 1937, a broadcasting station operated by Alderney Radio Ltd., was established on 6,000 kHz. Being located on Alderney Island (Channel Islands), the station was not licensed by the British General Post Office since its operators took the position that the Channel Islands are a part of the ancient Duchy of Normandy, are governed by Norman laws, and that French is the official language. The station hit the headlines in most British newspapers and they called it "the mystery station." The station broadcast for several months, created much publicity for the political claims of its owners (who were not alone in those beliefs, I might add) and was in the process of going to higher transmitter power when the Royal Court of Guernsey handed down a decision which caused the transmitting apparatus to be confiscated. A number of DXers, however, were able to obtain QSLs from a station which claimed to be located in the heretofore extinct Duchy of Normandy.

Unfortunately, all of this took place 15 years before I was born and 33 years before I owned a shortwave receiver, so I missed out on the QSL. I thought that *POP' COMM* readers might be interested in this. Best of luck and good DX! Maybe someday Alderney Radio will live again!

Henri de la Croix
Alderney, Channel Islands

Thanks, Hank. Your tidbit was not only fascinating, but also that which causes DXers to go misty eyed. A great little gem and I'm glad you told us about it. — Editor.

Radar Detector Question

I've seen lots of conflicting information regarding the legality of radar detectors. Could you offer some insights? I have one and have found it worthwhile.

Louis D'Agostino, Sr.
Austin, TX

While it's true that some localities have established various motor vehicle regulations

which seek to make the use of radar detectors unlawful, and such places have been known to give out tickets (or even confiscate the units), the fact is that you have every right to monitor any radio transmission from any source. Some localities have attempted to make their anti-detector regulations hinge on the concept that motorists aren't permitted to have in their vehicles any receivers that are capable of receiving police frequencies. However, with many police agencies monitoring CB these days, you can see that such regulations can be interpreted to the point of absurdity. Should agencies wish to push the issue, it could make CBs illegal even though they're licensed by the FCC!

Many such regulations are being challenged; quite a few have already been knocked over. Some persons have also questioned the right of the police to confiscate detector units without due process of law (Fifth Amendment to the U. S. Constitution). The fact is that since all radar systems are composed of receivers as well as transmitters, for a locality to attempt to claim that radar detectors (receivers) are illegal, they'd have to perceive the radar systems on ships and aircraft as being equally "illegal."

Of course, it's one thing to theorize about these matters and quite another to try to argue them with a police officer who insists that in his area of jurisdiction the units can't be used. In those few areas where there are local regulations that seek to prohibit radar detectors, motorists who seek to use them really have no choice but to get a good attorney and challenge the regulations in court. In the meantime, the units are quite legally manufactured and sold—and in most areas of the nation they can be used without hassle. — Editor.

Morbid Curiosity

Recently there was a program on *NBC Reports* that told of many shoppers at the Montgomery Ward store in Wheaton, MD, who claim that they were falsely accused of shoplifting and subsequently harassed and even roughed up by plainclothes store security personnel. The program said that a number of these shoppers eventually sued the store and won. Since I live near the Wheaton Mall, I'd like to know how I can monitor Montgomery Ward's security "forces" there. Sounds like they might have some interesting things to say.

P. J. O'Connell
Colesville, MD

Montgomery Ward's security personnel at that store use hand-held transceivers operating on 154.60 MHz, so you'd have to be pretty close to the mall to hear them. I saw that *NBC Reports* program too and, personally, I don't think I'd want to get sufficiently

close to the store to hear what they're saying. — Editor.

Resisting The Temptation

I notice that instruction manuals for various pieces of communications equipment usually specify lead-in cables in terms of resistance units such as "52 ohm" coaxial type, while TV receivers are always specified as requiring either "300 ohm" twin lead or "75 ohm" coaxial cable. What does this resistance designation mean? How important is it to stick with these specs? Can I use 75 ohm coaxial with my scanner? I have lots left over from a recent TV installation.

Corey Mattison
Hot Springs, AR

These are impedance rather than resistance designations, Corey. Any transmission line has a natural "surge" impedance which is governed by the inductance and capacitance per unit length of the cable. If a generator producing AC signal feeds one end of this cable, it would appear to the generator that it was "looking into" an impedance equal to the characteristic impedance of the line.

For example, consider 300 ohm twin lead. A signal generator supplying current to one end of an infinite length of this transmission line would find itself delivering current just as though it had been connected across a 300 ohm resistor. Of course, this is theoretical since it's not very likely that you'd ever find an infinitely long cable anywhere.

In practice, the usefulness of the impedance rating of transmission lines can be explained this way: if a transmission line is terminated in an impedance equal to its characteristic impedance (that is, it is properly matched to the equipment with which it is used), the load will not reflect any energy back down the line but will absorb it all. Reflected pulses result in a less than fully efficient antenna system.

In a TV receiver, such a mismatch will cause multiple images or closely spaced ghosts on the screen. In a transmitter, if the mismatch is sufficient (as measured via a VSWR bridge), TVI will result as well as RF feedback squeal in the radiated signal; it could even cause damage to the transmitter itself. In a scanner, impedance mismatch will diminish the potential coverage area you might otherwise be expected to achieve with a given antenna type and height.

Antennas designed for scanners, and the scanners themselves, are intended for optimum reception only when used with any of the several types of transmission lines rated at 52 ohms impedance. TV type 75 ohm coaxial cable may be used with a scanner in a pinch and will provide adequate reception of any strong signals. — Editor.

Beaming In

(from page 6)

him to have the information, but he didn't think you could handle it.

A column editor for a DX club bulletin told me that if a club member submits certain types of listings, he will screen "unsuitable" information, even though there isn't any actual club policy to hold back any information from its members. On the other hand, one scanner organization does have a stated policy that they will restrict from their publication any information that they don't want their members to have. I still recall seeing one of their newsletter's columns last summer, shockingly censored by means of heavy black lines drawn through some author's writings. It looked as though it had been thoroughly checked over by the KGB, CIA, FBI, and OSS!

Of course, clubs have every right to establish their own internal censorship and information restriction policies as long as they make those policies clear from the outset. Members of the club accept those restrictions when they join, while columnists for the publication understand that there's a crazed "Big Brother" somewhere in the bowels of the club waiting, black crayon in hand, to squash heretical information before it gets into the hands of its members. Very sad!

It's ironic that much of the very same information which some so vehemently attempt to restrict from reaching others is either widely known or has even been previously published elsewhere. "No," these righteous people say. "If others want to give this information out that's *their* business, but we will not do so ourselves." What courage! To their last breath they're still guarding the secret password even though it's been printed everywhere from the *National Geographic* to the *National Enquirer*. It's the kind of stiff upper lip fortitude you're sure would have made top grade officer material during the Boer War or the Boxer Rebellion.

It's just that some people sort of get their jollies by setting themselves up as censors, or at least being the arbiters of determining which information is suitable or unsuitable for their peers to possess. Or is it that they see themselves as somehow being superior to other monitors? Probably so.

The very same chap who had the information "too sensitive" to share with you also rattled on about all of the "inside contacts" he had in *this* agency, at *that* company, and which "top" monitors had entrusted to him their choicest data. He definitely perceived himself as a very heavy dude when it came to monitoring, while simultaneously brandishing actual names of persons and agencies. Although he didn't part with a single frequency listing, the sources he freely mentioned in order to impress me would have caused any of those persons to fly to Argentina if they only knew that this guy was waving them around like a flag—that is, *if* what he was saying about them was true! Ah yes,

he was the true keeper of "The Mysteries," all were expected to recognize this. Impressed? Hell yes—*was I ever!* I didn't know whether to ask him for his autograph or seek to touch the hem of his garment.

It's bad enough to see that some people are jealously guarding information that they see as being privileged (and themselves as the privileged parties), and worse to find that some would establish themselves as filters of information entrusted to them for general distribution to others. But I've even seen instances where there have been attempts to exert pressure on others to become silent. Last Spring, some guy wrote a hysterical and outrageous letter to a scanner club publication decrying some of the frequency registries I've compiled. He had a dozen far out "reasons" why he didn't like them, but the bottom line seemed obvious—he sought to prevent others from accessing themselves to the information that the registries contained.

Oh well, 1984 really isn't all that far away

anymore, and maybe George Orwell knew what he was talking about. When you see that even the federal government recently decided to "classify" previously unclassified (and published) frequency listings sitting in their computer, you sort of wonder where things are heading. Under this latest "classification" move, it would certainly seem that even Coast Guard stations guarding VHF Channel 16 for distress calls are now "classified," as are FAA control towers, and even the NOAA VHF weather broadcasts!

I think, however, that there will always be a sufficient number of real hobbyists out there in radioland who are interested in giving to and getting the most from monitoring to assure an open exchange of information for those who wish to have it. Likewise, there will always be those of us who will make every effort to see that the information is duly disseminated. That's one of the things POP'COMM is all about—and I think that's what most of our readers are all about.

COMMUNICATIONS SHOP

Advertising Rates: Non-commercial ads are 30 cents per word including abbreviations and addresses; minimum charge \$6.00 per issue. Ads from firms offering commercial products or services are \$1.00 per word; minimum charge \$20.00 per issue. Leading key words set in all caps at no additional charge. All classified ads must be prepaid in full at time of insertion; a 5% discount is offered for prepaid 6 time insertions. All ads must be typewritten double spaced.

Approval: All ad copy is subject to Publisher's approval and may be modified to eliminate references to equipment and practices which are either illegal or otherwise not within the spirit or coverage scope of the magazine.

Closing Date: The 10th day in the third month preceding date of publication. Because the advertisers and equipment contained in Communications Shop have not been investigated, the Publisher of Popular Communications cannot vouch for the merchandise listed therein. Direct all correspondence and ad copy to: PC Communications Shop, 76 N. Broadway, Hicksville, NY 11801.

WORLD'S MOST UNUSUAL Communications Books! A large selection of outstanding titles covering scanners, "confidential" frequency registries, bugging, wiretapping, electronic surveillance, covert communications, espionage, monitoring, and more! New titles being added constantly! Ask for our FREE catalog. CRB Research, Box 56-PC, Commack, NY 11725.

MICROWAVE TV ANTENNAS 2 GHz Best in the West! Complete with cable, accessories, warranty, \$125.00. Dealers wanted! Galaxy Electronics, 6007 N. 61 Ave., Glendale, AZ 85301 (602) 247-1151; MC/VISA.

POLICE CODE UNSCRABLERS, lets you hear the coded messages of Police, Fire, and Medical channels; magnetic mobile antenna and other scanner accessories; Satisfaction guaranteed: DNE Inc., Rt. 7, Box 257-B, Hot Springs, AR 71901, (501) 623-6027.

ELECTRONIC SPYING is the name of the game. It's also the title of a startling book which reveals the closely guarded methods & equipment used by professionals & amateurs who eavesdrop on homes & businesses with (sometimes) legal and (usually) illegal bugs & wiretaps. Written in non-technical language everyone can easily understand, **ELECTRONIC SPYING** has photos & illustrations clearly revealing exactly how they do it & where they get the equipment (much of it inexpensive & easily available). Leaves nothing to the imagination! Latest techniques covered & offers an in-depth wealth of information on the ever increasing electronic invasion unavailable from any other source. This book is used by law enforcement agencies as a reference manual. Only \$7.95 (plus 50¢ postage) per copy from CRB Research, P.O. Box 56, Commack, N.Y. 11725.

MILITARY COMMUNICATIONS EQUIPMENT for sale—SASE and \$1 for list with specifications to: Michael P. Murphy, 11621 Valle Vista Road, Lakeside, CA 92040.

SCANNER CRYSTALS! America's leading mail order specialist, sent to you postpaid and factory fresh! Lowest prices anywhere, so low we can't even print them here! Send for free catalog and special order form! Z-Tech, P.O. Box 70, Hauppauge, NY 11788.

SCANNER OPERATORS! Are you registered? Be assigned your own personal monitoring ID letters inscribed on beautiful 2-color bordered certificate, plus discounts and goodies! Thousands already registered! Only \$5, ppd. from CRB Research, Box 56PC, Commack, NY 11725.

POLICE ★ FIRE SCANNERS. Write for unbelievable low discount price list. Crystals \$2.94. State Police patches \$3.50. Dever Communications Discount Mail-order Service, Rt. 2, Box 277, Hot Springs, AR 71901.

HOMESAT TELEVISION HANDBOOK & BUYERS GUIDE tells everything, including programming information, advice on choosing the right system for your needs, & budget. \$10.00 H&G Homesat Services, Dept. P, Box 422, Seaford, NY 11783.

"ELECTRONIC BONANZA" Bearcat-100 \$288.49, BC-350 \$384.49, Regency D-810 \$269.95, Frequency Directories, Shortwave Receivers, Sony 2001-\$298.99, Yaesu, Panasonic, Kenwood R-600 \$344.95, R-1000 \$419.95, Great Christmas Gifts, True Discount Prices & FAST FREE UPS shipping to 48 states. Free Catalog, Galaxy Electronics, Box 1202, 67 Eber Ave., Akron, OH 44309, (216) 376-2402.

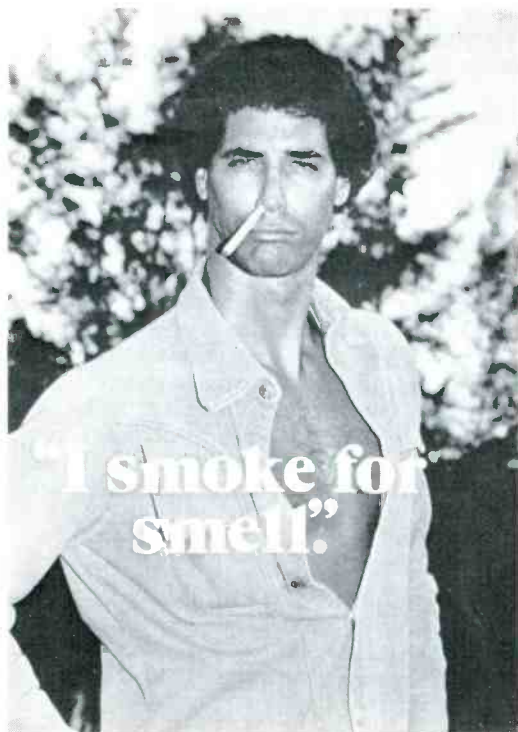

“Why Do YOU Smoke?”

Perhaps you have been lured by the billion-dollar-a-year advertising campaign of the tobacco industry.

Ask any of this year's 120,000 lung cancer victims just how sexy, sophisticated and successful smoking has made them.

“DOC” Doctors Ought To Care.

This advertisement paid for by:

DOC International
“Doctors Ought to Care”
2612 Western Avenue
Mattoon, IL 61938

AD INDEX

AEA/Adv. Elec. App.	27, 59, 71
BMW	1
Birdview Satellite Comm.	Cov. III
Capri Electronics	58
Cleveland Institute of Electronics	19
Communications Electronics	4, 12, 57
DOC	80
Digital Electronic Systems	39
Direct Video Sales	76
Electronic Discounters	73
Electronic Equipment Bank	29
Hal Communications	45
Ham Shack	73
Harvey Radio	39
Heath Co.	Cov. II
Hoosier Electronics	77
Hustler Communications	6
Japan Radio Co., Ltd.	7
KLM Electronics, Inc.	2, 3
Lewis Construction Co.	53
Long's Electronics	Cov. IV
Macrotronics	71
Madison Electronic Supply	30
MFJ Enterprises, Inc.	53
NRI	55
Panasonic	13
Pop Comm Book Shop	62
Sony Corporation	37
Tayco Comm.	73
Tem Microwave	76
Tennessee Electronics	43
Universal Electronics	76, 80
Winn-Tenna, Inc.	23
Z-Tech	23

UNIVERSAL M-600 MULTI-MODE AND CRYPTO-DECODER

— NEW —
DECODES:

TOR-SITOR
 BIT INVERSION
 WEATHER FORMAT
 NON STANDARD SHIFT



The M-600 converts these Codes plus RTTY (Baudot & ASCII) to video and will drive a Serial or Parallel printer for hard copy. Baudot speeds from 60 to 132 WPM and ASCII from 110 to 1200 Baud rates. Morse reception, auto range up to 60 WPM. The M-600 has 3 fixed shifts and 1 tunable shift. Multiple scroll inhibit and un-shift on space are included along with a built-in self-test system. Isolated loop MIL-188 or RS232 and optional parallel ASCII.

CONTACT US FOR FURTHER INFORMATION

Phone: (614) 866-4605 \$799.95
 MC & VISA Accepted (shipping extra)

UNIVERSAL ELECTRONICS INC.
 1280 AIDA DRIVE, REYNOLDSBURG, OHIO 43068

**NOW
AVAILABLE**

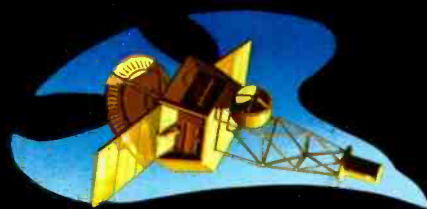

BirdviewTM

**Home Satellite
Television
Only \$2,995**
Suggested Retail
Complete System

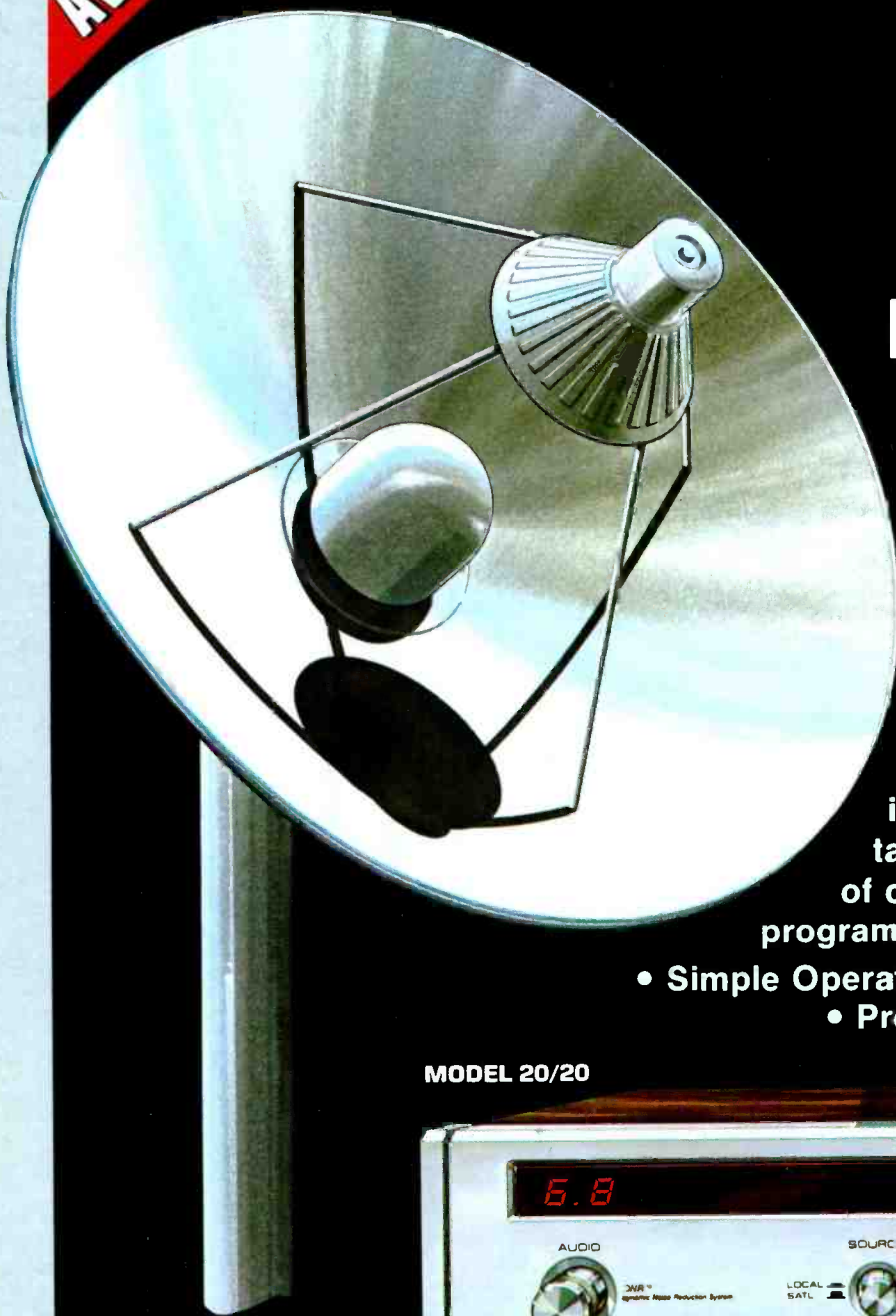

If your viewing is limited to a few TV channels — see what you're missing. Tune in sporting events, international news, movies, entertainment channels and a wide variety of children's, cultural and educational programs.

- Simple Operation
- "Live" Picture Quality
- Professional Installation

MODEL 20/20



YOU GET THE PICTURE 20/20

Turn ordinary television into extraordinary entertainment.
Call or write for the dealer nearest you.

CALL TOLL FREE: 1-800-835-0662 Kansas: 1-800-362-0088

Birdview Satellite Communications, Inc. POST OFFICE BOX 963, CHANUTE, KANSAS 66720 316-431-0400

CIRCLE 76 ON READER SERVICE CARD

When the world talks...



B.



C.

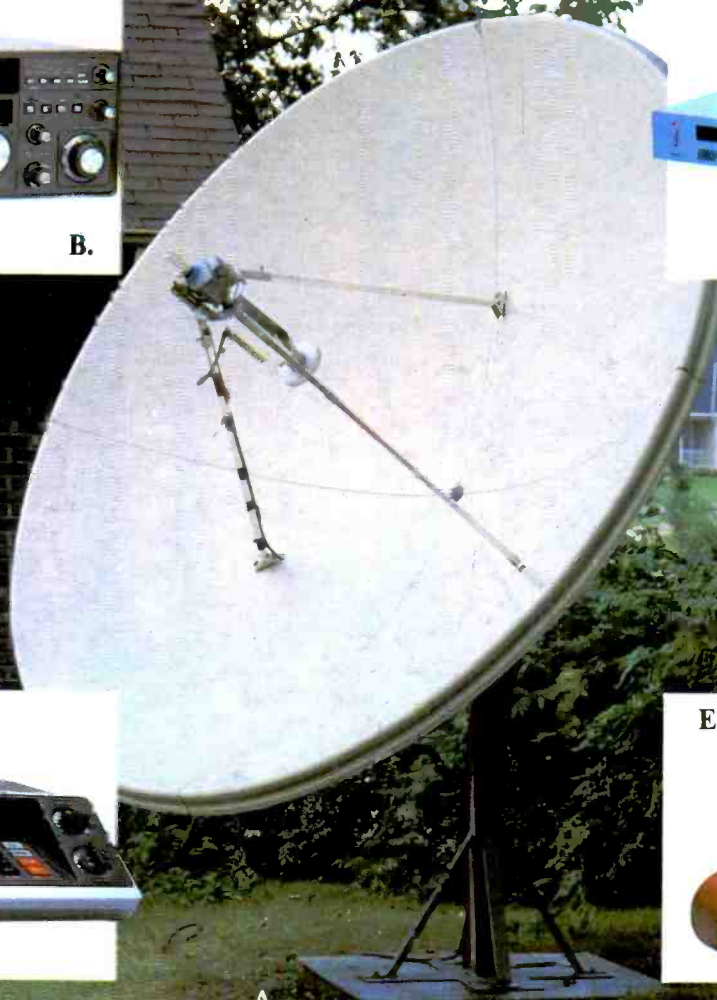

A.



D.



E.

You can listen

A. Complete satellite TV system with 10 foot parabolic dish antenna made of weather resistant fiberglass. Comes in 4 sections for easy assembly. You can receive up to 60 channels of television, direct from satellites, in your own home with this 10 foot satellite TV system . . . \$1995
B. YAESU FRG-7700. Continuous coverage (150 kHz-29.999 MHz) high performance, communications receiver. All mode operation including FM. LED frequency display, built in clock and timer. 12 memory

channels for storage of any desired frequency (optional.)
 List 549.00 494.10
C. KLM Sky Eye IV satellite receiver. Provides exceptional performance at a reasonable price. Consists of two units, downconverter and receiver. Features AGC defeat, slide rule tuning, "center tune" LED and single conversion electronics. Raw video and audio outputs. Optional RF modulator available.
 List 995.00 695.00
D. BEARCAT 210XL 18 channel

programmable scanner. Frequency coverage: 32-50 MHz, 144-174 MHz, and 420-512 MHz. Mode of operation FM. External antenna jack.
 List 349.95 229.95
E. KENWOOD TR-2500 two meter FM hand held transceiver. Frequency coverage: 144.000-147.995 MHz. BNC antenna terminal. Ten frequencies may be stored for scanning. External speaker/mic jacks. Optional base stand charger, power supply available. List 329.95 296.95
 LH-2 leather case 37.95

CALL TOLL FREE

1-800-633-6461 or 1-800-633-3410

IN ALA. 1-800-292-8668 9 AM TIL 5:30 PM CST MONDAY THRU FRIDAY

Long's Electronics



MAIL ORDERS: P.O. BOX 11347 BIRMINGHAM, AL 35202 • STREET ADDRESS: 313 1/2 4TH AVENUE SOUTH BIRMINGHAM, ALABAMA 35233

CALL OR WRITE FOR OUR FREE CATALOG

CIRCLE 32 ON READER SERVICE CARD

www.americanradiohistory.com